

ControlLogix HART Analog I/O Modules

Catalog Numbers 1756-IF8H, 1756-IF8IH, 1756-IF16H, 1756-IF16IH, 1756-OF8H, 1756-OF8IH



Important User Information

Read this document and the documents listed in the additional resources section about installation, configuration, and operation of this equipment before you install, configure, operate, or maintain this product. Users are required to familiarize themselves with installation and wiring instructions in addition to requirements of all applicable codes, laws, and standards.

Activities including installation, adjustments, putting into service, use, assembly, disassembly, and maintenance are required to be carried out by suitably trained personnel in accordance with applicable code of practice.

If this equipment is used in a manner not specified by the manufacturer, the protection provided by the equipment may be impaired.

In no event will Rockwell Automation, Inc. be responsible or liable for indirect or consequential damages resulting from the use or application of this equipment.

The examples and diagrams in this manual are included solely for illustrative purposes. Because of the many variables and requirements associated with any particular installation, Rockwell Automation, Inc. cannot assume responsibility or liability for actual use based on the examples and diagrams.

No patent liability is assumed by Rockwell Automation, Inc. with respect to use of information, circuits, equipment, or software described in this manual.

Reproduction of the contents of this manual, in whole or in part, without written permission of Rockwell Automation, Inc., is prohibited.

Throughout this manual, when necessary, we use notes to make you aware of safety considerations.



WARNING: Identifies information about practices or circumstances that can cause an explosion in a hazardous environment, which may lead to personal injury or death, property damage, or economic loss.



ATTENTION: Identifies information about practices or circumstances that can lead to personal injury or death, property damage, or economic loss. Attentions help you identify a hazard, avoid a hazard, and recognize the consequence.

IMPORTANT Identifies information that is critical for successful application and understanding of the product.

Labels may also be on or inside the equipment to provide specific precautions.



SHOCK HAZARD: Labels may be on or inside the equipment, for example, a drive or motor, to alert people that dangerous voltage may be present.



BURN HAZARD: Labels may be on or inside the equipment, for example, a drive or motor, to alert people that surfaces may reach dangerous temperatures.



ARC FLASH HAZARD: Labels may be on or inside the equipment, for example, a motor control center, to alert people to potential Arc Flash. Arc Flash will cause severe injury or death. Wear proper Personal Protective Equipment (PPE). Follow ALL Regulatory requirements for safe work practices and for Personal Protective Equipment (PPE).

	Preface	11
	Summary of Changes	11
	Additional Resources	11
	 Chapter 1	
ControlLogix HART Analog I/O Modules	Module Components	14
	Module Accessories	15
	Key the Removable Terminal Block/Interface Module	16
	HART Communication	17
	Integrated HART Networks	18
	HART-enabled I/O Modules	18
	Asset Management Software	19
	Timestamping	19
	Module Scaling	19
	Electronic Keying	20
	More Information	20
	 Chapter 2	
ControlLogix Module Operation	Direct Connections	22
	Input Module Operation	22
	Input Modules in a Local Chassis	23
	Real Time Sample (RTS)	23
	Requested Packet Interval (RPI)	24
	Trigger Event Tasks	25
	Input Modules in a Remote Chassis	26
	Remote Input Modules Connected Via ControlNet Network	26
	Remote Input Modules Connected Via EtherNet/IP Network	27
	Output Module Operation	28
	Output Modules in a Local Chassis	28
	Output Modules in a Remote Chassis	29
	Remote Output Modules Connected Via ControlNet Network	29
	Remote Output Modules Connected Via EtherNet/IP Network	30
	Listen-only Mode	30
	Multiple Owners of Input Modules	31
	Configuration Changes in an Input Module with Multiple Owners	32
Unicast Communication	32	

	Chapter 3	
1756-IF8H HART Analog Input Module	Module Features	33
	Data Formats	34
	Input Ranges	34
	Module Filter	35
	Real-time Sampling	36
	Underrange and Overrange Detection.....	36
	Digital Filter	37
	Process Alarms	38
	Rate Alarm.....	39
	Wire-off Detection	39
	Wire the Module.....	40
	Circuit Diagrams.....	42
	1756-IF8H Module Fault and Status Reporting.....	43
	1756-IF8H Fault Reporting.....	44
	1756-IF8H Module Fault Word Bits.....	45
	1756-IF8H Channel Fault Tags	45
	1756-IF8H Channel Status Tags.....	46
	1756-IF8H Tag Definitions.....	46
	Configuration.....	47
	Analog Only	48
	Analog and HART PV.....	49
	Analog and HART by Channel.....	51
	Chapter 4	
1756-IF8IH HART Isolated Analog Input Module	Module Features	53
	HART Compatibility.....	54
	HART Handheld Configurator	54
	Data Formats	55
	Input Ranges	55
	Module Filter	56
	Digital Filter	57
	Real-time Sampling	58
	Underrange and Overrange Detection.....	58
	Open Circuit Detection.....	58
	Auto-Configure HART Device.....	59
	Rate Alarm.....	59
	Process Alarms	60
	Wire the Module.....	61
	Circuit Diagram	61
	1756-IF8IH Module Fault and Status Reporting.....	62
	1756-IF8IH Module Fault Word Bits.....	63
	1756-IF8IH Channel Fault Tags.....	63
	Module Calibration	64
	Module Calibration Via Logix Designer Application	64
	Module Calibration Via Output Word.....	64

Module-defined Data Types, 1756-IF8IH Module 65

- Configuration - Configure HART Device = No 65
- Configuration - Configure HART Device = Yes 66
- Input - Analog Only 67
- Input - Analog and HART PV 68
- Input - Analog and HART by Channel,
Configure HART Device = No 70
- Input - Analog and HART by Channel,
Configure HART Device = Yes 72
- Output - Analog and HART by Channel,
Configure HART Device = Yes 74

Chapter 5

1756-IF16H HART Analog Input Module

Module Features 75

- Data Formats 76
- Input Ranges 76
- Module Filter 77
- Real-time Sampling (RTS) 78
- Underrange and Overrange Detection 78
- Digital Filter 79
- Wire-off Detection 80

Wire the Module 80

Circuit Diagram 82

1756-IF16H Module Fault and Status Reporting 83

- 1756-IF16H Module Fault Reporting 84
- 1756-IF16H Module Fault Word Bits 85
- 1756-IF16H Channel Fault Tags 85
- 1756-IF16H Channel Status Tags 85

Module-defined Data Types, 1756-IF16H Module 86

- Configuration 86
- Analog Only 87
- Analog and HART PV 88
- Analog and HART by Channel 89

Chapter 6

1756-IF16IH HART Analog Input Module

Module Features 91

- HART Compatibility 92
- HART Handheld Configurator 92
- Data Formats 93
- Input Ranges 93
- Module Filter 93
- Digital Filter 95
- Real-time Sampling 96
- Underrange and Overrange Detection 96
- Open Circuit Detection 96

Wire the Module 97

Circuit Diagram 98

1756-IF16IH Module Fault and Status Reporting 99

 1756-IF16IH Module Fault Word Bits..... 100

 1756-IF16IH Channel Fault Tags 100

 1756-IF16IH Channel Status Tags..... 101

Module Calibration 101

Module-defined Data Types, 1756-IF16IH Module..... 101

 Configuration..... 102

 Analog Only 103

 Analog and HART PV..... 104

 Analog and HART PV by Channel Grouped 105

Chapter 7

1756-OF8H HART Analog Output Module

Module Features 107

 Data Formats 108

 Resolution 108

 Ramping/Rate Limiting..... 109

 Hold for Initialization 109

 Open Wire Detection..... 110

 Clamping and Limiting 110

 Clamp and Limit Alarms..... 110

 Data Echo 111

Wire the Module..... 111

Use Module Block and Output Circuit Diagrams 112

1756-OF8H Module Fault and Status Reporting 113

1756-OF8H Fault Reporting..... 114

 Module Fault Word Bits 115

 Channel Fault Word Bits 115

 Channel Status Tags 116

Module-defined Data Types, 1756-OF8H Module..... 117

 Configuration..... 117

 Analog Only 118

 Analog and HART PV..... 119

 Analog and HART by Channel..... 121

 Output 122

Chapter 8

1756-OF8IH HART Analog Output Module

Module Features 123

 Data Formats 124

 Powerup State..... 125

 Fault Mode Output State 125

 Ramping (Rate Limiting) 125

 Hold for Initialization 126

 Open Wire Detection..... 126

 Clamping (Limiting) 126

 Clamp and Limit Alarms..... 127

Data Echo	127
HART Device Auto-configuration.....	127
Write HART Variables	127
Wire the Module.....	128
Output Circuit Diagram.....	128
1756-OF8IH Module Fault and Status Reporting.....	129
1756-OF8IH Module Fault Reporting.....	130
Module Fault Word Bits	131
Channel Fault Word Bits	131
Channel Status Tags.....	132
Module Calibration	133
Module Calibration Via Logix Designer Application	133
Module Calibration Via Output Word.....	133
Module-defined Data Types, 1756-OF8IH Module.....	134
1756-OF8IH Configuration, Configure HART Device = No.....	134
1756-OF8IH Configuration, Configure HART Device = Yes	136
1756-OF8IH Input - Analog Only.....	137
1756-OF8IH Input - Analog and HART PV	138
Analog and HART by Channel, Configure HART Device = No.....	139
Analog and HART by Channel, Configure HART Device = Yes	141
Output, Configure HART Device = No	143
Output, Configure HART Device = Yes	143

Chapter 9

Configure Modules in the Logix Designer Application

Create a New Module	145
General Tab	147
HART Configuration	148
Connection Tab	149
Module Info Tab.....	149
Status.....	150
Coordinated System Time (CST).....	150
Refresh or Reset Module	150
Apply Changes.....	151
Configuration Tab - Input Modules	151
Configure Individual Channels	152
Scaling to Engineering Units	153
Configure All Channels.....	156
Module Resolution	157
Alarm Tab - 1756-IF8H and 1756-IF8IH Modules	158
Configuration Tab - Output Module	160
Configure Individual Channels	160
Configure All Channels.....	161

Output State Tab - Output Module 162
 Ramp Rate 162
 Output State in Program Mode 163
 Output State in Fault Mode 163
 Communication Failure 163
 Limits Tab - 1756-OF8H and 1756-OF8IH Modules 164
 HART Device Info Tab 165
 Set Device Info (1756-IF8IH and 1756-OF8IH Modules) ... 168
 HART Command Tab -
 1756-IF8IH, 1756-OF8IH 169
 Calibration Tab 170
 Data in the Input Tags 170
 HART Dynamic Variables 171
 How the Module Automatically Collects Data 174

Chapter 10

Use a CIP MSG to get HART Data

Use MSG Instructions to Access the HART Object 178
 CIP Services to Access Common HART Data 179
 Read Dynamic Variables (Service Code = 16#4B) 179
 Read Additional Status (Service Code = 16#4C) 181
 Get Device Information (Service Code 16#4D) 182
 Use a CIP Generic MSG to get HART Device Information 184
 CIP Services to Pass-through a HART Message to the
 HART Field Device 187
 HART Module Scanning Diagram with Pass-through Messages .. 189
 HART Pass-through CIP Message Layout Details 191
 Pass-through Init (Service Code 16#4E) 191
 Pass-through Query (Service Code 16#4F) 192
 Flush Queue (Service Code= 16#50) 193
 HART Pass-through Message Ladder Logic Example 194

Chapter 11

HART Modules Used with Asset Management Software

Considerations for Asset Management Systems 199
 Frequently Asked Questions 200

Chapter 12

Use Ladder Logic to Unlatch Alarms and Reconfigure Modules

Using Message Instructions 203
 Processing Real-time Control and Module Services 204
 One Service Performed Per Instruction 204
 Creating a New Tag 204
 Enter Message Configuration 206
 Unlatch Alarms in the 1756-IF8H or 1756-IF8IH Module 209
 Unlatch Alarms in the 1756-OF8H or 1756-OF8IH Module ... 211
 Reconfigure a Module 213

	Chapter 13	
Troubleshoot the Module	Use Module Indicators	215
	General Troubleshooting Tips	216
	Use the Logix Designer Application to Troubleshoot a Module ..	220
	Module Configuration Errors	221
	Additional Fault Codes - Module Level.....	221
	Additional Fault Codes - Channel Level.....	222
	Remove the Module.....	224
	Appendix A	
Use 1492 Wiring Systems with Your Analog I/O Module	Wiring System Uses	225
	Appendix B	
Additional HART Protocol Information	Message Structure	228
	Master-slave Operation	228
	Multiple Master Operation.....	228
	Transaction Procedure.....	228
	Burst Mode	229
	Response Code and Field Device Status	229
	HART PV, SV, TV, and FV Status	236
	Appendix C	
Manufacturer Identification Codes	239
	Appendix D	
Engineering Unit Code Numbers	Code Number Details	247
	Glossary	253
	Index	257

Notes:

This manual describes how to install, configure, and troubleshoot ControlLogix® HART (Highway Addressable Remote Transducer) analog I/O modules.

We assume that you can program and operate an Allen-Bradley® ControlLogix programmable automation controller. If you cannot, see the Logix5000™ controller documentation listed under Additional Resources before attempting to use these modules.

Summary of Changes

This manual contains new and updated information as indicated in the following table.

Topic	Page
Added information for 1756-IF16IH module	Throughout
Updated Electronic Keying section	20
Added chapter for 1756-IF16IH module	91
Removed installation chapter. For installation information, see the ControlLogix HART Analog I/O Modules Product Information, publication 1756-PC017 .	

Additional Resources

These documents contain additional information concerning related products from Rockwell Automation.

Resource	Description
1756 ControlLogix I/O Modules Specifications Technical Data, publication 1756-TD002	Provides specifications for ControlLogix I/O modules, including the HART analog I/O modules.
Bulletin 1492 Digital/Analog Programmable Controller Wiring Systems Technical Data, publication 1492-TD008	Provides information for the AIFMs and pre-wired cables that can be used with the 1756-IF8H, 1756-IF8IH, 1756-IF16H, 1756-IF16IH, 1756-OF8H, and 1756-OF8IH modules.
ControlLogix HART Analog I/O Modules Release Notes, publication 1756-RN636	Contains release information about the ControlLogix 1756-IF8H and 1756-OF8H analog modules with HART protocol.
ControlLogix System User Manual, publication 1756-UM001	Provides configuration and operational procedures for ControlLogix controllers.
Electronic Keying in Logix5000 Control Systems Application Technique, publication LOGIX-AT001	Provides information on Electronic Keying in Logix5000 control systems.
Logix5000 Controllers Common Procedures Programming Manual, publication 1756-PM001	Provides access to a collection of programming manuals that describe procedures that are common to all Logix5000 controller projects.
Allen-Bradley Industrial Automation Glossary, publication AG-7.1	Defines terms that are not listed in the Glossary of this user manual.
Industrial Automation Wiring and Grounding Guidelines, publication 1770-4.1	Provides general guidelines for installing a Rockwell Automation industrial system.
Product Certifications website, http://www.rockwellautomation.com/certification/overview.page	Provides declarations of conformity, certificates, and other certification details.

You can view or download publications at <http://www.rockwellautomation.com/global/literature-library/overview.page>. To order paper copies of technical documentation, contact your local Allen-Bradley distributor or Rockwell Automation sales representative.

Notes:

ControlLogix HART Analog I/O Modules

This chapter discusses these topics.

Topic	Page
Module Components	14
Module Accessories	15
Key the Removable Terminal Block/Interface Module	16
HART Communication	17
Asset Management Software	19
Timestamping	19
Module Scaling	19
Electronic Keying	20

ControlLogix® HART analog I/O modules connect a Logix controller to your process. HART input modules (1756-IF8H, 1756-IF8IH, 1756-IF16H, and 1756-IF16IH) receive signals from process value transmitters and convert them to corresponding measurement values for use in the Logix controller (for example, temperature, flow, pressure, or pH). HART output modules (1756-OF8H, 1756-OF8IH) provide current or voltage output signals that adjust the settings of valves and other devices in accord with desired process behavior.

Instruments that support the HART protocol allow several process parameters to be measured with one field device, provide status and diagnostics information, and allow remote configuration and troubleshooting.

TIP ControlLogix HART analog I/O modules are also available with conformal coating.

Module Components

This figure shows physical features of ControlLogix analog I/O modules.

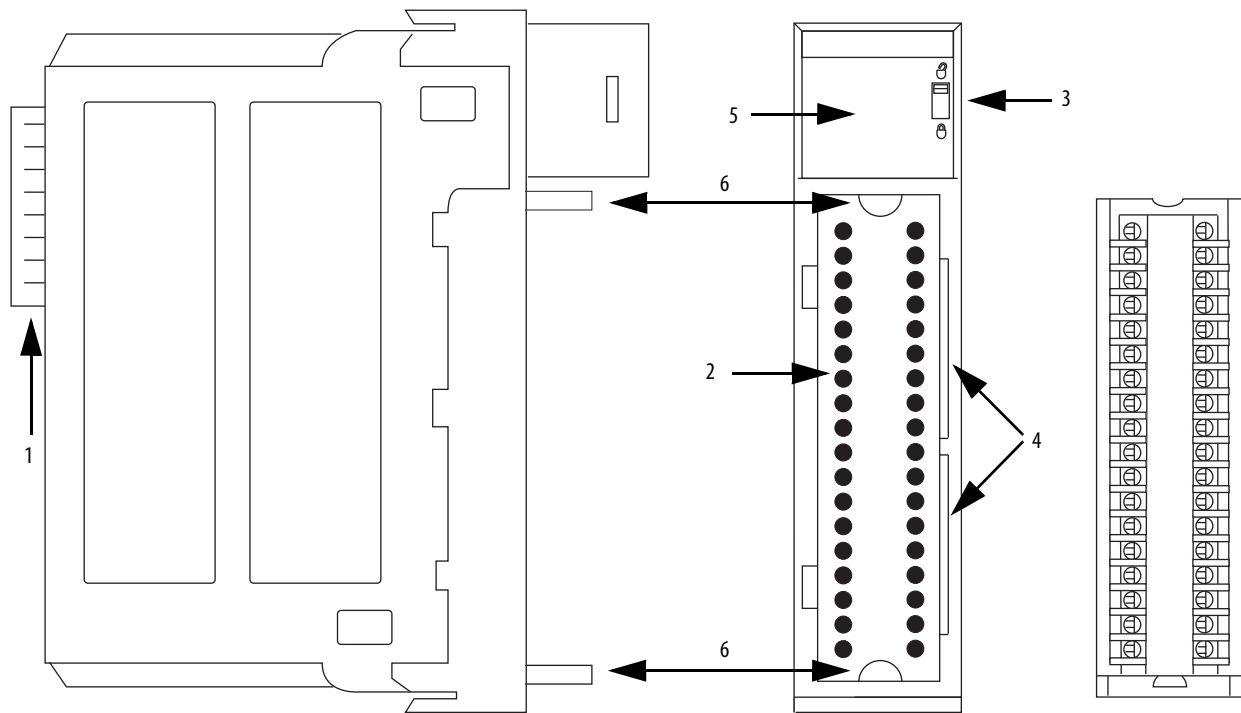

Item	Description
1	Backplane connector - Connects the module to the ControlBus™ backplane.
2	Connector pins - Input/output, power, and ground connections are made through these pins with the use of an RTB (removable terminal block) or IFM (interface module).
3	Locking tab - Anchors the RTB or IFM cable on the module, which helps to maintain wire connections.
4	Slots for keying - Mechanically key the RTB to prevent inadvertently making the wrong wire connections to the module.
5	Status indicators - Display the status of communication, module health, and input and output devices. Use these indicators to help in troubleshooting.
6	Top and bottom guides - Help to seat the RTB or IFM cable onto the module.

Module Accessories

These modules mount in a ControlLogix chassis and use a separately ordered removable terminal block (RTB) or 1492 analog interface module (AIFM) to connect all field-side wiring.

The ControlLogix HART analog I/O modules use one of the following RTBs and support these AIFMs.

Module	RTBs ⁽¹⁾	AIFMs ⁽²⁾
1756-IF8H	<ul style="list-style-type: none"> 1756-TBCH 36-position cage clamp RTB 1756-TBS6H 36-position spring clamp RTB 	<ul style="list-style-type: none"> 1492-AIFM8-3 (current and voltage) 1492-AIFM8-F-5 (current and voltage)
1756-IF8IH	<ul style="list-style-type: none"> 1756-TBCH 36-position cage clamp RTB 1756-TBS6H 36-position spring clamp RTB 	<ul style="list-style-type: none"> 1492-AIFM8-3 (current and voltage) 1492-AIFM8-F-5 (current and voltage) 1492-RAIFM8-3 (current and voltage)
1756-IF16H	<ul style="list-style-type: none"> 1756-TBCH 36-position cage clamp RTB 1756-TBS6H 36-position spring clamp RTB 	1492-AIFM16-F-3 (current and voltage)
1756-IF16IH	<ul style="list-style-type: none"> 1756-TBCH 36-position cage clamp RTB 1756-TBS6H 36-position spring clamp RTB 	
1756-OF8H	<ul style="list-style-type: none"> 1756-TBNH 20-position NEMA RTB 1756-TBSH 20-position spring clamp RTB 	<ul style="list-style-type: none"> 1492-AIFM8-3 (current and voltage) 1492-RAIFM8-3 (current and voltage)
1756-OF8IH	<ul style="list-style-type: none"> 1756-TBCH 36-position cage clamp RTB 1756-TBS6H 36-position spring clamp RTB 	

(1) Use an extended-depth cover (1756-TBE) for applications with heavy gauge wiring or requiring additional routing space.

(2) See the AIFMs for the respective modules on [page 226](#). Consult the documentation that came with it to connect all wiring.



ATTENTION: The ControlLogix system has been agency certified with only the ControlLogix RTBs (catalog numbers 1756-TBCH, 1756-TBS6H, 1756-TBNH, 1756-TBSH). Any application that requires agency certification of the ControlLogix system with other wiring termination methods can require application-specific approval by the certifying agency.

Key the Removable Terminal Block/Interface Module

Wedge-shaped keying tabs and U-shaped keying bands come with your RTB to help prevent connecting the wrong wires to your module. Key the positions on the module that correspond to unkeyed positions on the RTB. For example, if you key the first position on the module, leave the first position on the RTB unkeyed.

1. To key the module, insert the U-shaped band and push the band until it snaps into place.

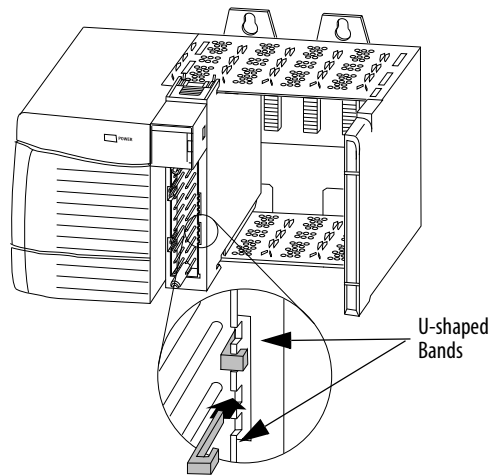

20850

2. To key the RTB/IFM, insert the wedge-shaped tab with the rounded edge first and push the tab until it stops.

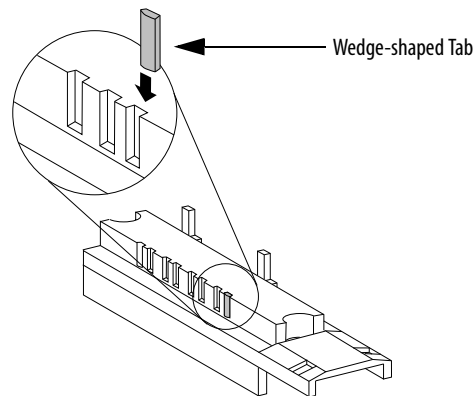

20851

You can reposition the tabs to re-key future module applications.

HART Communication

The HART field communication protocol is widely accepted in industry as a standard for digitally enhanced 4...20 mA communication with smart (microprocessor-based) field devices. A digital signal is superimposed on the 4...20 mA current loop to provide two means of communication from the device. The 4...20 mA analog channel lets the primary process variable be communicated at the fastest possible rate while the digital channel communicates multiple process variables, data quality, and device status. The HART protocol lets these simultaneous communication channels be used in a complementary fashion.

The ControlLogix HART analog I/O modules support the HART protocol and perform these operations:

- Conversion of 4...20 mA analog signals to digital numeric values in engineering units (such as kg, m, or percent) that are used in the Logix controller.
- Conversion of digital numeric values in engineering units to 4...20 mA analog signals to control process devices.
- Automatic collection of dynamic process data from the connected HART field device (for example, temperature, pressure, flow, or valve position).
- Facilitation of configuration and troubleshooting of the HART field device from your control room with FactoryTalk® AssetCentre service.

This figure⁽¹⁾ shows information about the HART protocol.

The Highway Addressable Remote Transducer (HART) protocol supports two-way digital communication, complements traditional 4...20 mA analog signals, and includes the following features:

- Predefined commands
 - Common practice
 - General purpose
 - Device specific
- Large installed base
- Worldwide support

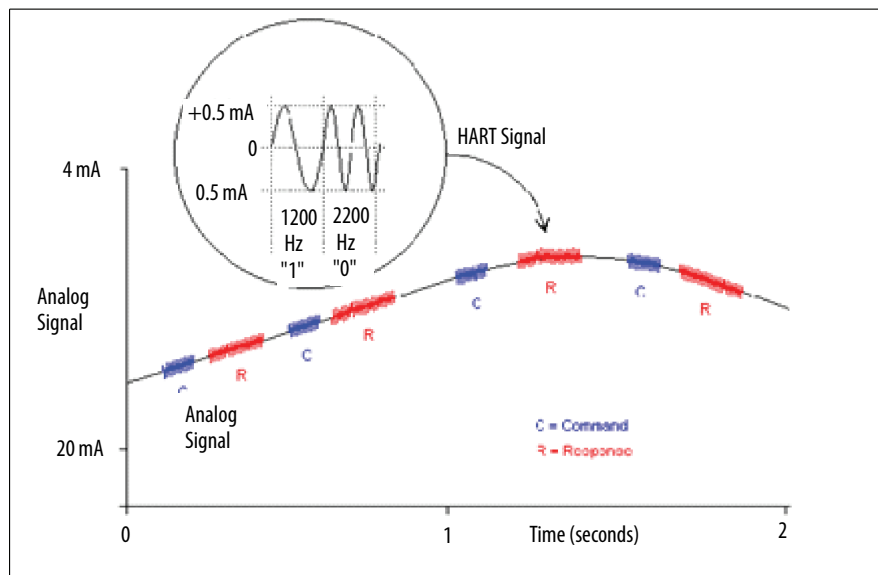

With the ControlLogix HART analog I/O modules, both the controller and software for device maintenance and management can access field device data.

The ControlLogix HART analog I/O modules support command-response communication protocol and point-to-point wiring architecture.

(1) The figure is from the HART Communication Protocol Specifications, April 2001, Revision 6.0, HART Communication Foundation, All Rights Reserved.

The ControlLogix HART analog I/O modules can accept commands from either of two master devices. The controller is one of the master devices and continuously obtains information from the field device. The second master can be used for device maintenance, for example a handheld communicator, as shown here.

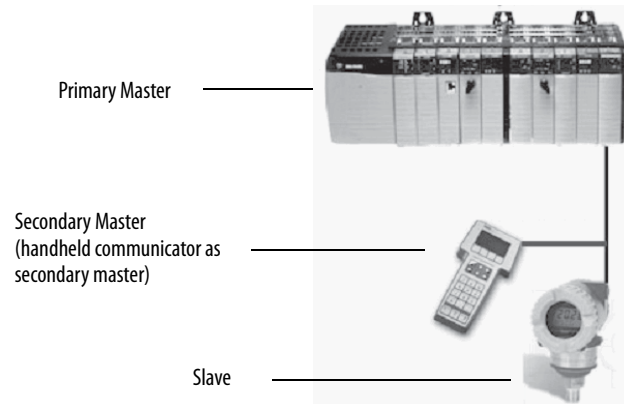

Integrated HART Networks

Most 4...20 mA transmitters are available with a HART protocol interface. The type of data available depends on the type of instrument.

An example application is a HART enabled mass flowmeter. The standard mA signal from the flowmeter provides one primary measurement - flow. The mA signal with HART provides more process information. The mA signal that represents flow is still available. The HART configuration of the flowmeter can be set to communicate [primary value \(PV\)](#), [secondary value \(SV\)](#), [third value \(TV\)](#), and [fourth value \(FV\)](#). These values can represent mass flow, static pressure, temperature, total flow, and other conditions.

Device status information is also provided via HART. Instead of one process variable, with HART the controller sees four process variables, has a check on the mA signal, and has a reading of device status. HART connectivity provides all this information with no changes to the existing 4...20 mA wiring.

FDT/DTM technology via HART connectivity also provides remote configuration and troubleshooting of field devices by using software such as FactoryTalk AssetCentre or Endress+Hauser FieldCare software.

HART-enabled I/O Modules

The ControlLogix HART analog I/O modules have built-in HART modems, so there is no need to install external HART multiplexers or clip-on HART modems. The 1756-IF8H and 1756-OF8H modules have one HART modem per module. The 1756-IF8IH, 1756-IF16H, 1756-IF16IH, and 1756-OF8IH modules have a separate HART modem for each channel.

Asset Management Software

You can use the HART analog I/O modules with asset management software, such as FactoryTalk AssetCentre software or Endress+Hauser FieldCare software, as shown in this figure.

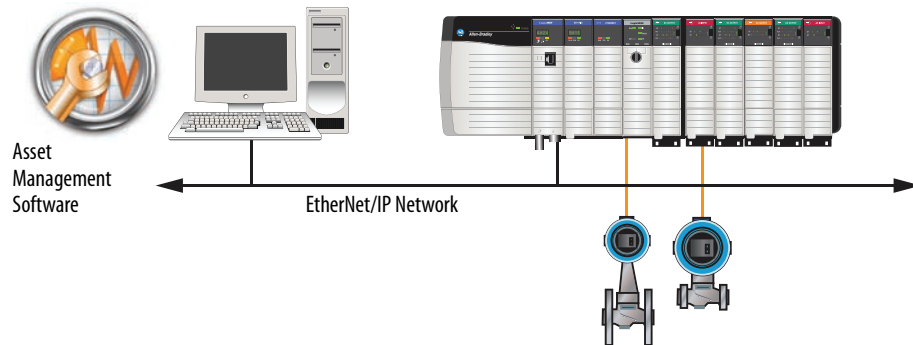

Timestamping

Controllers in the ControlLogix chassis maintain a system clock. This clock is also known as the coordinated system time (CST). You can configure your analog I/O modules to access this clock and time stamp input data or output echo data when the module multicasts to the system.

This feature provides accurate calculations of time between events to help you identify the sequence of events in fault conditions or in the course of normal I/O operation. The system clock can be used for multiple modules in the same chassis.

Each module maintains a rolling time stamp that is unrelated to the coordinated system time. The rolling time stamp is a continuously running 15-bit timer that counts in milliseconds.

When an input module scans its channels, it also records the value of the rolling time stamp. Your program can use the last two rolling time stamp values to calculate the interval between receipt of data or the time when new data was received.

For output modules, the rolling time stamp value is updated only when new values are applied to the Digital to Analog Converter (DAC).

Module Scaling

Use module scaling to specify the range of engineering units that corresponds to the analog input or output signal of a module. Choose two points along the module operating range and specify corresponding low and high engineering unit values for those points.

Scaling lets you configure the module to return data to the controller in units that match the quantity being measured. For example, an analog input module can report temperature in degrees Celsius or pressure in mbar. An analog output module can receive commands in % of stroke of a valve. Scaling makes it easier to use the values in your control program instead of using the raw signal value in mA.

For more information about scaling, see [Scaling to Engineering Units on page 153](#).

Electronic Keying

Electronic Keying reduces the possibility that you use the wrong device in a control system. It compares the device that is defined in your project to the installed device. If keying fails, a fault occurs.

Table 1 - Attributes Compared During Electronic Keying

Attribute	Description
Vendor	The device manufacturer.
Device Type	The general type of the product, for example, digital I/O module.
Product Code	The specific type of the product. The Product Code maps to a catalog number.
Major Revision	A number that represents the functional capabilities of a device.
Minor Revision	A number that represents behavior changes in the device.

Table 2 - Available Electronic Keying Options

Keying Option	Description
Compatible Module	Lets the installed device accept the key of the device that is defined in the project when the installed device can emulate the defined device. With Compatible Module, you can typically replace a device with another device that has the following characteristics: <ul style="list-style-type: none"> • Same catalog number • Same or higher Major Revision • Minor Revision as follows: <ul style="list-style-type: none"> – If the Major Revision is the same, the Minor Revision must be the same or higher. – If the Major Revision is higher, the Minor Revision can be any number.
Disable Keying	Indicates that the keying attributes are not considered when attempting to communicate with a device. With Disable Keying, communication can occur with a device other than the type specified in the project. ATTENTION: Be extremely cautious when using Disable Keying; if used incorrectly, this option can lead to personal injury or death, property damage, or economic loss. We strongly recommend that you do not use Disable Keying. If you use Disable Keying, you must take full responsibility for understanding whether the device being used can fulfill the functional requirements of the application.
Exact Match	Indicates that all keying attributes must match to establish communication. If any attribute does not match precisely, communication with the device does not occur.

Carefully consider the implications of each keying option when selecting one.

IMPORTANT Changing Electronic Keying parameters online interrupts connections to the device and any devices that are connected through the device. Connections from other controllers can also be broken.
If an I/O connection to a device is interrupted, the result can be a loss of data.

More Information

For more detailed information on Electronic Keying, see Electronic Keying in Logix5000™ Control Systems Application Technique, publication [LOGIX-AT001](#).

ControlLogix Module Operation

This chapter discusses these topics.

Topic	Page
Direct Connections	22
Input Module Operation	22
Input Modules in a Local Chassis	23
Input Modules in a Remote Chassis	26
Output Module Operation	28
Output Modules in a Local Chassis	28
Output Modules in a Remote Chassis	29
Listen-only Mode	30
Multiple Owners of Input Modules	31
Configuration Changes in an Input Module with Multiple Owners	32
Unicast Communication	32

A ControlLogix® controller must own every I/O module in the ControlLogix system. The owner controller stores configuration data for every module that it owns. The owner controller can be located locally (in the same chassis) or remotely (in another chassis), relative to the position of the I/O module. The owner controller sends configuration data to the I/O module to define the behavior of the module and begin operation within the control system. Each ControlLogix I/O module must continuously maintain communication with its owner to operate normally.

Typically, each module in the system has only one owner. Input modules can have multiple owners. Output modules are limited to one owner.

With the Producer/Consumer model, ControlLogix I/O modules can produce data without a controller polling them first. The modules produce the data and any owner or listen-only controller device can consume it.

For example, an input module produces data and any number of controllers can consume the data simultaneously. This feature minimizes the need for one controller to send data to another controller.

Direct Connections

A direct connection is a real-time data transfer link between the controller and the device that occupies the slot that the configuration data references. ControlLogix analog I/O modules use direct connections only.

When an owner controller downloads module configuration data, the controller attempts to establish a direct connection to each of the modules the data references.

If a controller has configuration data that references a slot in the control system, the controller periodically checks for the presence of a module there. When presence of a module is first detected, the controller automatically sends the configuration data and one of the following events occurs:

- If the data is appropriate to the module found in the slot, a connection is made and operation begins.
- If the configuration data is not appropriate, the module rejects the data and an error code displays in the software. For example, configuration data for a module can be appropriate except for a mismatch in electronic keying that prevents normal operation. For more information about error codes, see [Module Configuration Errors on page 221](#).

The controller maintains and monitors its connection with a module. Any break in the connection (for example, module removal under power) causes the controller to set fault status bits in the data area that is associated with the module. You can use ladder logic to monitor this data area and detect module failures.

Input Module Operation

In the ControlLogix system, the owner controller does not poll analog input modules after a connection is established. The modules multicast their data periodically. Multicast frequency depends on options that are chosen during configuration and the physical location of the module in the control system.

Communication or multicasting behavior of a module varies depending upon whether the module operates in a local or remote chassis (relative to the owner controller), based on network type. The following sections detail the differences in data transfers between these setups.

Input Modules in a Local Chassis

When a module resides in the same chassis as the owner controller, the following configuration parameters affect how and when the input module multicasts data:

- Real-time sample (RTS)
- Requested packet interval (RPI)

Real Time Sample (RTS)

This configurable parameter instructs the module to perform the following operations:

- Scan all of its input channels and store the data into onboard memory
- Multicast the updated channel data (and other status data) to the backplane of the local chassis

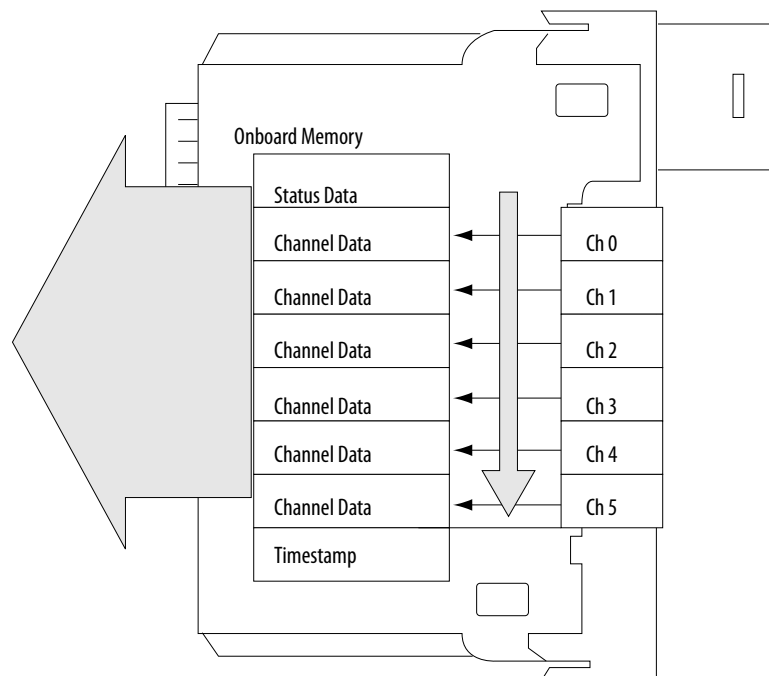

IMPORTANT The real-time sample value is set during the initial configuration with the Studio 5000 Logix Designer® application. This value can be adjusted at any time.

Requested Packet Interval (RPI)

The requested packet interval instructs the module to multicast its channel and status data to the local chassis backplane.

This configurable parameter also instructs the module to multicast the **current contents** of its onboard memory when the requested packet interval expires. (The module does not update its channels before the multicast.)

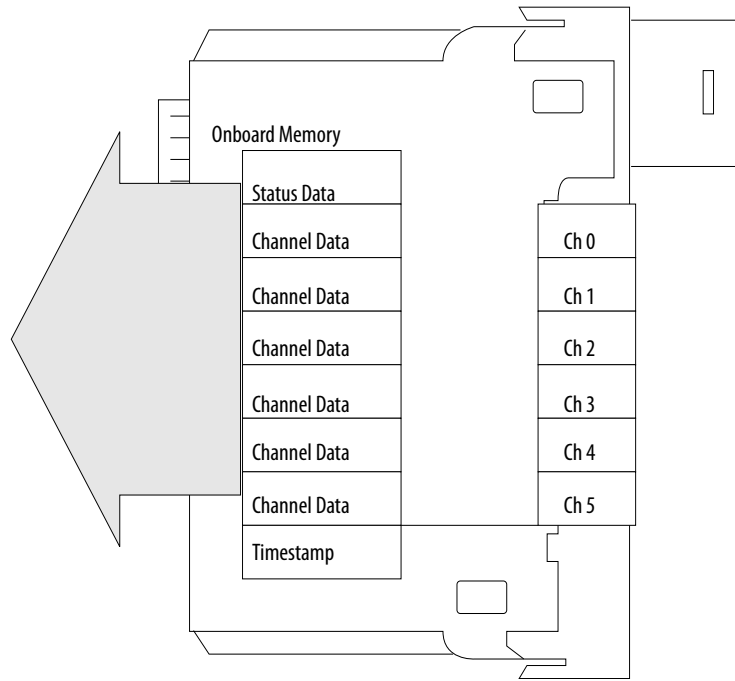

IMPORTANT The requested packet interval value is set during the initial module configuration with the Studio 5000 Logix Designer® application. This value can be adjusted when the controller is in Program mode.

If the real-time sample value is less than or equal to the requested packet interval, each multicast of data from the module has updated channel information. In effect, the module is only multicasting at the real-time sample rate.

If the real-time sample value is greater than the requested packet interval, the module multicasts at both the real-time sample rate and the requested packet interval rate. Their respective values dictate how often the owner controller receives data and how many multicasts from the module contain updated channel data.

In the example below, the real-time sample value is 100 ms and the requested packet interval value is 25 ms. Only each fourth multicast from the module contains updated channel data.

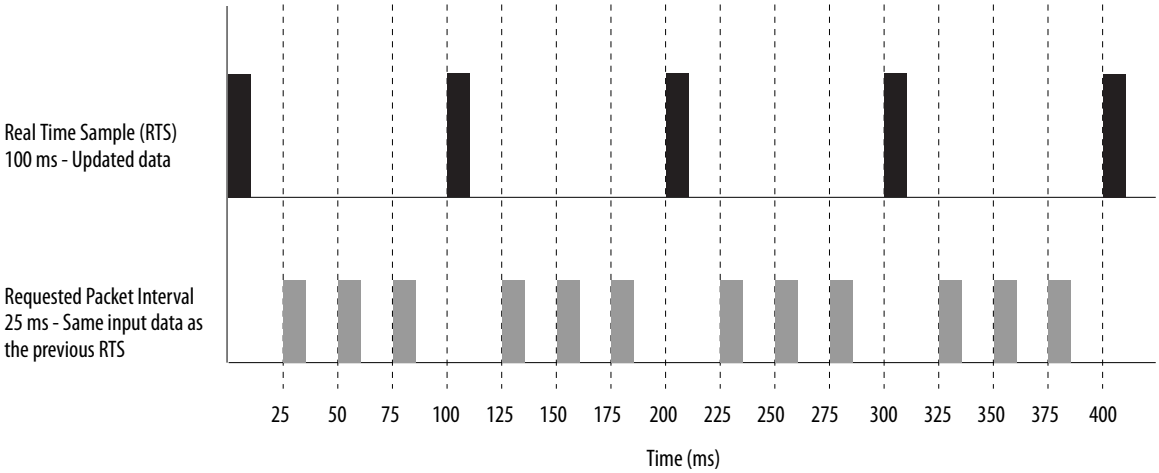

Trigger Event Tasks

When configured to do so, ControlLogix analog input modules can trigger execution of an event task in a controller. The event task feature lets you create a task that executes a section of logic immediately when an event (receipt of new data) occurs.

A ControlLogix analog I/O module can trigger event tasks each real-time sample, after the module has sampled and multicast its data. Event tasks are useful for synchronization of process variable (PV) samples and proportional integral derivative (PID) calculations.

IMPORTANT ControlLogix analog I/O modules can trigger event tasks at each real-time sample, but not at the requested packet interval. For example, in the figure, an event task can be only triggered each 100 ms.

Input Modules in a Remote Chassis

For an input module in a remote chassis, the roles of requested packet interval and real-time sample behavior change slightly regarding data communication to the owner controller. This change depends on what network type is used to communicate with the modules.

Remote Input Modules Connected Via ControlNet Network

Consider the case of an analog I/O module that is connected to the owner controller via a scheduled ControlNet network. In this case, the RPI and real-time sample interval define when the module multicasts data **within its own chassis**. Only the RPI value, however, determines how often the owner controller receives module data over the network.

The specified RPI not only instructs the module to multicast data within its own chassis, but reserves a spot in the data stream that flows across the ControlNet network. The timing of this reserved spot does not coincide with the exact RPI value. The control system makes sure that the owner controller receives data at least as often as the specified requested packet interval.

Input Module in Remote Chassis with Requested Packet Interval Reserving Spot in Flow of Data

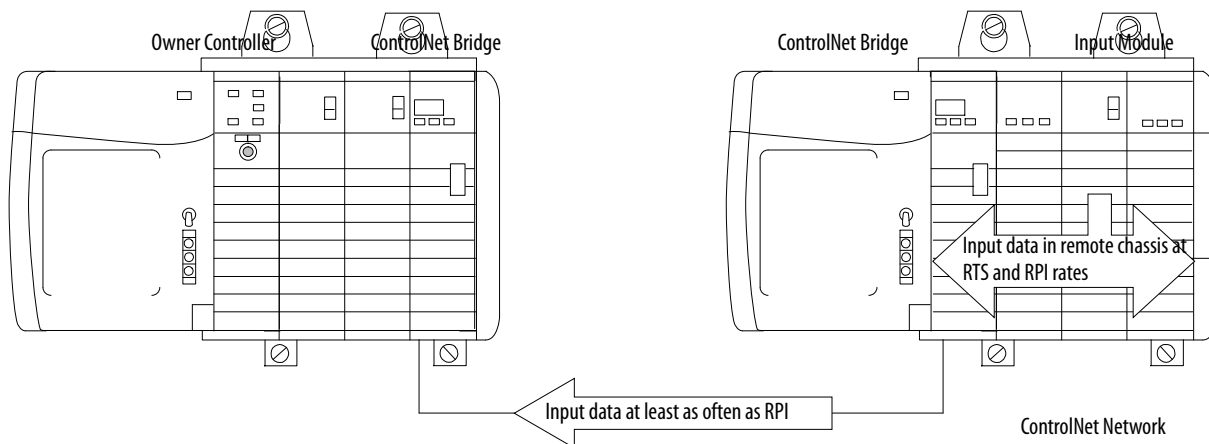

The reserved spot in the network data stream and the module real-time sample is asynchronous. So there are best and worst case scenarios as to when the owner controller receives updated channel data from the module in a networked chassis.

- **Best Case Scenario** - the module performs a real-time sample multicast with updated channel data just before the reserved network slot is made available. In this case, the remotely located owner controller receives the data almost immediately.
- **Worst Case Scenario** - the module performs a real-time sample multicast just after the reserved network slot has passed. In this case, the owner controller does not receive updated data until the next scheduled network slot.

RPI, not real-time sample interval, dictates when module data is sent over the network. Therefore, we recommend that you set the RPI less than or equal to the real-time sample interval. This setting helps make sure that the owner controller receives updated channel data with each receipt of data.

Remote Input Modules Connected Via EtherNet/IP Network

When remote analog input modules are connected to the owner controller via an EtherNet/IP network, data is transferred to the owner controller in the following way:

- At the RTS interval or RPI (whichever is faster), the module broadcasts data within its own chassis.
- The 1756 Ethernet bridge in the remote chassis immediately sends the module data over the network to the owner controller. This condition occurs only if the time since the last data transmission is more than 25% of the module RPI. Otherwise, no data is sent.

For example, if an analog input module has $RPI = 100$ ms, the Ethernet module sends module data immediately upon receipt if another data packet was not sent within the last 25 ms.

The Ethernet module either multicasts the module data to all devices on the network or unicasts to a specific owner controller depending on the setting of the Unicast box, as shown on [page 149](#).

TIP For more information, see the Guidelines to Specify an RPI Rate for I/O Modules section in the Logix5000 Controllers Design Considerations Reference Manual, publication [1756-RM094](#).

Output Module Operation

The RPI parameter governs when an analog output module receives data from the owner controller and when the output module echoes data. An owner controller sends data to an analog output module **once per RPI**. Data is not sent to the module at the end of the controller program scan.

When an analog output module receives **new data** from an owner controller (each RPI), it automatically multicasts, or echoes, a data value to the rest of the control system. This data value corresponds to the analog signal present at the output terminals of the module. This feature, called **Output Data Echo**, occurs whether the output module is local or remote.

TIP If the output module is not responding according to how it has been programmed, it could be for one of the following reasons:

- The commanded value falls outside the Configured Limits and is therefore being clamped.
- The commanded value changed faster than the configured max Rate Limit, and is being clamped.
- The module is in Start-up Hold mode following a connection break or Run mode transition. The module is waiting for the control system to synchronize with the prevailing setting to facilitate a bumpless startup.

Depending on the length of the RPI relative to the length of the controller program scan, an output module can receive and echo data multiple times during one program scan. The output module does not wait for the end of the program scan to send data. When RPI is less than program scan length, the controller effectively lets the module outputs change values multiple times during one program scan.

Output Modules in a Local Chassis

By specifying an RPI value for an analog output module, you instruct the controller when to broadcast output data to the module. If the module resides in the same chassis as the owner controller, the module receives the data almost immediately after the controller sends it.

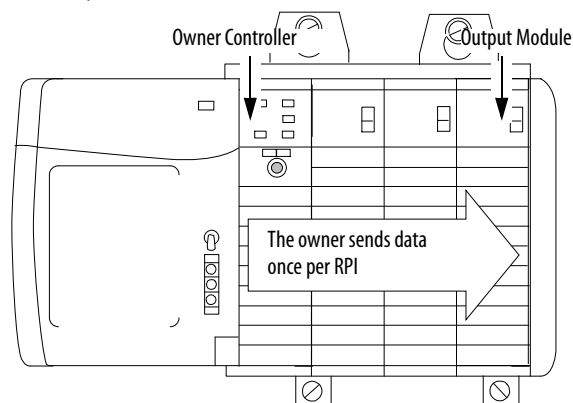

Output Modules in a Remote Chassis

For output modules in remote chassis, the role of RPI in getting data from the owner controller changes slightly, depending on the network.

Remote Output Modules Connected Via ControlNet Network

The RPI value instructs the controller to multicast output data within its own chassis, and reserves a spot in the stream of data that flows across the ControlNet network. These conditions occur when remote analog output modules are connected to the owner controller via a scheduled ControlNet network.

The timing of this reserved spot does or does not coincide with the exact value of the requested packet interval. However, the control system makes sure that the output module receives data **at least as often** as the specified requested RPI.

Output Module in Remote Chassis with Requested Packet Interval Reserving a Spot in Flow of Data

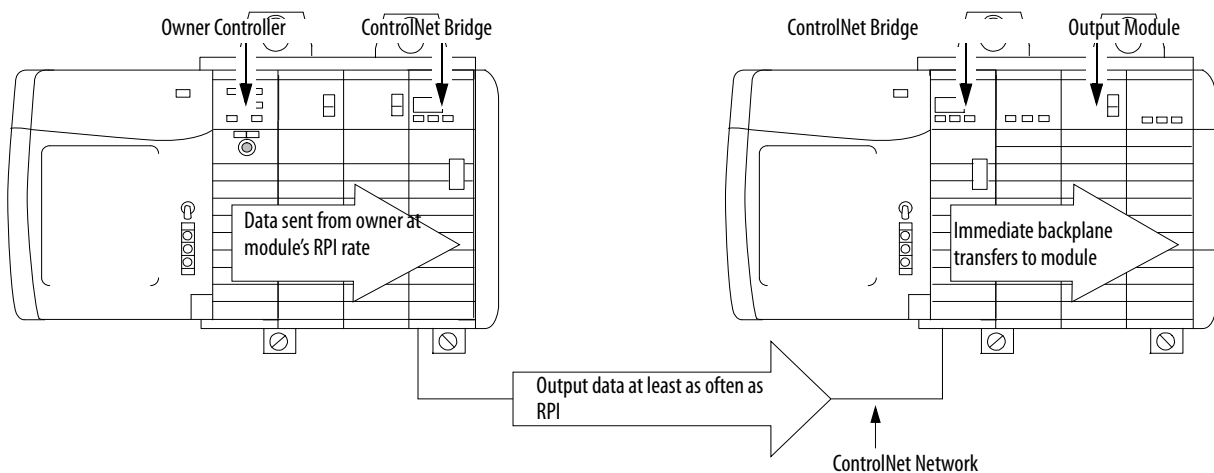

The reserved spot on the network and when the controller sends the output data are asynchronous. So there are best and worst case scenarios as to when the module receives the output data from the controller in a networked chassis.

- **Best Case Scenario** - the controller sends the output data just before the reserved network slot is available. In this case, the remotely located output module receives the data almost immediately.
- **Worst Case Scenario** - the controller sends the data just after the reserved network slot has passed. In this case, the module does not receive the data until the next scheduled network slot.

IMPORTANT These best and worst case scenarios indicate the time that is required for output data to transfer from the controller to the module once the controller has produced it.

The scenarios do not consider when the module receives new data (updated by the user program) from the controller. That result is a function of the length of the user program and its asynchronous relationship with the requested packet interval.

Remote Output Modules Connected Via EtherNet/IP Network

When remote analog output modules are connected to the owner controller via an EtherNet/IP network, the controller multicasts data in the following way:

- At the RPI, the owner controller multicasts data within its own chassis.
- The EtherNet/IP communication module in the local chassis immediately sends the data over the network to the analog output module. This condition occurs as long as it has not sent data within a time frame that is 1/4 the value of the requested packet interval of the analog module.

Listen-only Mode

Any controller in the system can listen to the data from any I/O module (that is, input data or 'echoed' output data) even if the controller does not own the module. In other words, the controller does not have to own the configuration data of a module to listen to it.

During the I/O configuration process, you can specify a 'Listen-Only' mode in the Connection box of the Module Definition section on the Module Properties dialog box. See [page 147](#) for more details.

In 'Listen-Only' mode, the controller and module establish communication without the controller sending any configuration data. Another controller owns the module being listened to.

IMPORTANT If a controller has a 'Listen-Only' connection to a module, the module cannot use the Unicast option for any connections over the EtherNet/IP network. See the Unicast box on [page 149](#).

The 'Listen-Only' controller continues to receive multicast data from the I/O module as long as a connection between an owner controller and the I/O module is maintained.

If the connection between all owner controllers and the module is broken, the module stops multicasting data and connections to all listening controllers are also broken.

Multiple Owners of Input Modules

Because listening controllers lose their connections to modules when communication with the owner stops, the ControlLogix system lets you define multiple owners for input modules.

IMPORTANT Only input modules can have multiple owners. If multiple owners are connected to the same input module, they must maintain identical configuration for that module.

In the example, Controller A and Controller B have both been configured as an owner of the input module.

Figure 1 - Multiple Owners with Identical Configuration Data

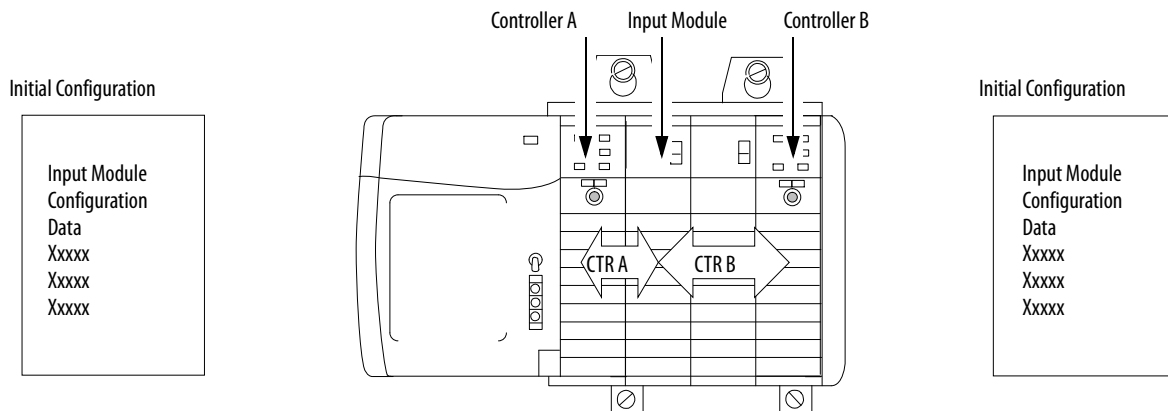

When multiple controllers are configured to own the same input module, the following events occur:

- When the controllers begin to download configuration data, both try to establish a connection with the input module.
- The controller data that arrives first establishes a connection.
- When data from the second controller arrives, the module compares it to its current configuration data (the data that was received and accepted from the first controller).
 - If the configuration data that the second controller sends matches the configuration data that the first controller sends, the connection is also accepted.
 - If any parameter of the second configuration data differs from the first, the module rejects the connection. The Logix Designer application alerts you to the rejected connection through an error message.

The module can continue to operate and multicast data even when one of the controllers loses its connection to the module. This feature is the advantage of multiple owners over a Listen-only connection.

Configuration Changes in an Input Module with Multiple Owners

You must be careful when you change the configuration data of an input module in a multiple owner scenario. When the configuration data is changed in one of the owners, for example, Controller A, and sent to the module, that configuration data is accepted as the new configuration for the module. Controller B continues to listen, unaware that any changes were made in the behavior of the module.

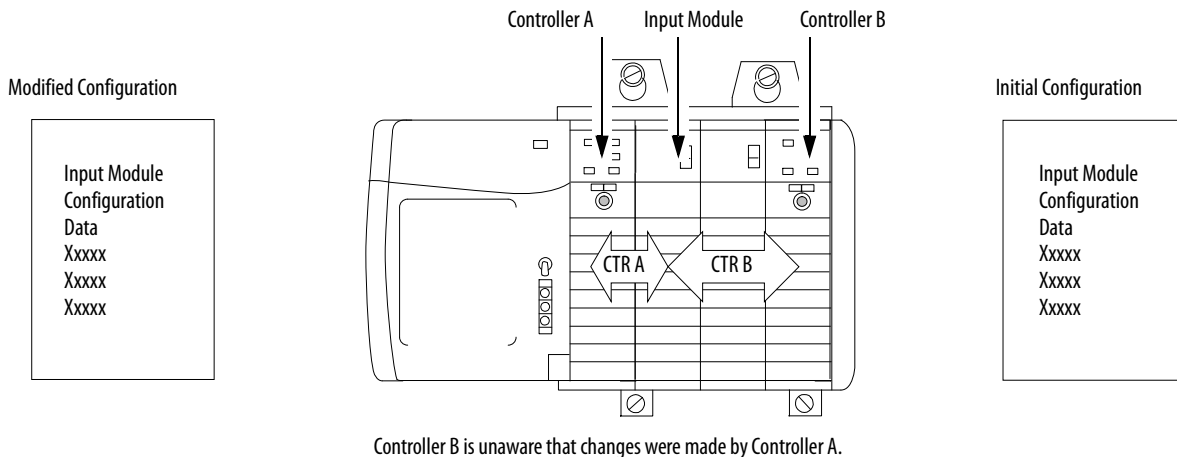

IMPORTANT A dialog box in the Logix Designer application alerts you to the possibility of a multiple owner situation. The same dialog box lets you inhibit the connection before changing the configuration of the module. When changing the configuration for a module with multiple owners, we recommend that you inhibit the connection.

To prevent other owners from receiving potentially erroneous data, follow these steps when changing a module configuration in a multiple owner scenario while online:

- For each owner controller, inhibit the controller connection to the module. You can inhibit the module in the software on the Connection tab or in the dialog box that warns of the multiple owner condition.
- Make the appropriate configuration data changes in the software, as described in the Logix Designer application section of this manual.
- Repeat the preceding steps for all owner controllers; make the same changes in all controllers.
- Disable the Inhibit box in each owner configuration.

Unicast Communication

Use unicast EtherNet/IP communication to reduce broadcast network traffic. Some facilities block multicast Ethernet packets as part of their network administration policy. You can configure multicast or unicast connections for I/O modules by using the Logix Designer application, version 18 or later.

Unicast connections do the following:

- Allow I/O communication to span multiple subnets
- Reduce network bandwidth
- Simplify Ethernet switch configuration

1756-IF8H HART Analog Input Module

This chapter discusses these topics.

Topic	Page
Module Features	33
Wire the Module	40
Circuit Diagrams	42
1756-IF8H Module Fault and Status Reporting	43
1756-IF8H Tag Definitions	46

Module Features

The 1756-IF8H module has the following features:

- Choice of three data formats
 - Analog only
 - Analog and HART PV
 - Analog and HART by channel)

IMPORTANT The Analog and HART by Channel data type is available only for 1756-IF8H firmware revision 2.001 or later.

- Multiple current and voltage input ranges
- Module filter
- Real-time sampling
- Underrange and overrange detection
- Process alarms
- Rate alarm
- Wire-off detection
- Highway addressable remote transducer (HART) communication

Data Formats

Data format determines which values are included in the Input tag of the module and the features that are available to your application. Select the data format on the General tab in the Studio 5000 Logix Designer® application. The following data formats are available for the 1756-IF8H module.

Format	Description			
	Analog signal values	Analog status	HART secondary process variables and device health	HART and Analog data for each channel are grouped in tag
Analog Only	X	X		
Analog and HART PV	X	X	X	
Analog and HART by Channel ⁽¹⁾	X	X	X	X

(1) Available only for 1756-IF8H firmware revision 2.1. or later

Choose Analog and HART PV if you prefer the members of the tag to be arranged similar to non-HART analog input modules. The analog values for all channels are grouped near the end of the tag. This option makes it easy to view all eight analog values at once.

Choose Analog and HART by Channel if you prefer Status, Analog Value, and Device Status for each channel to be together in the tag. This arrangement makes it easier to view all data that is related to one field device.

Input Ranges

You can select from a series of operational ranges for each channel on the module. The range designates the minimum and maximum signals that are detectable by the module. Possible ranges include the following:

- -10...10V
- 0...5V
- 0...10V
- 0...20 mA
- 4...20 mA (HART instruments use this range.)

Module Filter

The module filter attenuates the input signal at the specified frequency and above. This feature is applied on a module-wide basis and affects all channels.

The module filter attenuates the selected frequency by approximately -3 dB or 0.707 of the applied amplitude. An input signal with frequencies above the selected frequency is attenuated more while frequencies below the selection receive no attenuation.

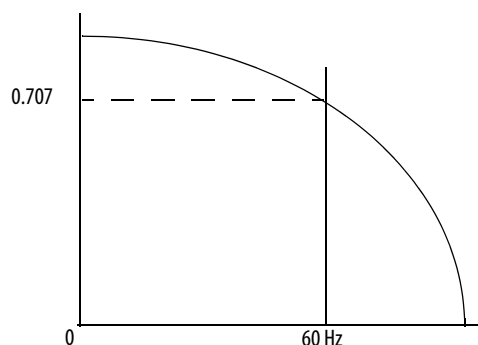

In addition to frequency rejection, a by-product of the filter selection is the minimum sample rate (RTS) that is available. For example, the 1000 Hz selection does not attenuate any frequencies less than 1000 Hz, and provides for sampling of all 16 channels within 18 ms. The 10 Hz selection attenuates all frequencies above 10 Hz and provides for sampling all 16 channels only within 488 ms.

IMPORTANT 60 Hz is the default setting for the module filter.
Do not use the 1000 Hz module filter with HART instruments.

Use [Table 3](#) to choose a module filter setting.

Table 3 - Module Filter Selections with Associated Performance Data

Module Filter Setting (-3 dB)	10 Hz	15 Hz	20 Hz	50 Hz	60 Hz	100 Hz	250 Hz	1000 Hz
Minimum Sample Time (ms) (RTS) ⁽¹⁾	488	328	248	88	88	56	28	18
Effective Resolution (+/-10V range)	17 bits	17 bits	17 bits	16 bits	16 bits	15 bits	14 bits	12 bits
	0.16 mV	0.16 mV	0.16 mV	0.31 mV	0.31 mV	0.62 mV	1.25 mV	5.0 mV
Effective Resolution (0...10V range)	16 bits	16 bits	16 bits	15 bits	15 bits	14 bits	13 bits	11 bits
	0.16 mV	0.16 mV	0.16 mV	0.31 mV	0.31 mV	0.62 mV	1.25 mV	5.0 mV
Effective Resolution (0...5V, 0...20 mA, 4...20 mA range)	15 bits	15 bits	15 bits	14 bits	14 bits	13 bits	12 bits	10 bits
	0.16 mV 0.63 μ A	0.16 mV 0.63 μ A	0.16 mV 0.63 μ A	0.31 mV 1.25 μ A	0.31 mV 1.25 μ A	0.62 mV 2.5 μ A	1.25 mV 5.0 μ A	5.0 mV 20.0 μ A
-3 dB Frequency	7.80 Hz	11.70 Hz	15.60 Hz	39.30 Hz	39.30 Hz	65.54 Hz	163.9 Hz	659.7 Hz
50 Hz Rejection	95 dB	85 dB	38 dB	4 dB	4 dB	2 dB	0.5 dB	0.1 dB
60 Hz Rejection	97 dB	88 dB	65 dB	7 dB	7 dB	2.5 dB	0.6 dB	0.1 dB

(1) Worst case settling time to 100% of a step change is double the real-time sample time.

Real-time Sampling

This parameter instructs the module how often to scan its input channels and obtain all available data. After the channels are scanned, the module multicasts that data. This feature is applied on a module-wide basis.

During module configuration, you specify a real-time sampling (RTS) period and a requested packet interval (RPI) period. Both of these features instruct the module to multicast data, but only the RTS feature instructs the module to scan its channels before multicasting.

For more RTS information, see [Real Time Sample \(RTS\) on page 23](#).

Underrange and Overrange Detection

The module detects when it is operating beyond limits of the input range. This status indication tells you that the input signal is not being measured accurately because the signal is beyond the measuring capability of the module. For example, the module cannot distinguish between 10.25V and 20V.

[Table 4](#) shows the input ranges of the 1756-IF8H module and the lowest and highest signal available in each range before the module detects an underrange and overrange condition.

Table 4 - Low and High Signal Limits on the 1756-IF8H Module

Input Module	Available Range	Lowest Signal in Range	Highest Signal in Range
1756-IF8H	-10...10V	-10.25V	10.25V
	0...10V	0V	10.25V
	0...5V	0V	5.125V
	0...20 mA	0 mA	20.58 mA
	4...20 mA	3.42 mA	20.58 mA

Digital Filter

The digital filter smooths input data noise transients. This feature is applied on a **per channel** basis.

The digital filter value specifies the time constant for a digital first order lag filter on the input. It is specified in units of milliseconds. A value of 0 disables the filter.

The digital filter equation is a classic first order lag equation.

$$Y_n = Y_{n-1} + \frac{[\Delta t]}{\Delta t + T_A} (X_n - Y_{n-1})$$

Y_n = present output, filtered peak voltage (PV)

Y_{n-1} = previous output, filtered PV

Δt = module channel update time (seconds)

T_A = digital filter time constant (seconds)

X_n = present input, unfiltered PV

[Figure 2](#) illustrates filter response to a step input. When the digital filter time constant elapses, 63.2% of the total response is reached. Each additional time constant achieves 63.2% of the remaining response.

Figure 2 - Filter Response

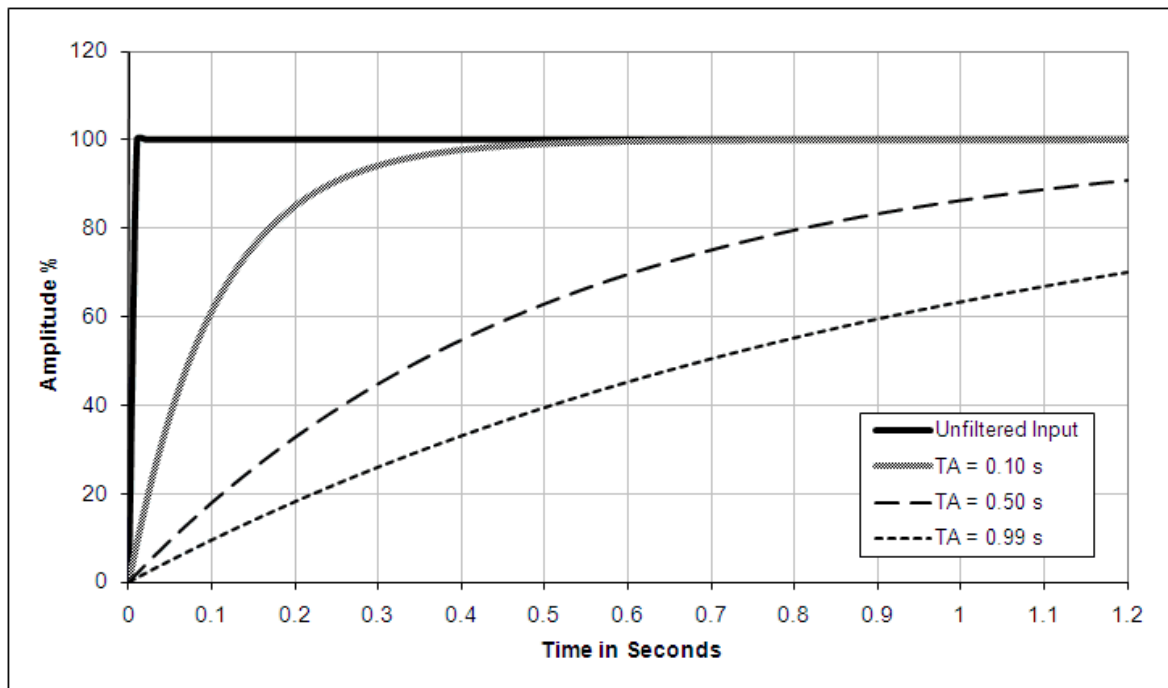

Process Alarms

Process alarms alert you when the module has exceeded configured high or low thresholds for **each channel**. You can latch process alarms. These alarms are set at the following configurable trigger points:

- High high
- High
- Low
- Low low

The values for each limit are entered in scaled engineering units.

Alarm Deadband

You can configure an alarm deadband to work with the process alarms. The deadband lets the process alarm status bit remain set, despite disappearance of the alarm condition, as long as the input remains within the process alarm deadband.

[Figure 3](#) shows input data that sets each of the alarms at some point during module operation. In this example, Latching is disabled; therefore, each alarm turns OFF when the condition that caused it to set returns to normal.

Figure 3 - Input Data That Sets Each of the Alarms

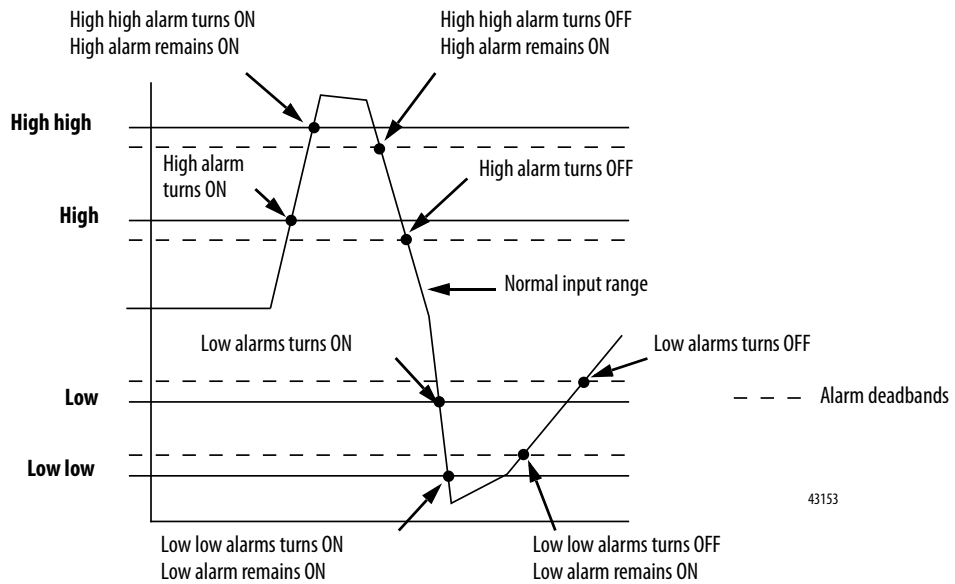

Rate Alarm

The value for the Rate Alarm Limit is entered in scaled engineering units per second. The rate alarm triggers if the rate of change between input samples for each channel exceeds the specified rate-alarm trigger point for that channel. Rate Alarm uses the signal value after filtering by the Module Filter and before the Digital Filter is applied.

Wire-off Detection

The 1756-IF8H modules alert you when a signal wire is disconnected from one of its channels or the RTB is removed from the module. When a wire-off condition occurs for this module, two events occur:

- Input data for that channel changes to a specific scaled value.
- A fault bit is set in the input tag, which can indicate the presence of a wire-off condition.

Because 1756-IF8H modules can be applied in voltage or current applications, differences exist as to how a wire-off condition is detected in each application.

[Table 5](#) identifies the conditions that are reported in the input tag when a wiring anomaly is detected.

Table 5 - Wire-off Detection

	Input Range	Wiring Problem	Condition Reported in Input Tag			
			Input Data Changes to	ChXOverrange	ChXBrokenWire	ChXUnderrange
Voltage	-10V...+10V 0V...+5V 0V...+10V	INx or INx removed	Maximum scaled value (overrange value)	1	1	
Current	0...20 mA	RTB removed or INx and I RTN-x jumper removed	Maximum scaled value (overrange value)	1	1	
		Only INx removed (jumper in place)	Minimum scaled value (underrange value)		0	1
		Only jumper removed	Maximum scaled value (overrange value)	1	1	
	4...20 mA	RTB removed or INx and I RTN-x jumper removed	Maximum scaled value (overrange value)	1	1	
		Only INx removed (jumper in place)	Minimum scaled value (underrange value)		1	1
		Only jumper removed	Maximum scaled value (overrange value)	1	1	

Wire the Module

Use [Figure 4](#) to wire the module for voltage and current inputs. HART communication is active with current inputs only.

Figure 4 - 1756-IF8H Voltage and Current Inputs

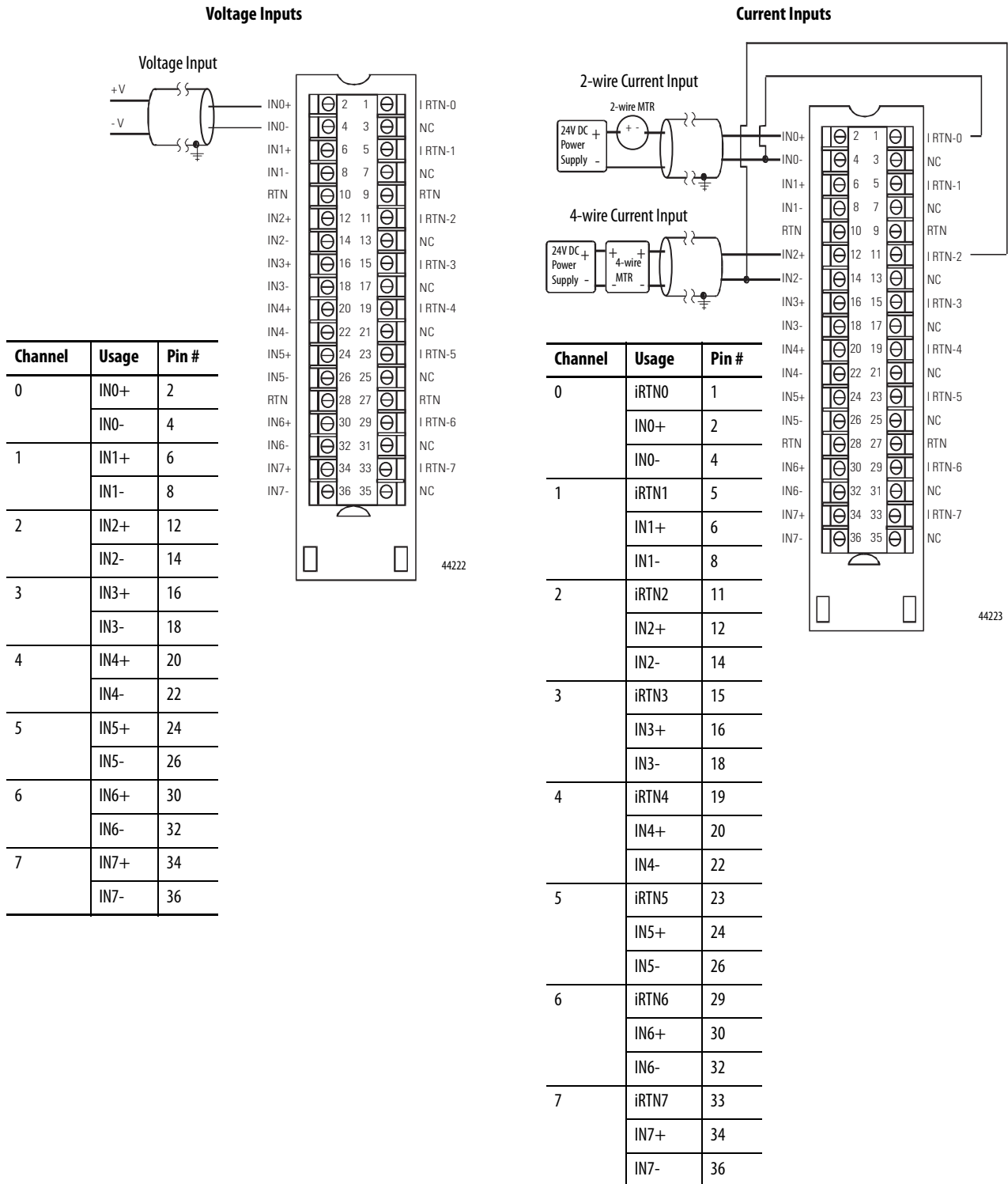

The 1756-IF8H is a [differential](#) input module. However, there are limitations on its use in differential mode. Any time the low ends of the terminal block pins are connected together, they must also be jumpered to the RTN pin on the terminal block. There are two scenarios in which this condition happens.

First, if one power supply is used for multiple devices, then the low ends from all channels are connected together and connected to the ground return of the power supply. See [Figure 5](#).

Figure 5 - Single Power Supply with Multiple HART Devices

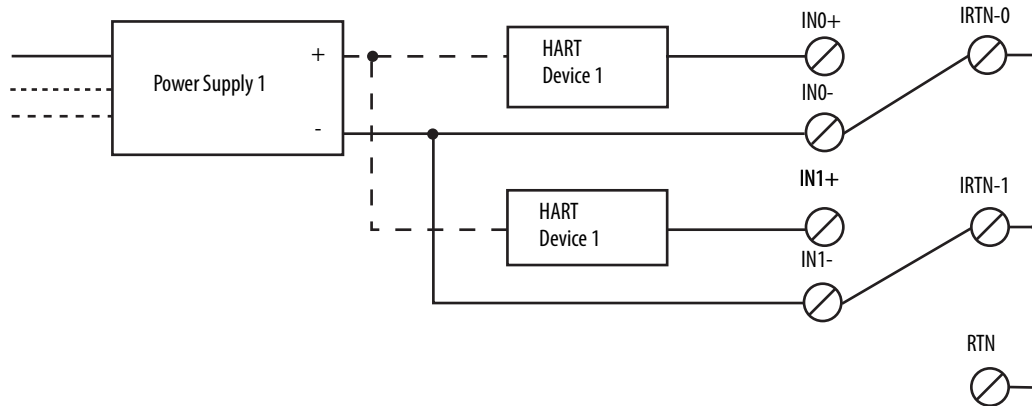

The second way for channels to share a ground is to have multiple power supplies connected to the same ground. In this case, the low ends of the channels are effectively connected together by the common ground of the power supplies.

Figure 6 - Multiple Power Supplies with a Common Ground

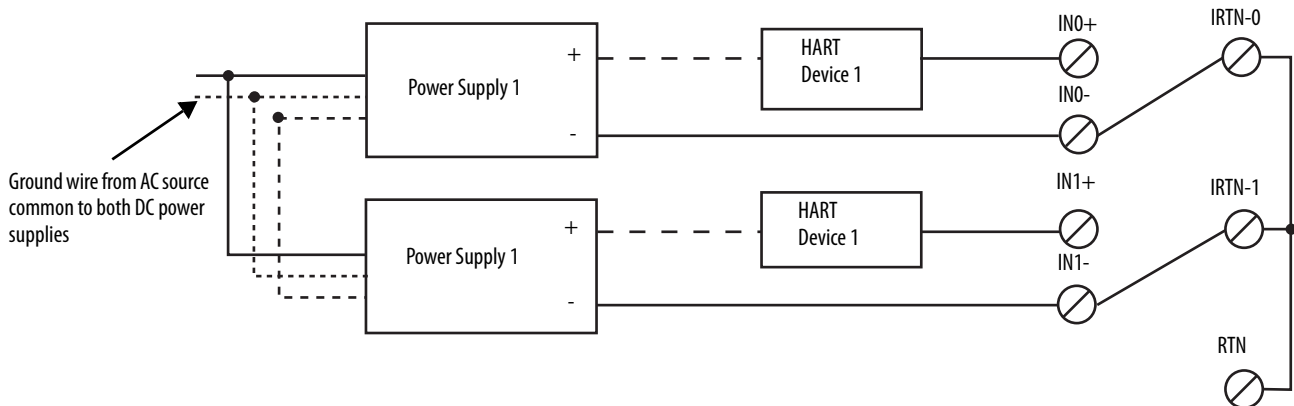

For devices powered by individual supplies, when the ground potential of the supplies is expected to differ, differential mode is recommended. This practice prevents ground loop currents from flowing between the supplies. However, the potential difference allowable between the supplies must remain within specified limits.

Figure 7 - Power Supplies with Isolated Grounds

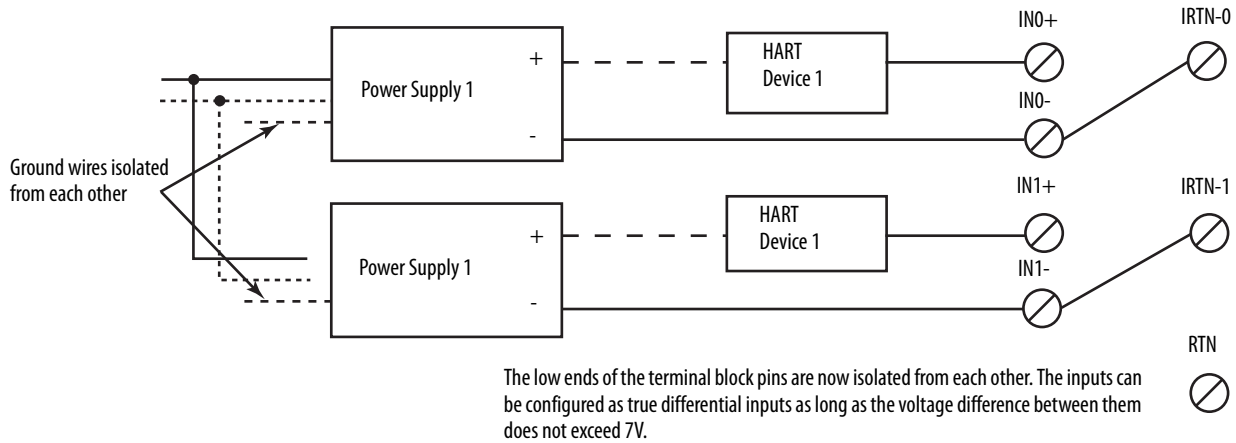

We recommend that some devices, such as AC powered four-wire devices, be used in differential mode only. It is best if differential and [single-ended](#) input types are not connected on the same terminal block. We recommend that you connect differential inputs and single-ended inputs to different terminal blocks.

Circuit Diagrams

This section shows circuit diagrams for the 1756-IF8H module.

Figure 8 - Simplified 1756-IF8H Current Input Circuit

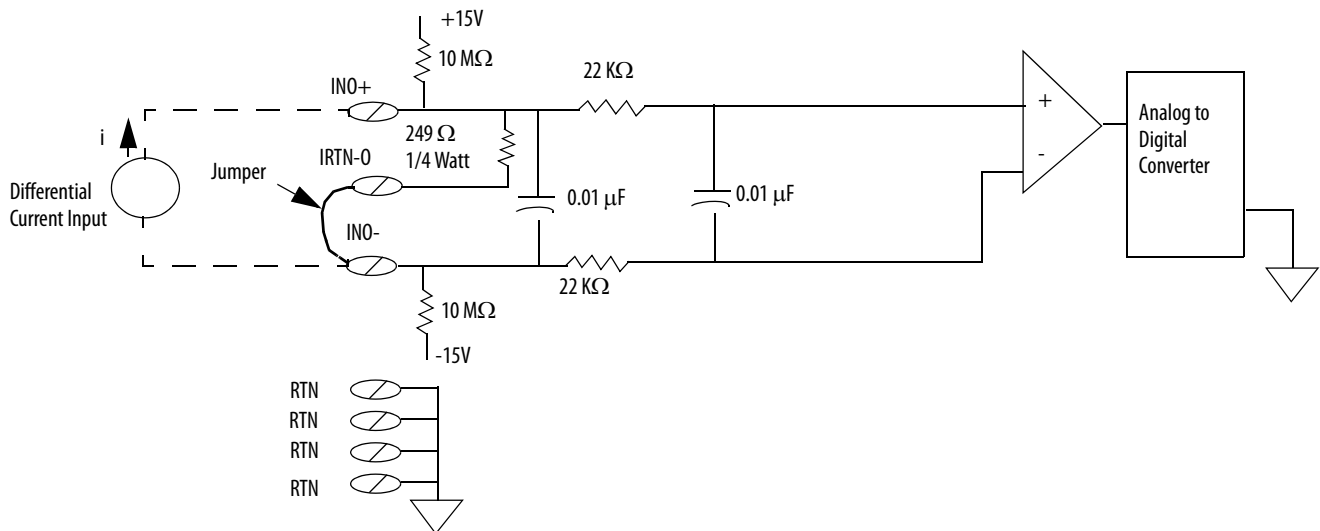
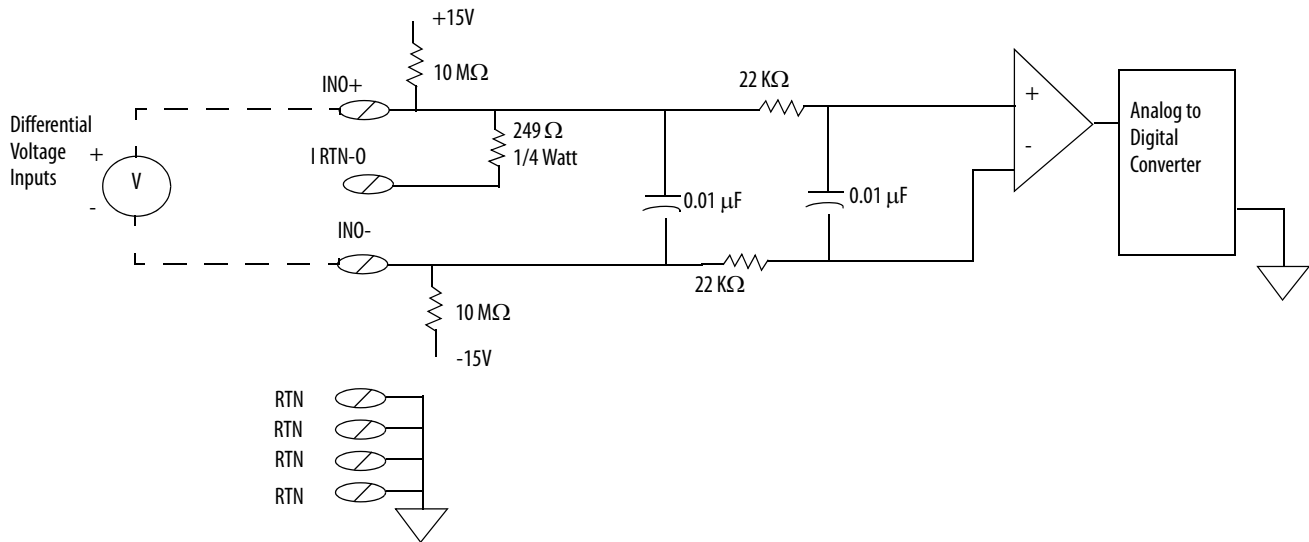

Figure 9 - Simplified 1756-IF8H Voltage Input Circuit



1756-IF8H Module Fault and Status Reporting

The 1756-IF8H module multicasts status/fault data to the controller with its channel data. The fault data is arranged to let you choose the level of granularity you desire to examine fault conditions. Three levels of tags work together to provide an increasing degree of detail as to the specific cause of faults on the module.

[Table 6](#) lists tags you can examine in ladder logic to indicate when a fault has occurred.

Table 6 - 1756-IF8H Tags That Can Be Examined in Ladder Logic

Tag	Description	Tag Name Analog and HART PV	Tag Name Analog and HART by Channel ⁽¹⁾
Module Fault Word	This word provides fault summary reporting.	ModuleFaults	ModuleFaults
Channel Fault Word	This word provides underrange, overrange, and communication fault reporting.	ChannelFaults ChxFault	ChannelFaults ChxFault
Channel Status Word	These words provide individual channel underrange and overrange fault indications and report process alarms, rate alarms, and calibration faults.	ChxStatus	Chx.DeviceStatus Chx.DeviceStatus.AlarmStatus
HART Faults	These bits provide HART communication status.	HARTFaults, ChxHARTFault	Chx.DeviceStatus.HARTFault
HART Device Status	This data reports HART field device health.	HART.ChxDevice Status	Chx.DeviceStatus.FieldDeviceStatus

(1) Available only for 1756-IF8H firmware revision 2.001.

1756-IF8H Fault Reporting

Figure 10 shows how the 1756-IF8H module reports faults.

Figure 10 - 1756-IF8H Module Fault Reporting

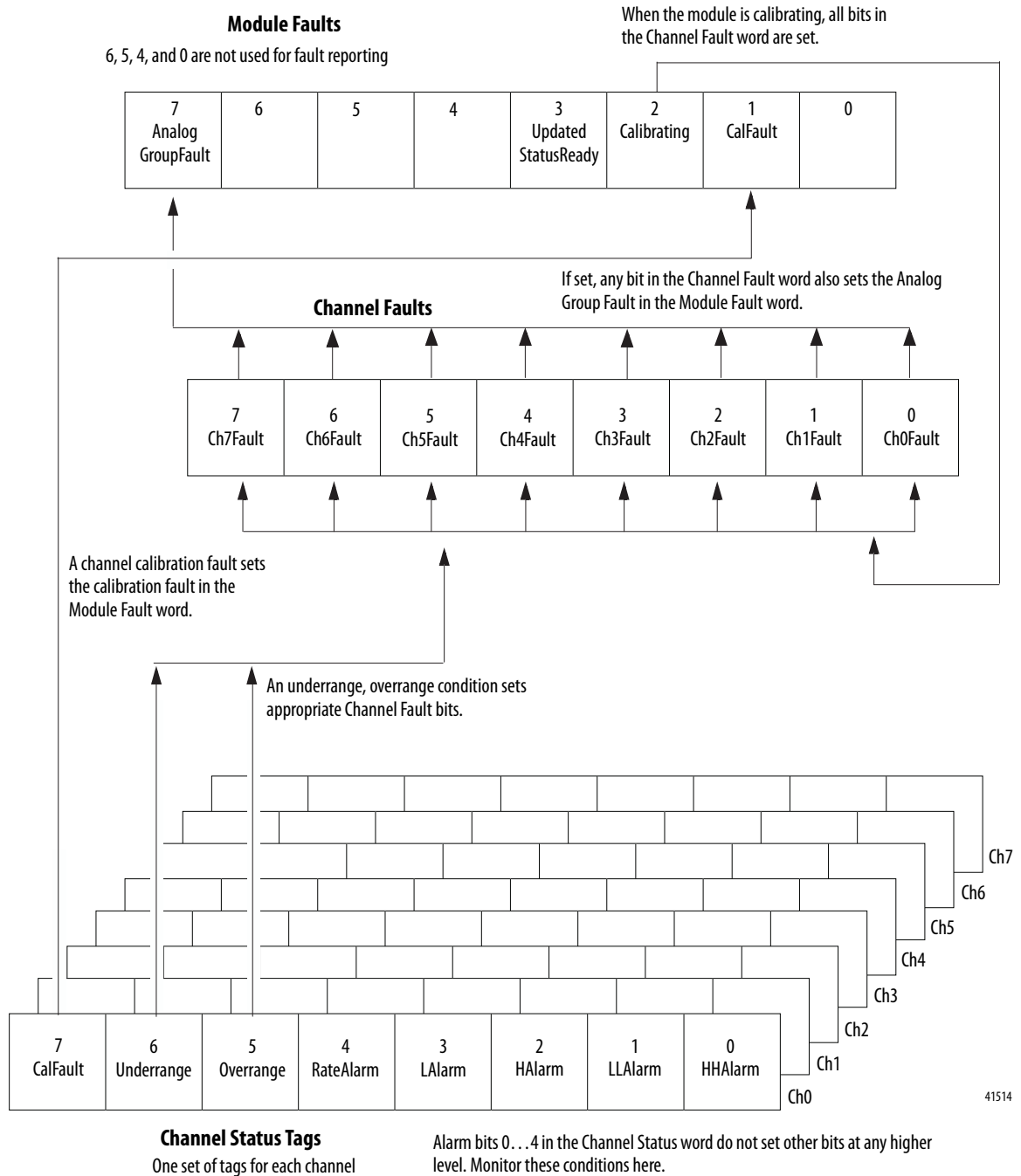

1756-IF8H Module Fault Word Bits

Bits in this word provide the highest level of fault detection. A nonzero condition in this word reveals that a fault exists on the module. You can examine further to isolate the fault. [Table 7](#) lists tags that can be examined in ladder logic to indicate when a fault has occurred.

Table 7 - 1756-IF8H Tags That Can Be Examined in Ladder Logic

Tag	Description
Analog Group Fault	This bit is set when any bits in the Channel Fault word are set. Its tag name is AnalogGroupFault.
Calibrating	This bit is set when any channel is being calibrated. When this bit is set, all bits in the Channel Fault word are set. Its tag name is Calibrating.
Calibration Fault	This bit is set when any of the individual Channel Calibration Fault bits are set. Its tag name is CalFault.

1756-IF8H Channel Fault Tags

During normal module operation, bits in the Channel Fault word are set if any of the respective channels has an Underrange or Overrange condition. Examine this word for a nonzero value to check quickly for Underrange or Overrange conditions on the module.

[Table 8](#) lists conditions that set **all** Channel Fault word bits.

Table 8 - 1756-IF8H Conditions That Set All Channel Fault Word Bits

This Condition Sets All Channel Fault Word Bits	And Causes the Module to Display the Following in the Channel Fault Word Bits
A channel is being calibrated	16#00FF
A communication fault occurred between the module and its owner-controller	16#FFFF

1756-IF8H Channel Status Tags

[Table 9](#) describes the channel status tags.

Table 9 - 1756-IF8H Tags That Show Channel Status

Tag	Bit	Description
ChxCalFault	7	This bit is set if an error occurs during calibration for Channel <i>x</i> , which can cause a bad calibration. Also sets CalFault in the Module Faults.
ChxUnderrange	6	This bit is set when the analog signal is less than or equal to the minimum detectable signal. Because the signal cannot be measured, it can be significantly below the minimum value. Also sets ChxFault in the Channel Faults.
ChxOverrange	5	This bit is set when the analog signal is greater than or equal to the maximum detectable signal. Because the signal cannot be measured, it can be significantly above the maximum value. Also sets ChxFault in the Channel Faults.
ChxRateAlarm ⁽¹⁾	4	This bit is set when the rate of change between input samples for each channel exceeds the specified rate-alarm trigger point for the channel. Both positive and negative changes can cause this alarm.
ChxLAlarm	3	This bit is set when the requested input value is less than the configured low limit value. It remains set until the requested input is greater than the low limit. If the bit is latched, it remains set until it is unlatched.
ChxHAlarm	2	This bit is set when the requested input value is greater than the configured high limit value. It remains set until the requested input is less than the high limit. If the bit is latched, it remains set until it is unlatched.
ChxLLAlarm	1	This bit is set when the requested input value is less than the configured low low limit value. It remains set until the requested input is greater than the low low limit. If the bit is latched, it remains set until it is unlatched.
ChxHHALarm	0	This bit is set when the requested input value is greater than the configured high high limit value. It remains set until the requested input is less than the high high limit. If the bit is latched, it remains set until it is unlatched.

(1) Alarm bits 0...4 in the Channel Status word do not set other bits at any higher level.

1756-IF8H Tag Definitions

[Table 10...Table 14](#) describe module-defined data types for the 1756-IF8H module and include information for configuration and input tags.

Available tags depend on the selected input data format, as shown in [Table 10](#).

Table 10 - 1756-IF8H Input Data Choice and Tags

Input Data Choice	Tag	Main Module Defined Type	Subtype Used by Main Type
Analog Only	Configuration	AB:1756_IF8H:C:0	AB:1756_IF8H_ChConfig_Struct:C:0
	Input	AB:1756_IF8H_Analog:I:0	None
Analog and HART PV	Configuration	AB:1756_IF8H:C:0	AB:1756_IF8H_ChConfig_Struct:C:0
	Input	AB:1756_IF8H_HARTPV:I:1	AB:1756_IF8H_HARTData:I:1 AB:1756_IF8H_HARTStatus_Struct:I:1
Analog and HART by Channel	Configuration	AB:1756_IF8H:C:0	AB:1756_IF8H_ChConfig_Struct:C:0
	Input	AB:1756_IF8H_AnalogHARTbyChannel:I:0	AB:1756_IF8H_HARTDataAll_Struct:I:0 AB:1756_IF8H_HARTStatusAll_Struct:I:0

Configuration

[Table 11](#) describes the configuration tags available in the 1756-IF8H module.

Table 11 - 1756-IF8H Configuration Tags - (AB:1756_IF8H:C:0)

Member Name	Type	Style	Description
ModuleFilter (bits 0...7)	SINT	Decimal	See the Module Filter Selections with Associated Performance Data table on page 35 .
RealTimeSample (bits 0...15)	INT	Decimal	Milliseconds between reading signal values. See Real Time Sample (RTS) on page 23 for more information.
ChxConfig (x=0...7)	AB:1756_IF8H_ChConfig_Struct:C:0		
Config	SINT	Binary	
RateAlarmLatch	BOOL	Decimal	Ch0Config.Config.4, After a Rate Alarm is detected, keep I.ChxRateAlarm set even after Rate returns to normal, until unlatched by CIP Service Message.
ProcessAlarmLatch	BOOL	Decimal	Ch0Config.Config.5, After a Process Alarm such as LL is detected, keep I.ChxLLAlarm set even after measurement returns to normal, until unlatched by CIP Service Message.
AlarmDisable	BOOL	Decimal	Ch0Config.Config.6, Do not report Process or Rate Alarms.
HARTEn	BOOL	Decimal	Ch0Config.Config.7, Enable HART communication. Must be 1 for valid HART data in Input Tag and Asset Management access to HART Field Device.
RangeType	SINT	Decimal	0 = -10...+10 V. 1 = 0...5 V. 2 = 0...10 V. 3 = 0...20 mA. 4 = 4...20 mA.
DigitalFilter	INT	Decimal	Time Constant of low pass filter in ms. See Digital Filter on page 37 for more information.
RateAlarmLimit	REAL	Float	Maximum Ramp Rate value to trigger a Rate Alarm when the Input Signal rate of change exceeds the setpoint. See Scaling to Engineering Units on page 153 for more information.
LowSignal	REAL	Float	Lower current value for scaling to engineering units. Default is 4 mA. Must be less than HighSignal and more than or equal to the minimum Input Range. See Scaling to Engineering Units on page 153 for more information.
HighSignal	REAL	Float	Upper current value for scaling to engineering units. Default is 20 mA. Must be more than LowSignal and less than or equal to the maximum Input Range. See Scaling to Engineering Units on page 153 for more information.
LowEngineering	REAL	Float	Measured quantity in engineering units that results in a signal level equal to LowSignal. See Scaling to Engineering Units on page 153 for more information.
HighEngineering	REAL	Float	Measured quantity in engineering units that results in a signal level equal to HighSignal. See Scaling to Engineering Units on page 153 for more information.
LAlarmLimit	REAL	Float	User value sets low limit that causes the module to trigger a low alarm.
HAlarmLimit	REAL	Float	User value sets high limit that causes the module to trigger a high alarm.
LLAlarmLimit	REAL	Float	User value sets low low limit that causes the module to trigger a low low alarm.
HHAlarmLimit	REAL	Float	User value sets high high limit that causes the module to trigger a high high alarm.
AlarmDeadband	REAL	Float	Specifies the deadband range for the alarm trigger point. See Figure 3 on page 38 for an illustration.
CalBias	REAL	Float	Sensor Offset in engineering units added to the measured signal before reporting Ch0.Data.
PassthroughHandle Timeout	INT	Decimal	Seconds to keep a reply to a HART pass-through service request before discarding. 15 seconds recommended.
PassthroughCmdFreq_14	BOOL	Decimal	Selects the policy for sending HART pass-through messages. See Pass-through Setting, Ratio, and Priority (Input Modules) on page 156
PassthroughCmdFreq_15	BOOL	Decimal	

Analog Only

Table 12 describes the input tags available in the Analog Only data format.

Table 12 - 1756-IF8H Input Tags - Analog Only (AB:1756_IF8H_Analog:I:0)

Member Name	Type	Style	Description
ChannelFaults	INT	Binary	Indicates a problem with analog data on Channel x or broken communication between the Logix controller and the 1756-IF8H module. Example: Set if analog signal is larger than 20 mA.
ChxFault (Ch0...Ch7)	BOOL	Decimal	ChannelFaults.0...ChannelFaults.7
ChxBrokenWire (Ch0...Ch7)	BOOL	Decimal	ChannelFaults.8...ChannelFaults.15 Indicates that current is not flowing through the module as expected. Broken wiring, RTB removal, or a powered-off field device can cause this indication.
HARTFaults (Ch0...Ch7)	SINT	Binary	Indicates a problem with HART data from the Field Device on Channel x. Examples are HART not enabled, HART device not connected, HART communication failure due to noise. These Field Device Status conditions also cause this to be set: Device Malfunction, PV Out of Limits, Loop Current Saturated, and Loop Current Fixed.
ChxHARTFault	BOOL	Decimal	HARTFaults.0...HARTFaults.7
ModuleFaults	SINT	Binary	Module level fault status bits
CalFault	BOOL	Decimal	(ModuleFaults.1) 1756-IF8H Module Calibration Failed.
Calibrating	BOOL	Decimal	(ModuleFaults.2) Calibration in progress.
AnalogGroupFault	BOOL	Decimal	(ModuleFaults.7) Indicates that a fault has occurred on any channel (any of ChannelFaults).
ChxStatus (Ch0...Ch7)	SINT	Binary	Indicates various alarms on the analog signal. Also sets Ch0Fault for Overrange, Underrange and CalFault.
ChxHHAAlarm	BOOL		ChxStatus.0 ChxData > ChxHHAAlarmLimit. If Process Alarms are configured to Latch by setting ChxConfig.ProcessAlarmLatch this bit remains set even after the condition returns to normal, until reset via explicit CIP message. This message can be sent from the Studio 5000® Module Properties Alarm dialog box or from the Logix controller via MSG instruction.
ChxLLAlarm	BOOL		ChxStatus.1 ChxData < ChxLLAlarmLimit If ChxConfig.ProcessAlarmLatch is set, this alarm remains set until it is unlatched
ChxHAlarm	BOOL		ChxStatus.2 ChxData > ChxHAlarmLimit If ChxConfig.ProcessAlarmLatch is set, this alarm remains set until it is unlatched
ChxLAlarm	BOOL		ChxStatus.3 ChxData < ChxLAlarmLimit If ChxConfig.ProcessAlarmLatch is set, this alarm remains set until it is unlatched
ChxRateAlarm	BOOL		ChxStatus.4 ChxData changing faster than ChxRateAlarmLimit. Both Positive and Negative changes can cause this alarm. If ChxConfig.RateAlarmLatch is set, this alarm remains set until it is unlatched
ChxOverrange	BOOL		ChxStatus.5 Analog signal is greater than or equal to the maximum detectable signal. Because the signal cannot be measured, it can be significantly above the maximum value
ChxUnderrange	BOOL		ChxStatus.6 Analog signal is less than or equal to the minimum detectable signal. Because the signal cannot be measured, it can be significantly below the minimum value
ChxCalFault	BOOL		ChxStatus.7 Set if an error occurs during calibration for Channel x, which causes a bad calibration. Also sets CalFault
ChxData (Ch0...Ch7)	REAL	Float	Value of analog signal on Channel x after conversion to engineering units.
CSTimestamp	DINT[2]	Hex	Timestamp that is taken at the time the input data was sampled in terms of coordinated system time, which is a 64-bit value in microseconds coordinated across the modules in the 1756 backplane.
RollingTimestamp	INT	Decimal	Timestamp that is taken at the time the input data was sampled in millisecond resolution.

Analog and HART PV

[Table 13](#) describes the input tags available in the Analog and HART PV data format.

Table 13 - 1756-IF8H Input Tags - Analog and HART PV (AB:1756_IF8H_HARTPV:I:1)

Member Name	Type	Style	Description
ChannelFaults	INT	Binary	Indicates a problem with analog data on Channel x or broken communication between the Logix controller and the 1756-IF8H module (bits 0...15). Example: Set if analog signal is larger than 20 mA.
ChxFault (Ch0...Ch7)	BOOL	Decimal	ChannelFaults.0...ChannelFaults.7
ChxBrokenWire (Ch0...Ch7)	BOOL	Decimal	ChannelFaults.8...ChannelFaults.15 Indicates that current is not flowing through the module as expected. Broken wiring, RTB removal, or a powered-off field device can cause this condition.
HARTFaults	SINT	Binary	Indicates a problem with HART data from the field device on Channel x (bits 0...7). Examples are HART not enabled, HART device not connected, HART communication failure due to noise. These field device status conditions also cause this to be set: Device Malfunction, PV Out of Limits, Loop Current Saturated, and Loop Current Fixed.
ChxHARTFault (Ch0...Ch7)	BOOL	Decimal	HARTFaults.0...HARTFaults.7
ModuleFaults	SINT	Binary	Module level fault status (bits 0...7)
CalFault	BOOL	Decimal	(ModuleFaults.1) 1756-IF8H Module Calibration Failed.
Calibrating	BOOL	Decimal	(ModuleFaults.2) Calibration in progress.
UpdatedStatusReady	BOOL	Decimal	(ModuleFaults.3) Module has collected updated Additional Device Status from HART command 48. This status can be retrieved by using the Read Additional Status service, 16#4C. For more information about this service, see Read Additional Status (Service Code = 16#4C) on page 181 . Updated Cmd 48 status data available.
AnalogGroupFault	BOOL	Decimal	(ModuleFaults.7) Indicates that a fault has occurred on any channel (any of ChannelFaults).
ChxStatus (Ch0...Ch7)	SINT	Binary	Indicates various alarms on the analog signal. Also sets ChxFault for Overrange, Underrange, and CalFault.
ChxHHAAlarm	BOOL		ChxStatus.0 ChxData > ChxHHAAlarmLimit. If process alarms are configured to latch by setting ChxConfig.ProcessAlarmLatch this bit remains set even after the condition returns to normal, until reset via explicit CIP message. This message can be sent from the Studio 5000 Module Properties Alarm dialog box or from the Logix controller via MSG instruction.
ChxLLAlarm	BOOL		ChxStatus.1 ChxData < ChxLLAlarmLimit If ChxConfig.ProcessAlarmLatch is set, this alarm remains set until it is unlatched.
ChxHAlarm	BOOL		ChxStatus.2 ChxData > ChxHAlarmLimit If ChxConfig.ProcessAlarmLatch is set, this alarm remains set until it is unlatched
ChxLAlarm	BOOL		ChxStatus.3 ChxData < ChxLAlarmLimit If ChxConfig.ProcessAlarmLatch is set, this alarm remains set until it is unlatched.
ChxRateAlarm	BOOL		ChxStatus.4 ChxData changing faster than ChxRateAlarmLimit. Both positive and negative changes can cause this alarm. If ChxConfig.RateAlarmLatch is set, this alarm remains set until it is unlatched.
ChxOverrange	BOOL		ChxStatus.5 Analog signal is greater than or equal to the maximum detectable signal. Because the signal cannot be measured, it can be significantly above the maximum value.
ChxUnderrange	BOOL		ChxStatus.6 Analog signal is less than or equal to the minimum detectable signal. Because the signal cannot be measured, it can be significantly below the minimum value.
ChxCalFault	BOOL		ChxStatus.7 Set if an error occurs during calibration for Channel x, which causes a bad calibration. Also sets CalFault.

Table 13 - 1756-IF8H Input Tags - Analog and HART PV (AB:1756_IF8H_HARTPV:I:1)

Member Name	Type	Style	Description
ChxData	REAL	Float	Value of analog signal on Channel <i>x</i> after conversion to engineering units.
CSTimestamp	DINT[2]	Hex	Timestamp that is taken at the time the input data was sampled in terms of coordinated system time, which is a 64-bit value in microseconds coordinated across the modules in the 1756 backplane.
RollingTimestamp	INT	Decimal	Timestamp that is taken at the time the input data was sampled in millisecond resolution.
HART	AB:1756_IF8H_HARTData:I:1, Contains HART field device health and dynamic process variables.		
ChxDeviceStatus	AB:1756_IF8H_HARTStatus_Struct:I:1, Channel <i>x</i> HART Device status info.		
Init	BOOL		Searching for or Initializing HART device. If this is 0 and Fail is 1, then HART is not enabled on this channel. If both are 1, then 1756-IF8H is sending out HART messages attempting to establish communication with a HART device.
Fail	BOOL		HART communication failure or device not found or HART not enabled. If this bit is 1, none of the other data in the HART part of the input tag are valid. (HART.PVStatus is also set to 0 to indicate this).
MsgReady	BOOL		Pass-through message reply is ready for query service.
CurrentFault	BOOL		Analog current measurement does not match the current the field device reported over the HART network.
ConfigurationChanged	BOOL		The field device configuration has changed and new field device configuration information can be obtained from the 1756-IF8H module via CIP MSG GetDeviceInfo, which clears this bit.
ResponseCode	SINT	Binary	HART communication status byte or Response code from a recent HART reply. See Response Code and Field Device Status on page 229 for more information.
FieldDeviceStatus	SINT	Binary	HART device status byte from a recent HART reply. Indicates the health of the HART field device. See Field Device Status Bit Mask Definitions on page 230 for more information.
PVOutOfLimits	BOOL	Decimal	The primary variable is beyond its operating limit.
VariableOutOfLimits	BOOL	Decimal	A device variable that is not mapped to the PV is beyond its operating limits.
CurrentSaturated	BOOL	Decimal	The loop current has reached its upper or lower endpoint limit and cannot increase or decrease any further.
CurrentFixed	BOOL	Decimal	The loop current is being held at a fixed value and is not responding to process variations.
MoreStatus	BOOL	Decimal	More status information is available via command 48, 'Read Additional Status' information.
ColdStart	BOOL	Decimal	A power failure or device reset occurred.
Changed	BOOL	Decimal	An operation was performed that changed the configuration of the device.
Malfunction	BOOL	Decimal	The device detected a serious error or failure that compromises device operation.
ExtDeviceStatus	SINT	Binary	Extended device status (from HART cmd9)
Maintenance Required	BOOL	Decimal	Maintenance is needed.
DeviceVariableAlert	BOOL	Decimal	Device reports a problem with some measurement.
PowerLow	BOOL	Decimal	Low power.
ChxPV	REAL	Float	Channel <i>x</i> HART PV value.
ChxSV	REAL	Float	Channel <i>x</i> HART SV value.
ChxTV	REAL	Float	Channel <i>x</i> HART TV value.
ChxFV	REAL	Float	Channel <i>x</i> HART FV value.
ChxPVStatus	SINT	Hex	Channel <i>x</i> HART PV status, see HART PV, SV, TV, and FV Status on page 236 for more information.
ChxSVStatus	SINT	Hex	Channel <i>x</i> HART SV status, see HART PV, SV, TV, and FV Status on page 236 for more information.
ChxTVStatus	SINT	Hex	Channel <i>x</i> HART TV status, see HART PV, SV, TV, and FV Status on page 236 for more information.
ChxFVStatus	SINT	Hex	Channel <i>x</i> HART FV status, see HART PV, SV, TV, and FV Status on page 236 for more information.

Analog and HART by Channel

Table 14 - 1756-IF8H Input Tags - Analog and HART by Channel (AB:1756-IF8H_AnalogHARTbyChannel:I:0)

Member Name	Type	Style	Description
ChannelFaults	INT	Binary	Indicates a problem with analog data on Channel <i>x</i> or broken communication between the Logix controller and the 1756-IF8H module (bits 0...15) Example: Set if analog signal is larger than 20 mA.
ChxFault	BOOL	Decimal	ChannelFaults. <i>x</i>
ModuleFaults	SINT	Binary	Module level fault status (bits 0...7)
CalFault	BOOL	Decimal	(ModuleFaults.1) 1756-IF8H module calibration failed.
Calibrating	BOOL	Decimal	(ModuleFaults.2) Calibration in progress.
UpdatedStatusReady	BOOL	Decimal	(ModuleFaults.3) Module has collected updated Additional Device Status from HART command 48. This status can be retrieved by using the Read Additional Status service, 16#4C. For more information about this service, see Read Additional Status (Service Code = 16#4C) on page 181 .
AnalogGroupFault	BOOL	Decimal	(ModuleFaults.7) Indicates that a fault has occurred on any channel (any of ChannelFaults).
Chx (Ch0...Ch7)	AB:1756_IF8H_HARTDataAll_Struct:I:0, Channel 0 analog and HART data.		
Data	REAL	Float	Analog value in engineering units.
DeviceStatus	AB:1756_IF8H_HARTStatusAll_Struct:I:0, Channel 0 HART Device status info.		
HARTInit	BOOL	Decimal	Searching for or Initializing HART device. If this is 0 and Fail is 1, then HART is not Enabled on this channel. If both are 1, then 1756-IF8H is sending out HART messages attempting to establish communication with a HART device.
HARTCommFail	BOOL	Decimal	HART communication failure or device not found or HART not enabled. If this bit is 1, none of the other data in the HART part of the Input Tag are valid. (HART.PVStatus is also set to 0 to indicate this)
MsgReady	BOOL	Decimal	Pass-through message reply is ready for query service.
CurrentFault	BOOL	Decimal	Analog current measurement does not match the current the Field Device reported over the HART network.
ConfigurationChanged	BOOL	Decimal	The field device configuration has changed and new field device configuration information can be obtained from the 1756-IF8H module via CIP MSG GetDeviceInfo, which clears this bit.
BrokenWire	BOOL	Decimal	Indicates that current is not flowing through the module as expected. Broken wiring, RTB removal, or a powered-off field device can cause this.
HARTFault	BOOL	Decimal	Indicates a problem with HART data from the field device on Channel <i>x</i> . Examples are HART not enabled, HART device not connected, HART communication failure due to noise. These Field Device Status conditions also cause this to be set: Device Malfunction, PV Out of Limits, Loop Current Saturated, and Loop Current Fixed.
ResponseCode	SINT	Binary	HART communication status byte or Response code from a recent HART reply. See Response Codes and Field Device Status on page 229 for more information.
FieldDeviceStatus	SINT	Binary	HART device status byte from a recent HART reply. Indicates the health of the HART Field device. See Field Device Status Bit Mask Definitions on page 230 for more information.
PVOutOfLimits	BOOL	Decimal	The primary variable is beyond its operating limit.
VariableOutOfLimits	BOOL	Decimal	A device variable that is not mapped to the PV is beyond its operating limits.
CurrentSaturated	BOOL	Decimal	The loop current has reached its upper or lower endpoint limit and cannot increase or decrease any further.
CurrentFixed	BOOL	Decimal	The loop current is being held at a fixed value and is not responding to process variations.
MoreStatus	BOOL	Decimal	More status information is available via command 48, 'Read Additional Status' information.
ColdStart	BOOL	Decimal	A power failure or device reset occurred.
Changed	BOOL	Decimal	An operation was performed that changed the configuration of the device.
Malfunction	BOOL	Decimal	The device detected a serious error or failure that compromises device operation.
AlarmStatus	SINT	Binary	Indicates various alarms on the analog signal. Also sets Ch0Fault for Overrange, Underrange, and CalFault.

Table 14 - 1756-IF8H Input Tags - Analog and HART by Channel (AB:1756-IF8H_AnalogHARTbyChannel:I:0)

Member Name	Type	Style	Description
HHAlarm	BOOL	Decimal	(AlarmStatus.0) If process alarms are configured to latch by setting Ch0Config.ProcessAlarmLatch this bit remains set even after the condition returns to normal, until reset via explicit CIP message. This message can be sent from the Studio 5000 Module Properties Alarm dialog box or from the Logix controller via MSG instruction.
LLAlarm	BOOL	Decimal	(AlarmStatus.1) If Ch0Config.ProcessAlarmLatch is set, this alarm remains set until it is unlatched.
HAlarm	BOOL	Decimal	(AlarmStatus.2) If Ch0Config.ProcessAlarmLatch is set, this alarm remains set until it is unlatched
LAlarm	BOOL	Decimal	(AlarmStatus.3) If Ch0Config.ProcessAlarmLatch is set, this alarm remains set until it is unlatched.
RateAlarm	BOOL	Decimal	(AlarmStatus.4) Ch0Data changing faster than Ch0RateAlarmLimit. Both positive and negative changes can cause this alarm. If Ch0Config.RateAlarmLatch is set, this alarm remains set until it is unlatched.
Overrange	BOOL	Decimal	(AlarmStatus.5) Analog signal is greater than or equal to the maximum detectable signal. Because the signal cannot be measured, it can be significantly above the maximum value.
Underrange	BOOL	Decimal	(AlarmStatus.6) Analog signal is less than or equal to the minimum detectable signal. Because the signal cannot be measured, it can be significantly below the minimum value.
CalFault	BOOL	Decimal	(AlarmStatus.7) Set if an error occurs during calibration for Channel <i>x</i> , which causes a bad calibration. Also sets CalFault.
ExtDeviceStatus	SINT	Binary	Extended device status (from HART cmd9)
Maintenance Required	BOOL	Decimal	Maintenance is needed.
DeviceVariableAlert	BOOL	Decimal	Device reports a problem with some measurement.
PowerLow	BOOL	Decimal	Low power.
PV	REAL	Float	Primary value. This value is the same value as signaled on the analog channel and is the most important measurement that is made by this device.
SV	REAL	Float	Secondary value.
TV	REAL	Float	Third value.
FV	REAL	Float	Fourth value.
PVStatus	SINT	Hex	Primary status. 16#C0 = Connected. 16#00 = Not Connected.
SVStatus	SINT	Hex	Secondary status. 16#C0 = Connected. 16#00 = Not Connected.
TVStatus	SINT	Hex	Third status 16#C0 = Connected. 16#00 = Not Connected.
FVStatus	SINT	Hex	Fourth status. 16#C0 = Connected. 16#00 = Not Connected.
CSTimestamp	DINT[2]	Hex	Timestamp that is taken at the time the input data was sampled in terms of coordinated system time, which is a 64-bit value in microseconds coordinated across the modules in the 1756 backplane.
RollingTimestamp	INT	Decimal	Timestamp that is taken at the time the input data was sampled in millisecond resolution.

1756-IF8IH HART Isolated Analog Input Module

Topic	Page
Module Features	53
Wire the Module	61
Circuit Diagram	61
1756-IF8IH Module Fault and Status Reporting	62
Module Calibration	64
Module-defined Data Types, 1756-IF8IH Module	65

Module Features

The 1756-IF8IH module is an isolated, 8-channel, current-only input module capable of HART communication on all channels. Each channel is individually configurable.

The 1756-IF8IH module has the following features:

- Eight isolated, individually configurable input channels with a separate HART modem on each channel
- Channel-to-channel, channel-to-backplane, and channel-to-frame ground galvanic isolation at a continuous level of 250V AC rms
- Two input ranges: 0...20 mA and 4...20 mA
- Choice of four data formats:
 - Analog Only
 - Analog and HART PV
 - Analog and HART by channel with Configure HART Device = No
 - Analog and HART by channel with Configure HART Device = Yes
- Supports full simultaneous HART 1200 baud bandwidth to all channels
- Channel ADC filter (one setting per module)
- Digital filtering (configurable per channel)
- Real-time sampling
- Auto-scanning of HART variables (PV, SV, TV, FV)
- HART pass-through interface
- Option to configure a HART device with user-supplied data. You can configure PV damping value, PV range values, PV transfer function, and PV units code. This option is available only when the data format is Analog and HART by Channel with Configure HART device = Yes
- User scaling of input data

- Time stamping
- Alarms and fault detection
 - Open wire detection(4...20 mA range)
 - Underrange and overrange detection
 - Fault reporting
 - Process and Rate alarms and alarm latching (only if Configure HART Device = No)
 - Status indicator information
- User Calibration via CIP messaging
- Calibration via output word (available only when the data format is Analog and HART by Channel with Configure HART Device = Yes)
- Downloadable firmware using ControlFlash™
- Add-on Profile
- “Bumpless” configuration for a smooth transition in new configurations.
- Removal and insertion under power (RIUP)

HART Compatibility

The 1756-IF8IH functions as a HART master. It communicates with HART devices that have a HART revision of 5, 6, or 7. Each channel has its own HART modem and functions as a HART primary master.

The 1756-IF8IH module supports one HART device per channel.

The 1756-IF8IH module does not support burst mode, phase shift keying (PSK), or multi-drop network configuration. The module detects and turns off a bursting device at initial connection with the device.

HART Handheld Configurator

A HART handheld configuration tool can be connected to the HART device while the module is connected as long as the configuration tool is the secondary master.

Data Formats

Data format determines which values are included in the input tag of the module and the features that are available to your application. Select the data format on the General tab in the Studio 5000 Logix Designer® application.

[Table 15](#) shows the available data formats for the 1756-IF8IH module.

Table 15 - Data Formats for the 1756-IF8IH Module

Format	Description						
	Analog signal values	Analog status	HART process variables and device health	Grouped HART and analog data for each channel	Configure HART device data	Process Alarms with latching	Rate Alarm
Analog Only	X	X				X	X
Analog and HART PV	X	X	X			X	X
Analog and HART by Channel, Configure HART Device = No	X	X	X	X		X	X
Analog and HART by Channel, Configure HART Device = Yes	X	X	X	X	X		

Choose Analog and HART PV if you prefer the analog values for all channels to be grouped near the end of the tag. This format makes it easy to view all eight analog values at once.

Choose Analog and HART by Channel if you prefer Status, Analog Value, and Device Status for each channel to be together in the tag. This format makes it easier to view all data for one field device.

Input Ranges

You can select one of two input ranges for each channel on the module. The range designates the minimum and maximum signals that are detectable by the module. These are the possible ranges:

- 0...20 mA
- 4...20 mA (HART instruments use this range.)

Module Filter

Each channel has an ADC filter that affects 50 Hz and 60 Hz rejection, noise, accuracy, and the minimum sample time (RTS). The module filter attenuates the input signal at the specified frequency and above.

The module attenuates the selected frequency by approximately -3 dB or 0.707 of the applied amplitude. An input signal with frequencies above the selected frequency is attenuated more while frequencies below the selection receive no attenuation.

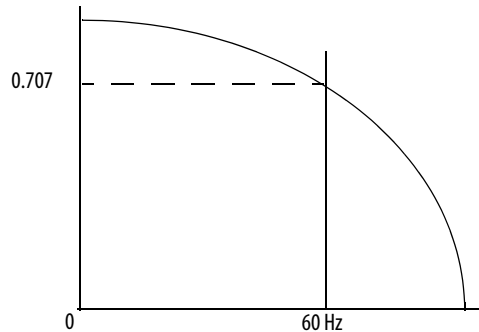

A by-product of the filter selection is the minimum available sample rate (RTS). For example, the 1000 Hz selection does not attenuate frequencies less than 1104 Hz, but allows all 8 channels to be sampled within 15 ms. The 10 Hz selection attenuates all frequencies above 2.2 Hz but only allows all 8 channels to be sampled within 488 ms.

IMPORTANT 60 Hz is the default setting for the module filter. Do not use the 1000 Hz module filter with HART instruments.

There is one filter setting that is applied globally to all channels. Use [Table 16](#) to help choose a filter setting.

Table 16 - Module Filter Selections with Associated Performance Data for 1756-IF8IH

Module Filter Setting (-3 dB)	10 Hz	15 Hz	20 Hz	50 Hz	60 Hz	100 Hz	250 Hz	1000 Hz
Minimum Sample Time (RTS ms)	488	328	275	115	115	61	25	15
Effective Resolution (0...20 mA, 4...20 mA range)	18 bits	18 bits	18 bits	17 bits	17 bits	16 bits	16 bits	15 bits
	0.08 μA	0.08 μA	0.08 μA	0.16 μA	0.16 μA	0.32 μA	0.32 μA	0.64 μA
-3 dB Frequency	2.2 Hz	11.5 Hz	13.8 Hz	34.5 Hz	34.5 Hz	69.0 Hz	221 Hz	1104 Hz
50 Hz Common Rejection	100 dB	100 dB						
50 Hz Normal Rejection	95 dB	74 dB						
60 Hz Normal Rejection	95 dB	74 dB	97 dB					
60 Hz Common Rejection	100 dB	100 dB	100 dB					
Channel ADC Update Rate (samples per second)	30 SPS	50 SPS	60 SPS	150 SPS	150 SPS	300 SPS	960 SPS	4800 SPS
Settling Time	100 ms	80 ms	66.7 ms	26.7 ms	26.7 ms	13.3 ms	4.17 ms	0.83 ms

Digital Filter

The digital filter smooths input data noise transients. There is a separate digital filter for each channel.

The digital filter value specifies the time constant in milliseconds for a digital first order lag filter on the input. A value of 0 disables the filter.

The digital filter equation is a classic first order lag equation:

$$Y_n = Y_{n-1} + \frac{[\Delta t]}{\Delta t + T_A} (X_n - Y_{n-1})$$

Y_n = present output, filtered peak voltage (PV)

Y_{n-1} = previous output, filtered PV

Δt = module channel update time (seconds)

T_A = digital filter time constant (seconds)

X_n = present input, unfiltered PV

[Figure 11](#) illustrates filter response to a step input. When the digital filter time constant elapses, 63.2% of the total response is reached. Each additional time constant achieves 63.2% of the remaining response.

Figure 11 - Filter Response

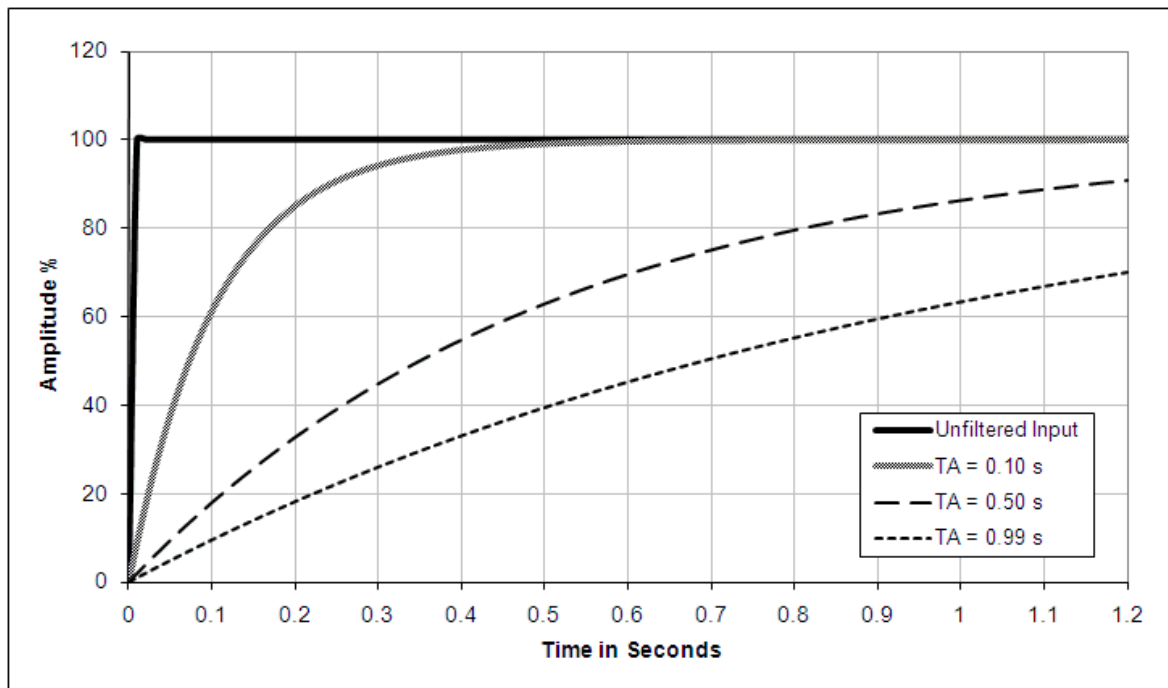

Real-time Sampling

This parameter instructs the module how often to scan its input channels and obtain new sampled data. After the channels are scanned, the module broadcasts that data (multicast or unicast) to the local chassis backplane. This feature is applied on a module-wide basis.

During module configuration, you specify a real-time sampling (RTS) period and a requested packet interval (RPI). Both of these features instruct the module to broadcast data, but only the RTS feature instructs the module to scan its channels before broadcasting.

For more RTS information, see [Real Time Sample \(RTS\) on page 23](#).

Underrange and Overrange Detection

The module detects when it is operating beyond limits of the input range. This status indication tells you that the input signal is not being measured accurately because the signal is beyond the measuring capability of the module. For example, the module cannot distinguish 20.58...30 mA.

[Table 17](#) shows the input ranges of the 1756-IF8IH module and the lowest and highest signal available in each range before the module detects an underrange and overrange condition.

Table 17 - Low and High Signal Limits on the 1756-IF8IH Module

Input Module	Available Range	Lowest Signal in Range	Highest Signal in Range
1756-IF8IH	0...20 mA	0 mA	20.58 mA
	4...20 mA	3.42 mA	20.58 mA

Open Circuit Detection

In the 4...20 mA range, if the signal wire to a channel opens, the module reports a negative full-scale value in the input data tag of the channel within 5 seconds. The module also sets the ChxBrokenWire status bit.

In the 0...20 mA range, an open-circuit condition results in a measured value of 0 mA, which is the same as a measured value of 0 mA when there is not an open-circuit condition. The appropriate Underrange bit is set but the ChxBrokenWire bit is not set.

Auto-Configure HART Device

The Auto-Configure HART device feature automatically configures a HART device with certain user-supplied values. Configurable values are PV Damping, PV Range, PV Range Units Code, and PV Transfer Function. You specify the configuration values in the Logix Designer application. One checkbox enables the PV damping value configuration and another enables configuration of PV range, PV transfer function, and PV units. The specified values are sent to the device at device connection time or if the module detects that the device configuration bit is set. See [HART Command Tab - 1756-IF8IH, 1756-OF8IH on page 169](#).

The specified values are sent to the device only if the feature is enabled and the module detects that the values in the device are not within 1% of the values in the configuration tag. If the PV Range enable bit is set and the module detects that the device PV Units Code does not match the value in the configuration tag, the module sends the PV Units Code to the module. The PV Damping, PV units code, PV Upper and Lower Range values, and PV Transfer Function reside in the configuration table. If the write operation fails (for example, device write protected or unsupported values) then a status flag is set to indicate that the device is not configured properly. If the write is successful, the module verifies that the PV Range and Damping values that are read from the device are within 1.0% of the values in the configuration tag. If they are not, an error is flagged.

The valid range of HART configuration values depends on the HART device that is connected to the module. The Logix Designer application does not check that the values that are entered in the HART Command tab are appropriate. Confirm on your own that valid values for your HART devices are used.

Rate Alarm

This feature is not available if Configure HART Device = Yes.

The value for the Rate Alarm Limit is entered in scaled engineering units per second. The rate alarm triggers if the rate of change between input samples for a channel exceeds the specified rate-alarm trigger point for that channel. Rate Alarm uses the signal value after filtering by the Module Filter and before the Digital Filter is applied.

Process Alarms

This feature is not available if Configure HART Device = Yes.

This feature enables you to specify alarm limits for input level and have the module report when those levels have been exceeded. It is available only if Configure HART Device = No. In module configuration, you specify values for high-high, high, low, and low-low limits. Process alarms can be latched.

Only status bits in the input table are affected during runtime after a valid configuration; no fault bit is set.

AlarmDeadband determines when the AlarmLimit bits are cleared. Once the bit is set by exceeding the AlarmLimit, it cannot be cleared until the input has passed the deadband delta from the AlarmLimit value. For example, if the deadband is 0.5 and the HAlarmLimit is 10.0, the HAlarm status bit is not cleared until the input is 9.5 or less. Likewise, if the LAlarmLimit is 1.0, the associated LAlarm bit would clear when the input is 1.5 or more for the same deadband value.

Alarm bits are cleared when the input falls inside the specified Alarm Limit. The exception is when ProcessAlarmLatch is set in the configuration. In that case, clearing alarm bits requires the command 'Unlatch Alarm Status' be issued to all alarms or individual alarms.

For more information, see [Process Alarms on page 38](#).

Wire the Module

Figure 12 shows module wiring information. We recommend using a separate power supply for each input to help maintain isolation.

Figure 12 - 1756-IF8IH Wiring Diagram

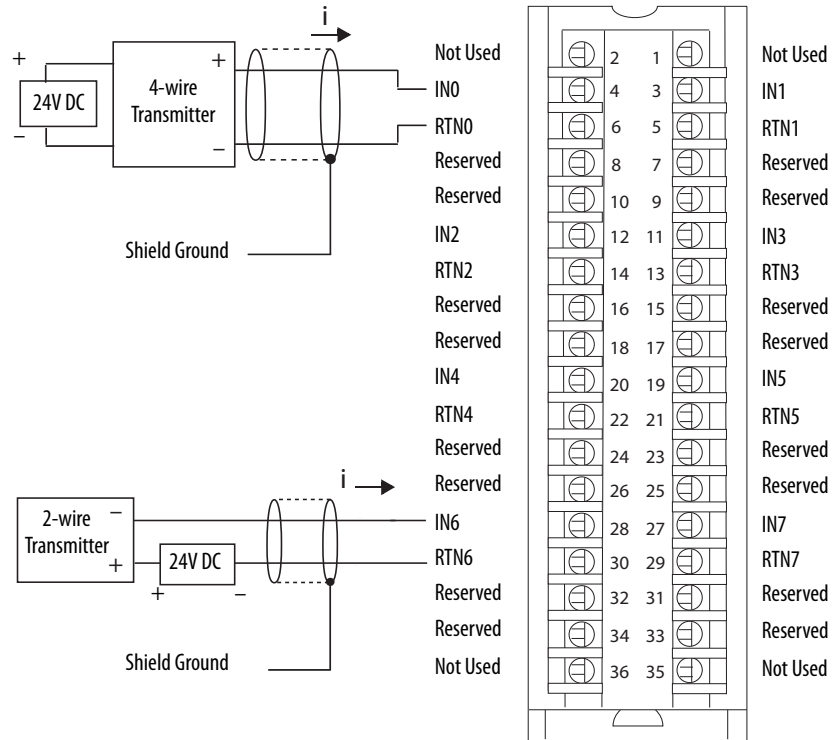

Circuit Diagram

Figure 13 is a simplified diagram of the input circuit that is used in the 1756-IF8IH module.

Figure 13 - 1756-IF8IH Simplified Input Circuit

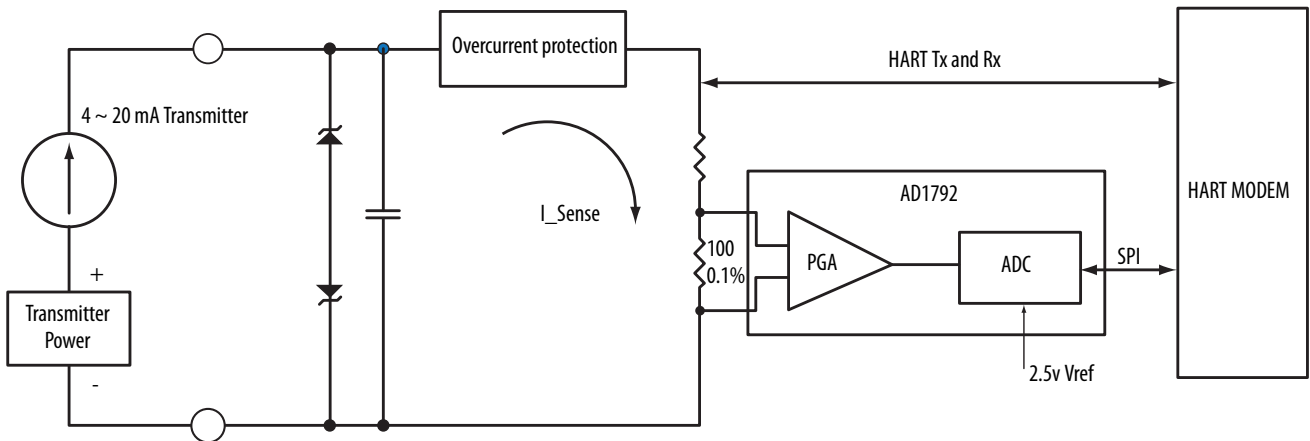

1756-IF8IH Module Fault and Status Reporting

The 1756-IF8IH module multicasts status/fault data to the controller with its channel data. The fault data is arranged to let you choose the level of granularity you desire for examining fault conditions. Three levels of tags work together to provide an increasing degree of detail about the cause of faults on the module. [Figure 14](#) offers an overview of how faults are reported.

Figure 14 - 1756-IF8IH Module Fault Reporting

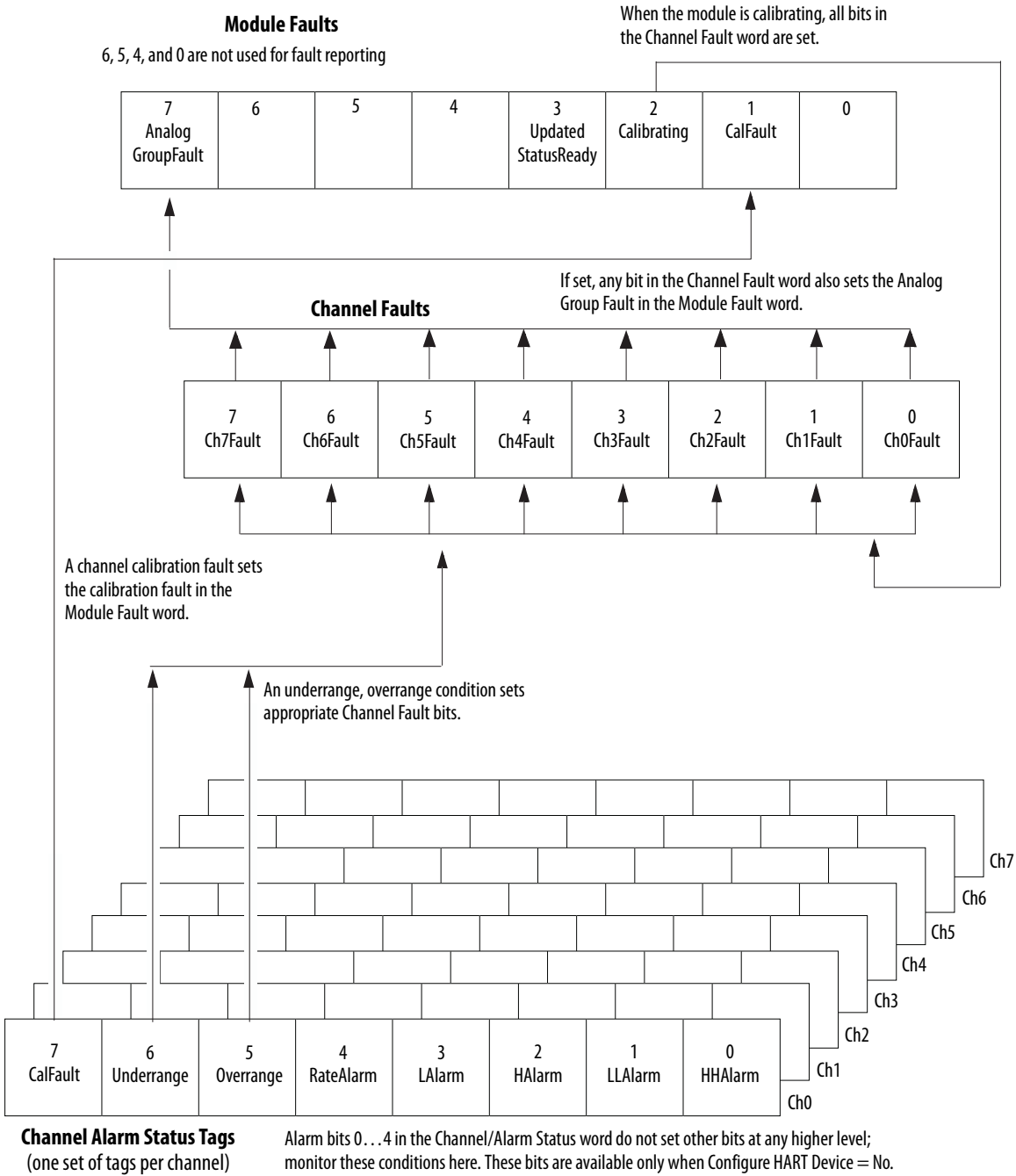

[Table 18](#) lists tags you can examine in ladder logic to indicate when a fault has occurred.

Table 18 - 1756-IF8IH Tags That Can Be Examined in Ladder Logic

Tag	Description	Tag Name Analog and HART PV	Tag Name Analog and HART by Channel ⁽¹⁾
Module Fault Word	This word provides fault summary reporting.	ModuleFaults	ModuleFaults
Channel Fault Word	This word provides underrange, overrange, and communication fault reporting.	ChannelFaults ChxFault	ChannelFaults ChxFault
Channel Status Word	These words provide individual channel underrange and overrange fault indications and reporting for process alarms, rate alarms, and calibration faults.	ChxStatus	Chx.DeviceStatus.AlarmStatus
HART Faults	These bits provide HART communication status.	HARTFaults	Chx.DeviceStatus.HARTFault
HART Device Status	This data reports HART field device health.	HART.ChxDevice Status	Chx.DeviceStatus.FieldDeviceStatus

(1) Available only for 1756-IF8H firmware revision 2.001.

1756-IF8IH Module Fault Word Bits

Bits in this word provide the highest level of fault detection. A nonzero condition in this word reveals that a fault exists on the module. You can examine further to isolate the fault. [Table 19](#) lists tags that can be examined in ladder logic to indicate when a fault has occurred.

Table 19 - 1756-IF8IH Tags That Can Be Examined in Ladder Logic

Tag	Description
Analog Group Fault	This bit is set when any bits in the Channel Fault word are set. Its tag name is AnalogGroupFault.
Calibrating	This bit is set when any channel is being calibrated. When this bit is set, all bits in the Channel Fault word are set. Its tag name is Calibrating.
Calibration Fault	This bit is set when any of the individual Channel Calibration Fault bits are set. Its tag name is CalFault.

1756-IF8IH Channel Fault Tags

During normal module operation, bits in the Channel Fault word are set if any of the respective channels has an Underrange or Overrange condition. Examine this word for a nonzero value to check for Underrange or Overrange conditions on the module.

[Table 20](#) lists conditions that set **all** Channel Fault word bits.

Table 20 - 1756-IF8IH Conditions That Set All Channel Fault Word Bits

This Condition Sets All Channel Fault Word Bits	And Causes the Module to Display the Following in the Channel Fault Word Bits
A channel is being calibrated	16#00FF
A communication fault occurred between the module and its owner-controller	16#FFFF

Module Calibration

There are two ways to initiate calibration of the 1756-IF8IH module:

- Logix Designer application Calibration tab
- Module Output Word

Module Calibration Via Logix Designer Application

The Calibration tab in the Logix Designer application provides a button to initiate module calibration and a display of the results. Refer to [Calibration Tab on page 170](#) for more information.

Module Calibration Via Output Word

The 1756-IF8IH module allows you to perform calibration by setting and clearing bits in the module output word. This method of calibration is available only when Configure HART Device = Yes. The module must be connected to a controller and the controller must be in run mode.

See [Table 28 on page 74](#) for descriptions of the tags in the 1756-IF8IH output word.

To perform a module calibration via the output word, set and clear bits in sequence to perform the calibration tasks. This table shows 1756-IF8IH calibration bits.

Step	Output Word Bit	Description
Set the calibration date	CalibrationDate	The date that you want to be associated with this calibration; typically the current date. Set the date before starting the calibration.
Initiate calibration	ChxCalibrate	Set this bit to initiate calibration, and keep it set until the calibration sequence is complete. If this bit clears before the calibration is complete, the calibration is aborted.
Perform low calibration	ChxCalLowRef	Perform low calibration at the low reference point (0.5 mA). Connect a valid low reference signal before setting this bit.
Perform high calibration	ChxCalHighRef	Perform high calibration at the high reference point (20 mA). Connect a valid high reference signal before setting this bit.
Abort calibration	ChxCalibrate ChxCalLowRef ChxCalHighRef	Setting all three calibration bits aborts a calibration.

■ Module-defined Data Types, 1756-IF8IH Module

[Table 21](#) ... [Table 28](#) describe module-defined data types for the 1756-IF8IH module and include information for configuration and input tags.

Available tags depend on the selected input data format, as shown in [Table 21](#).

Table 21 - 1756-IF8IH Input Data Choice and Tags

Input Data Choice	Tag	Main Module Defined Type	Subtype Used by Main Type
Analog Only	Configuration	AB:1756_IF8IH:C:0	AB:1756_IF8IH_ChConfig_Struct:C:0
	Input	AB:1756_IF8IH_Analog:I:0	None
Analog and HART PV	Configuration	AB:1756_IF8IH:C:0	AB:1756_IF8IH_ChConfig_Struct:C:0
	Input	AB:1756_IF8IH_HARTPV:I:1	AB:1756_IF8IH_HARTData:I:1 AB:1756_IF8IH_HARTStatus_Struct:I:1
Analog and HART by Channel Configure HART Device = No	Configuration	AB:1756_IF8IH:C:0	AB:1756_IF8IH_ChConfig_Struct:C:0
	Input	AB:1756_IF8IH_AnalogHARTbyChannel:I:0	AB:1756_IF8IH_HARTDataAll_1_Struct:I:0 AB:1756_IF8IH_HARTStatusAll_1_Struct:I:0
Analog and HART by Channel Configure HART Device = Yes	Configuration	AB:1756_IF8IH_HART_CMD:C:0	AB:1756_IF8IH_HART_ChConfig_Struct:C:0
	Input	AB:1756_IF8IH_AnalogHARTbyChannel_1:I:0	AB:1756_IF8IH_HARTDataAll_1_Struct:I:0 AB:1756_IF8IH_HARTStatusAll_1_Struct:I:0
	Output	AB:1756_IF8IH:O:0	None

Configuration - Configure HART Device = No

[Table 22](#) lists the configuration tags for the 1756-IF8IH module when Configure HART Device is set to No.

Table 22 - 1756-IF8IH Configuration Tags, Configure HART Device = No (AB:1756_IF8IH_HART_CMD:C:0)

Member Name	Type	Style	Description
ModuleFilter	SINT	Decimal	See the Module Filter Selections with Associated Performance Data for 1756-IF8IH table on page 56 . 0...10 Hz, 1...50 Hz, 2...60 Hz, 3...100 Hz, 4...250 Hz, 5...1000 Hz, 6...20 Hz, 7 = 15 Hz. 100 Hz is invalid if HART is enabled.
RealTimeSample	INT	Decimal	Milliseconds between reading signal values. See Real-time Sampling on page 36 for more information.
ChxConfig (Ch 0...Ch7)	AB:1756_IF8IH_ChConfig_Struct:C:0		
Config	SINT	Binary	
RateAlarmLatch	BOOL	Decimal	(Config.4) After a Rate Alarm is detected, keep I.ChxRateAlarm set even after Rate returns to normal, until unlatched by CIP Service Message.
ProcessAlarmLatch	BOOL	Decimal	(Config.5) After a Process Alarm such as LL is detected, keep I.ChxLLAlarm set even after measurement returns to normal, until unlatched by CIP Service Message.
AlarmDisable	BOOL	Decimal	(Config.6) Do not report Process or Rate Alarms.
HARTEn	BOOL	Decimal	(Config.7) Enable HART communication. Must be 1 for valid HART data in Input Tag and Asset Management access to HART Field Device.
RangeType	SINT	Decimal	0 = invalid, 1 = invalid, 2 = invalid, 3 = 0...20 mA, 4 = 4...20 mA
DigitalFilter	INT	Decimal	Time Constant of low pass filter in ms. See Digital Filter on page 57 for more information.
RateAlarmLimit	REAL	Float	Maximum Ramp Rate value to trigger a Rate Alarm when the Input Signal rate of change exceeds the setpoint. See Scaling to Engineering Units on page 153 for more information.
LowSignal	REAL	Float	Lower current value for scaling to engineering units. Default is 4 mA. Must be less than HighSignal and more than or equal to the minimum Input Range. See Scaling to Engineering Units on page 153 for more information.

Table 22 - 1756-IF8IH Configuration Tags, Configure HART Device = No (AB:1756_IF8IH_HART_CMD:C:0)

Member Name	Type	Style	Description
HighSignal	REAL	Float	Upper current value for scaling to engineering units. Default is 20 mA. Must be more than LowSignal and less than or equal to the maximum Input Range. See Scaling to Engineering Units on page 153 for more information.
LowEngineering	REAL	Float	Measured quantity in engineering units that results in a signal level equal to LowSignal. See Scaling to Engineering Units on page 153 for more information.
HighEngineering	REAL	Float	Measured quantity in engineering units that results in a signal level equal to HighSignal. See Scaling to Engineering Units on page 153 for more information.
LAlarmLimit	REAL	Float	PV Lower Range value.
HAlarmLimit	REAL	Float	PV Upper Range value.
LLAlarmLimit	SINT	Decimal	PV Range Units Code.
HHAlarmLimit	SINT	Decimal	PV Transfer Function (see HART spec).
AlarmDeadBand	REAL	Float	Specifies the deadband range for the alarm trigger point. See Figure 3 on page 38 for an illustration.
CalBias	REAL	Float	Sensor Offset in engineering units added to the measured signal before reporting Ch0.Data.
PassthroughHandleTimeOut	INT	Decimal	Response hold time in milliseconds.
PassthroughFreq_14	BOOL	Decimal	Selects the policy for sending HART pass-through messages. See Pass-through Setting, Ratio, and Priority (Input Modules) on page 156
PassthroughFreq_15	BOOL	Decimal	

Configuration - Configure HART Device = Yes

[Table 23](#) lists the configuration tags for the 1756-IF8IH module when Configure HART Device is set to Yes.

Table 23 - 1756-IF8IH Configuration Tags (AB:1756_IF8IH_HART_CMD:C:0)

Member Name	Type	Style	Description
ModuleFilter	SINT	Decimal	See the Module Filter Selections with Associated Performance Data for 1756-IF8IH table on page 56 . 0... 10 Hz, 1... 50 Hz, 2... 60 Hz, 3... 100 Hz, 4... 250 Hz, 5... 1000 Hz, 6... 20 Hz, 7 = 15 Hz. 100 Hz is invalid if HART is enabled.
RealTimeSample	INT	Decimal	Milliseconds between reading signal values. See Real-time Sampling on page 58 for more information.
ChxConfig (Ch 0...Ch7)	AB:1756_IF8IH_HART_ChConfig_Struct:C:0		
Config	SINT	Binary	
PVDampingConfigEn	BOOL	Decimal	(Config.0) Enable HART PV damping auto-configuration.
PVRangeConfigEn	BOOL	Decimal	(Config.1) Enable HART PV range auto-configuration.
HARTEn	BOOL	Decimal	(Config.7) Enable HART communication. Must be 1 for valid HART data in Input Tag and Asset Management access to HART Field Device.
RangeType	SINT	Decimal	3 = 0...20 mA, 4 = 4...20 mA (0, 1, and 2 are invalid).
DigitalFilter	INT	Decimal	Time Constant of low pass filter in ms. See Digital Filter on page 57 for more information.
PVDamping ⁽¹⁾	REAL	Float	PV Damping Value (HART Command 35, in seconds).
LowSignal	REAL	Float	Lower current value for scaling to engineering units. Default is 4 mA. Must be less than HighSignal and more than or equal to the minimum Input Range. See Scaling to Engineering Units on page 153 for more information.
HighSignal	REAL	Float	Upper current value for scaling to engineering units. Default is 20 mA. Must be more than LowSignal and less than or equal to the maximum Input Range. See Scaling to Engineering Units on page 153 for more information.
LowEngineering	REAL	Float	Measured quantity in engineering units that results in a signal level equal to LowSignal. See Scaling to Engineering Units on page 153 for more information.

Table 23 - 1756-IF8IH Configuration Tags (AB:1756_IF8IH_HART_CMD:C:0)

Member Name	Type	Style	Description
HighEngineering	REAL	Float	Measured quantity in engineering units that results in a signal level equal to HighSignal. See Scaling to Engineering Units on page 153 for more information.
PVLowerRange ⁽¹⁾	REAL	Float	PV Lower Range value (See HART Command Tab - 1756-IF8IH, 1756-OF8IH on page 169).
PVUpperRange ⁽¹⁾	REAL	Float	PV Upper Range value (See HART Command Tab - 1756-IF8IH, 1756-OF8IH on page 169).
PVUnits ⁽¹⁾	SINT	Decimal	PV Range Units Code (See HART Command Tab - 1756-IF8IH, 1756-OF8IH on page 169).
PVTransferFunction ⁽¹⁾	SINT	Decimal	PV Transfer Function (See HART Command Tab - 1756-IF8IH, 1756-OF8IH on page 169).
CalBias	REAL	Float	Sensor Offset in engineering units added to the measured signal before reporting Ch0.Data.
PassthroughHandleTimeOut	INT	Decimal	Response hold time in milliseconds.
PassthroughFreq_14	BOOL	Decimal	Selects the policy for sending HART pass-through messages. See Pass-through Setting, Ratio, and Priority (Input Modules) on page 156 .
PassthroughFreq_15	BOOL	Decimal	

(1) The valid range of HART configuration values depends on the HART device that is connected. The Logix Designer application does not check that the entered values for PVDampingValue, PVLowerRange/PVUpperRange, PVRangeUnitsCode, and PVTransferFunction are valid for the connected device. It is your responsibility to evaluate the entered values.

Input - Analog Only

[Table 24](#) describes the input tags available in the Analog Only data format for the 1756-IF8IH module.

Table 24 - 1756-IF8IH Input Tags - Analog Only (AB:1756_IF8IH_Analog:I:0)

Member Name	Type	Style	Description
ChannelFaults	INT	Binary	Channel fault status bits.
ChxFault (Ch 0...Ch7)	BOOL	Decimal	(ChannelFaults.0...ChannelFaults.7) A fault has occurred on the corresponding channel.
ChxBrokenWire (Ch 0...Ch7)	BOOL	Decimal	(ChannelFaults.8...ChannelFaults.15) Indicates that current is not flowing through the module as expected. Broken wiring, RTB removal, or a powered-off field device can cause this.
HARTFaults	SINT	Binary	HART Fault status bits.
ChxHARTFault (Ch 0...Ch7)	BOOL	Decimal	(HARTFaults.0...HARTFaults.7) Indicates a problem with HART data from the field device on Channel x. Examples are HART not enabled, HART device not connected, HART communication failure due to noise. These field device status conditions also cause this to be set: Device Malfunction, PV Out of Limits, Loop Current Saturated, and Loop Current Fixed.
ModuleFaults	SINT	Binary	Module fault status bits.
CalFault	BOOL	Decimal	(ModuleFaults.1) A calibration fault has occurred on one of the channels.
Calibrating	BOOL	Decimal	(ModuleFaults.2) A calibration is in progress.
AnalogGroupFault	BOOL	Decimal	(ModuleFaults.7) Indicates that a channel fault has occurred.
ChxStatus (Ch 0...Ch7)	SINT	Binary	Status bits for channel x.
ChxHHAAlarm	BOOL	Decimal	(ChxStatus.1) ChxData > ChxHHAAlarmLimit. If Process Alarms are configured to Latch by setting ChxConfig.ProcessAlarmLatch this bit remains set even after the condition returns to normal, until reset via explicit CIP message. This message can be sent from the Studio 5000® Module Properties Alarm dialog box or from the Logix controller via MSG instruction.
ChxLLAlarm	BOOL	Decimal	(ChxStatus.1) ChxData < ChxLLAlarmLimit. If ChxConfig.ProcessAlarmLatch is set, this alarm remains set until it is unlatched.
ChxHALarm	BOOL	Decimal	(ChxStatus.2) ChxData > ChxHALarmLimit. If ChxConfig.ProcessAlarmLatch is set, this alarm remains set until it is unlatched.
ChxLAlarm	BOOL	Decimal	(ChxStatus.3) ChxData < ChxLAlarmLimit. If ChxConfig.ProcessAlarmLatch is set, this alarm remains set until it is unlatched.

Table 24 - 1756-IF8IH Input Tags - Analog Only (AB:1756_IF8IH_Analog:I:0)

Member Name	Type	Style	Description
ChxRateAlarm	BOOL	Decimal	(ChxStatus.4) ChxData changing faster than ChxRateAlarmLimit. Both Positive and Negative changes can cause this alarm. If ChxConfig.RateAlarmLatch is set, this alarm remains set until it is unlatched.
ChxOvrrange	BOOL	Decimal	(ChxStatus.5) Analog signal is greater than or equal to the maximum detectable signal. Because the signal cannot be measured, it can be significantly above the maximum value.
ChxUnderrange	BOOL	Decimal	(Ch0Status.6) Analog signal is less than or equal to the minimum detectable signal. Because the signal cannot be measured, it can be significantly below the minimum value.
ChxCalfault	BOOL	Decimal	(Ch0Status.7) Set if an error occurs during calibration for Channel x, which causes a bad calibration. Also sets CalFault.
ChxData (Ch 0...Ch7)	REAL	Float	Value of analog signal on Channel x after conversion to engineering units.
CSTTimeStamp	DINT (2)	Hex	Timestamp that is taken at the time the input data was sampled in terms of coordinated system time, which is a 64-bit value in microseconds coordinated across the modules in the 1756 backplane.
RollingTimeStamp	INT	Decimal	Timestamp that is taken at the time the input data was sampled in millisecond resolution.

Input - Analog and HART PV

[Table 25](#) describes the input tags available in the Analog and HART PV data format for the 1756-IF8IH module.

Table 25 - 1756-IF8IH Input Tags - Analog and HART PV (AB:1756_IF8IH_HARTPV:I:1)

Member Name	Type	Style	Description
ChannelFaults	INT	Binary	Channel fault status bits.
ChxFault (Ch 0...Ch7)	BOOL	Decimal	(ChannelFaults.0...ChannelFaults.7) A fault has occurred on the corresponding channel.
ChxBrokenWire (Ch 0...Ch7)	BOOL	Decimal	(ChannelFaults.8...ChannelFaults.15) Indicates that current is not flowing through the module as expected. Broken wiring, RTB removal, or a powered-off field device can cause this.
HARTFaults	SINT	Binary	HART Fault status bits.
ChxHARTFault (Ch 0...Ch7)	BOOL	Decimal	(HARTFaults.0...HARTFaults.7) Indicates a problem with HART data from the field device on Channel x. Examples are HART not enabled, HART device not connected, HART communication failure due to noise. These field device status conditions also cause this to be set: Device Malfunction, PV Out of Limits, Loop Current Saturated, and Loop Current Fixed.
ModuleFaults	SINT	Binary	Module fault status bits.
CalFault	BOOL	Decimal	(ModuleFaults.1) A calibration fault has occurred on one of the channels.
Calibrating	BOOL	Decimal	(ModuleFaults.2) A calibration is in progress.
UpdatedStatusReady	BOOL	Decimal	(ModuleFaults.3) Module has collected updated Additional Device Status from HART command 48. This status can be retrieved by using the Read Additional Status service, 16#4C. For more information about this service, see Read Additional Status (Service Code = 16#4C) on page 181 .
AnalogGroupFault	BOOL	Decimal	(ModuleFaults.7) Indicates that a channel fault has occurred.
ChxStatus (Ch 0...Ch7)	SINT	Binary	Status bits for channel x.
ChxHHAAlarm	BOOL	Decimal	(ChxStatus.1) ChxData > ChxHHAAlarmLimit. If Process Alarms are configured to Latch by setting ChxConfig.ProcessAlarmLatch this bit remains set even after the condition returns to normal, until reset via explicit CIP message. This message can be sent from the Studio 5000 Module Properties Alarm dialog box or from the Logix controller via MSG instruction.
ChxLLAlarm	BOOL	Decimal	(ChxStatus.1) ChxData < ChxLLAlarmLimit. If ChxConfig.ProcessAlarmLatch is set, this alarm remains set until it is unlatched.
ChxHAlarm	BOOL	Decimal	(ChxStatus.2) ChxData > ChxHAlarmLimit. If ChxConfig.ProcessAlarmLatch is set, this alarm remains set until it is unlatched.

Table 25 - 1756-IF8IH Input Tags - Analog and HART PV (AB:1756_IF8IH_HARTPV:I:1)

Member Name	Type	Style	Description
ChxLAlarm	BOOL	Decimal	(ChxStatus.3)ChxData < ChxLAlarmLimit. If ChxConfig.ProcessAlarmLatch is set, this alarm remains set until it is unlatched.
ChxRateAlarm	BOOL	Decimal	(ChxStatus.4) ChxData changing faster than ChxRateAlarmLimit. Both Positive and Negative changes can cause this alarm. If ChxConfig.RateAlarmLatch is set, this alarm remains set until it is unlatched.
ChxOvrrange	BOOL	Decimal	(ChxStatus.5) Analog signal is greater than or equal to the maximum detectable signal. Because the signal cannot be measured, it can be significantly above the maximum value.
ChxUnderrange	BOOL	Decimal	(Ch0Status.6) Analog signal is less than or equal to the minimum detectable signal. Because the signal cannot be measured, it can be significantly below the minimum value.
ChxCalFault	BOOL	Decimal	(Ch0Status.7) Set if an error occurs during calibration for Channel x, which causes a bad calibration. Also sets CalFault.
ChxData (Ch 0...Ch7)	REAL	Float	Value of analog signal on Channel x after conversion to engineering units.
CSTimeStamp	DINT (2)	Hex	Timestamp that is taken at the time the input data was sampled in terms of coordinated system time, which is a 64-bit value in microseconds coordinated across the modules in the 1756 backplane.
RollingTimeStamp	INT	Decimal	Timestamp that is taken at the time the input data was sampled in millisecond resolution.
HART	AB:1756_IF8IH_HARTData:I:1		
ChxDeviceStatus (Ch 0...Ch7)	AB:1756_IF8IH_HARTStatus_Struct:I:1		
Init	BOOL	Decimal	Searching for or Initializing HART device. If this value is 0 and Fail is 1, then HART is not enabled on this channel. If both are 1, then 1756-IF8IH is sending out HART messages to attempt to establish communication with a HART device.
Fail	BOOL	Decimal	HART communication failure or device not found or HART not enabled. If this bit is 1, none of the other data in the HART part of the input tag are valid. (HART.PVStatus is also set to 0 to indicate this).
MsgReady	BOOL	Decimal	Pass-through message reply is ready for query service.
CurrentFault	BOOL	Decimal	Analog current measurement does not match the current the field device reported over the HART network.
ConfigurationChanged	BOOL	Decimal	The field device configuration has changed and new field device configuration information can be obtained from the 1756-IF8IH module via CIP MSG GetDeviceInfo, which clears this bit.
ResponseCode	SINT	Binary	HART communication status byte or Response code from a recent HART reply. See Response Code and Field Device Status on page 229 for more information.
FieldDeviceStatus	SINT	Binary	HART device status byte from a recent HART reply. Indicates the health of the HART field device. See Field Device Status Bit Mask Definitions on page 230 for more information.
PVOutOfLimits	BOOL	Decimal	The primary variable is beyond its operating limit.
VariableOutOfLimits	BOOL	Decimal	A device variable that is not mapped to the PV is beyond its operating limits.
CurrentSaturated	BOOL	Decimal	The loop current has reached its upper or lower endpoint limit and cannot increase or decrease any further.
CurrentFixed	BOOL	Decimal	The loop current is being held at a fixed value and is not responding to process variations.
MoreStatus	BOOL	Decimal	More status information is available via command 48, 'Read Additional Status' information.
ColdStart	BOOL	Decimal	A power failure or device reset occurred.
Changed	BOOL	Decimal	An operation was performed that changed the configuration of the device.
Malfunction	BOOL	Decimal	The device detected a serious error or failure that compromises device operation.
ExtDeviceStatus	SINT	Binary	Extended device status (from HART cmd9).
MaintenanceRequired	BOOL	Decimal	Maintenance is needed.
DeviceVariableAlert	BOOL	Decimal	Device reports a problem with some measurement.
PowerLow	BOOL	Decimal	Low power.
ChxPV (Ch 0...Ch7)	REAL	Float	Channel x HART PV value.
ChxSV (Ch 0...Ch7)	REAL	Float	Channel x HART SV value.

Table 25 - 1756-IF8IH Input Tags - Analog and HART PV (AB:1756_IF8IH_HARTPV:I:1)

Member Name	Type	Style	Description
ChxTV (Ch 0...Ch7)	REAL	Float	Channel x HART TV value.
ChxFV (Ch 0...Ch7)	REAL	Float	Channel x HART FV value.
ChxPVStatus (Ch 0...Ch7)	SINT	Hex	Channel x HART PV status. See HART PV, SV, TV, and FV Status on page 236 for more information.
ChxSVStatus (Ch 0...Ch7)	SINT	Hex	Channel x HART SV status. See HART PV, SV, TV, and FV Status on page 236 for more information.
ChxTVStatus (Ch 0...Ch7)	SINT	Hex	Channel x HART TV status. See HART PV, SV, TV, and FV Status on page 236 for more information.
ChxFVStatus (Ch 0...Ch7)	SINT	Hex	Channel x HART FV status. See HART PV, SV, TV, and FV Status on page 236 for more information.

Input - Analog and HART by Channel, Configure HART Device = No

[Table 26](#) describes the input tags available in the Analog with HART Channel Grouped data format for the 1756-IF8IH module when it is used in Legacy 1756-IF8IH mode.

Table 26 - 1756-IF8IH Input Tags - Analog and HART by Channel, Configure HART Device = No (AB:1756_IF8IH_AnalogHARTbyChannel:I:0)

Member Name	Type	Style	Description
ChannelFaults	INT	Binary	Channel fault status bits.
ChxFault (Ch 0...Ch7)	BOOL	Decimal	(ChannelFaults.0...ChannelFaults.7) A fault has occurred on the corresponding channel.
ModuleFaults	SINT	Binary	Module fault status bits.
CalFault	BOOL	Decimal	(ModuleFaults.1) A calibration fault has occurred on one of the channels.
Calibrating	BOOL	Decimal	(ModuleFaults.2) A calibration is in progress.
UpdatedStatusReady	BOOL	Decimal	(ModuleFaults.3) Module has collected updated Additional Device Status from HART command 48. This status can be retrieved by using the Read Additional Status service, 16#4C. For more information about this service, see Read Additional Status (Service Code = 16#4C) on page 181 .
AnalogGroupFault	BOOL	Decimal	(ModuleFaults.7) Indicates that a channel fault has occurred.
Chx (Ch 0...Ch7)	AB:1756_IF8IH_HARTDataAll_Struct:I:0		
Data	REAL	Float	Analog value in engineering units.
DeviceStatus	AB:1756_IF8IH_HARTStatusAll_1_Struct:I:0		
HARTInit	BOOL	Decimal	Searching for or Initializing HART device. If this value is 0 and HARTCommFail is 1, then HART is not enabled on this channel. If both are 1, then 1756-IF8IH is sending out HART messages attempting to establish communication with a HART device.
HARTCommFail	BOOL	Decimal	HART communication failure, device not found, or HART not enabled. If this bit is 1, none of the other data in the HART part of the Input Tag are valid. (HART.PVStatus is also set to 0 to indicate this.)
MsgReady	BOOL	Decimal	Ladder passthrough message reply is ready for query service.
CurrentFault	BOOL	Decimal	Digital and analog values do not match (Analog current measurement does not match the current the Field Device reported over the HART network.
ConfigurationChanged	BOOL	Decimal	The Field Device configuration has changed and new Field Device configuration information can be obtained from the 1756-IF8IH module via CIP MSG GetDeviceInfo, which clears this bit.
BrokenWire	BOOL	Decimal	Indicates that current is not flowing through the module as expected. Broken wiring, RTB removal, or a powered-off field device can cause this.
HARTFault	BOOL	Decimal	Indicates a problem with HART data from the field device on Channel x. Examples are HART not enabled, HART device not connected, HART communication failure due to noise. These field device status conditions also cause this to be set: Device Malfunction, PV Out of Limits, Loop Current Saturated, and Loop Current Fixed.
ResponseCode	SINT	Binary	HART communication status byte or Response code from a recent HART reply. See Response Code and Field Device Status on page 229 for more information.
FieldDeviceStatus	SINT	Binary	HART device status byte from a recent HART reply. Indicates the health of the HART field device. See Field Device Status Bit Mask Definitions on page 230 for more information.

Table 26 - 1756-IF8IH Input Tags - Analog and HART by Channel, Configure HART Device = No (AB:1756_IF8IH_AnalogHARTbyChannel:I:0)

Member Name	Type	Style	Description
PVOutOfLimits	BOOL	Decimal	(FieldDeviceStatus.0) The primary variable is beyond its operating limit.
VariableOutOfLimits	BOOL	Decimal	(FieldDeviceStatus.1) A device variable that is not mapped to the PV is beyond its operating limits.
CurrentSaturated	BOOL	Decimal	(FieldDeviceStatus.2) The loop current has reached its upper or lower endpoint limit and cannot increase or decrease any further.
CurrentFixed	BOOL	Decimal	(FieldDeviceStatus.3) The loop current is being held at a fixed value and is not responding to process variations.
MoreStatus	BOOL	Decimal	(FieldDeviceStatus.4) More status information is available via command 48, 'Read Additional Status' information.
ColdStart	BOOL	Decimal	(FieldDeviceStatus.5) A power failure or device reset occurred.
Changed	BOOL	Decimal	(FieldDeviceStatus.6) An operation was performed that changed the configuration of the device.
Malfunction	BOOL	Decimal	(FieldDeviceStatus.7) The device detected a serious error or failure that compromises device operation.
AlarmStatus	SINT	Binary	Channel x alarm status bits.
HHAlarm	BOOL	Decimal	ChxData > ChxHHAlarmLimit. If Process Alarms are configured to Latch by setting ChxConfig.ProcessAlarmLatch this bit remains set even after the condition returns to normal, until reset via explicit CIP message. This message can be sent from the Studio 5000 Module Properties Alarm dialog box or from the Logix controller via MSG instruction.
LLAlarm	BOOL	Decimal	ChxData < ChxLLAlarmLimit. If ChxConfig.ProcessAlarmLatch is set, this alarm remains set until it is unlatched.
HAlarm	BOOL	Decimal	ChxData > ChxHAlarmLimit. If ChxConfig.ProcessAlarmLatch is set, this alarm remains set until it is unlatched.
LAlarm	BOOL	Decimal	ChxData < ChxLAlarmLimit. If ChxConfig.ProcessAlarmLatch is set, this alarm remains set until it is unlatched.
RateAlarm	BOOL	Decimal	ChxData changing faster than ChxRateAlarmLimit. Both Positive and Negative changes can cause this alarm. If ChxConfig.RateAlarmLatch is set, this alarm remains set until it is unlatched.
Overrange	BOOL	Decimal	Analog signal is greater than or equal to the maximum detectable signal. Because the signal cannot be measured, it can be significantly above the maximum value.
Underrange	BOOL	Decimal	Analog signal is less than or equal to the minimum detectable signal. Because the signal cannot be measured, it can be significantly below the minimum value.
CalFault	BOOL	Decimal	Set if an error occurs during calibration for Channel x, which causes a bad calibration. Also sets CalFault.
ExtDeviceStatus	INT	Binary	Extended device status (from HART cmd9).
MaintenanceRequired	BOOL	Decimal	Maintenance is needed.
DeviceVariableAlert	BOOL	Decimal	Device reports a problem with some measurement.
PowerLow	BOOL	Decimal	Low power.
PV	REAL	Float	Channel x HART PV value.
SV	REAL	Float	Channel x HART SV value.
TV	REAL	Float	Channel x HART TV value.
FV	REAL	Float	Channel x HART FV value.
PVStatus	HEX	SINT	Channel x HART PV status. See HART PV, SV, TV, and FV Status on page 236 for more information.
SVStatus	HEX	SINT	Channel x HART SV status. See HART PV, SV, TV, and FV Status on page 236 for more information.
TVStatus	HEX	SINT	Channel x HART TV status. See HART PV, SV, TV, and FV Status on page 236 for more information.
FVStatus	HEX	SINT	Channel x HART FV status. See HART PV, SV, TV, and FV Status on page 236 for more information.
CSTTimeStamp	HEX	DINT (2)	
RollingTimeStamp	HEX	INT	

Input - Analog and HART by Channel, Configure HART Device = Yes

Table 27 describes the input tags available in the Analog and HART by Channel data format for the 1756-IF8IH module when Configure HART Device = Yes.

Table 27 - 1756-IF8IH Input Tags - Analog and HART by Channel, Configure HART Device = Yes (AB:1756_IF8IH_AnalogHARTbyChannel_1:l:0)

Member Name	Type	Style	Description
ChannelFaults	INT	Binary	(ChannelFaults.0...ChannelFaults.15) Channel Fault Bits.
ChxFault (Ch0...Ch7)	BOOL	Decimal	(ChannelFaults.0...ChannelFaults.7) Indicates that a fault has occurred on the corresponding channel.
ModuleFaults	SINT	Binary	ModuleFaults.0...ModuleFaults.7
CalFault	BOOL	Decimal	(ModuleFaults.1) A calibration fault has occurred.
Calibrating	BOOL	Decimal	(ModuleFaults.2) Calibration is in progress.
UpdatedStatusReady	BOOL	Decimal	(ModuleFaults.3) Updated status from HART Cmd48 is available.
AnalogGroupFault	BOOL	Decimal	(ModuleFaults.7) A channel fault has occurred.
Chx (Ch0...Ch7)	AB:1756_IF8IH_HARTDataAll_1_Struct:l:0		
Data	REAL	Float	Analog value in engineering units.
DeviceStatus	AB:1756_IF8IH_HARTStatusAll_1_Struct:l:0		
HARTInit	BOOL	Decimal	Searching for or Initializing HART device. If this value is 0 and HARTCommFail is 1, then HART is not enabled on this channel. If both are 1, then 1756-IF8IH is sending out HART messages to attempt to establish communication with a HART device.
HARTCommFail	BOOL	Decimal	HART communication failure, device not found, or HART not enabled. If this bit is 1, none of the other data in the HART part of the Input Tag are valid. (HART.PVStatus is also set to 0 to indicate this.)
MsgReady	BOOL	Decimal	Ladder passthrough message reply is ready for query service.
CurrentFault	BOOL	Decimal	Digital and analog values do not match. (Analog current measurement does not match the current the Field Device reported over the HART network.)
ConfigurationChanged	BOOL	Decimal	The Field Device configuration has changed and new Field Device configuration information can be obtained from the 1756-IF8IH module via CIP MSG GetDeviceInfo, which clears this bit.
BrokenWire	BOOL	Decimal	Indicates that current is not flowing through the module as expected. Broken wiring, RTB removal, or a powered-off field device can cause this.
HARTFault	BOOL	Decimal	Indicates a problem with HART data from the field device on Channel x. Examples are HART not enabled, HART device not connected, HART communication failure due to noise. These field device status conditions also cause this to be set: Device Malfunction, PV Out of Limits, Loop Current Saturated, and Loop Current Fixed.
ResponseCode	SINT	Binary	Communication error / command response.
FieldDeviceStatus	SINT	Binary	Field device status (bits 0...7).
PVOutOfLimits	BOOL	Decimal	(FieldDeviceStatus.0) The primary variable is beyond its operating limit.
VariableOutOfLimits	BOOL	Decimal	(FieldDeviceStatus.1) A device variable that is not mapped to the PV is beyond its operating limits.
CurrentSaturated	BOOL	Decimal	(FieldDeviceStatus.2) The loop current has reached its upper or lower endpoint limit and cannot increase or decrease any further.
CurrentFixed	BOOL	Decimal	(FieldDeviceStatus.3) The loop current is being held at a fixed value and is not responding to process variations.
MoreStatus	BOOL	Decimal	(FieldDeviceStatus.4) More status information is available via command 48, 'Read Additional Status' information.
ColdStart	BOOL	Decimal	(FieldDeviceStatus.5) A power failure or device reset occurred.
Changed	BOOL	Decimal	(FieldDeviceStatus.6) An operation was performed that changed the configuration of the device.
Malfunction	BOOL	Decimal	(FieldDeviceStatus.7) The device detected a serious error or failure that compromises device operation.
AlarmStatus	SINT	Binary	Alarm status (bits 0...7)
PVConfigFailed	BOOL	Decimal	(AlarmStatus.0) PV auto-config failed (See HART Command Tab - 1756-IF8IH, 1756-OF8IH on page 169).

Table 27 - 1756-IF8IH Input Tags - Analog and HART by Channel, Configure HART Device = Yes (AB:1756_IF8IH_AnalogHARTbyChannel_1:I:0)

Member Name	Type	Style	Description
Overrange	BOOL	Decimal	(AlarmStatus.5) Signal value is over the specified input range.
Underrange	BOOL	Decimal	(AlarmStatus.6) Signal value is under the specified input range.
CalFault	BOOL	Decimal	(AlarmStatus.7) Bad calibration.
ExtDeviceStatus	SINT	Binary	Extended device status (bits 0...7) (from HART cmd9)
MaintenanceRequired	BOOL	Decimal	(ExtDeviceStatus.0)
DeviceVariableAlert	BOOL	Decimal	(ExtDeviceStatus.1) Device reports a problem with some measurement.
PowerLow	BOOL	Decimal	(ExtDeviceStatus.2)
CalibrationFault	BOOL	Decimal	Last attempted calibration for this channel failed.
Calibrating	BOOL	Decimal	Calibration for the channel is in progress.
CalGoodLowRef	BOOL	Decimal	A valid Low Reference signal has been sampled on this channel.
CalBadLowRef	BOOL	Decimal	The Low Reference signal is grossly out of the expected range.
CalGoodHighRef	BOOL	Decimal	A valid high reference signal has been sampled on the channel.
CalBadHighRef	BOOL	Decimal	The high reference signal is grossly out of the expected range.
CalSuccessful	BOOL	Decimal	This bit is set after valid High and Low points are captured and the Calibrate bit in the output word has been cleared.
PV	REAL	Float	Channel x HART PV value.
SV	REAL	Float	Channel x HART SV value.
TV	REAL	Float	Channel x HART TV value.
FV	REAL	Float	Channel x HART FV value.
PVStatus	HEX	SINT	Channel x HART PV status. See HART PV, SV, TV, and FV Status on page 236 for more information.
SVStatus	HEX	SINT	Channel x HART SV status. See HART PV, SV, TV, and FV Status on page 236 for more information.
TVStatus	HEX	SINT	Channel x HART TV status. See HART PV, SV, TV, and FV Status on page 236 for more information.
FVStatus	HEX	SINT	Channel x HART FV status. See HART PV, SV, TV, and FV Status on page 236 for more information.
CSTimeStamp	HEX	DINT (2)	Timestamp that is taken at the time the input data was sampled in terms of coordinated system time, which is a 64-bit value in microseconds coordinated across the modules in the 1756 backplane.
RollingTimeStamp	HEX	INT	Timestamp that is taken at the time the input data was sampled in millisecond resolution.

Output - Analog and HART by Channel, Configure HART Device = Yes

[Table 28](#) describes the output tags available in the Analog and HART by Channel data format for the 1756-IF8IH module when Configure HART Device = Yes. Output tags are not available in other 1756-IF8IH data formats.

Table 28 - 1756-IF8IH Output Tags - Analog and HART by Channel, Configure HART Device = Yes (AB:1756_IF8IH:0:0)

Member Name	Type	Style	Description
ChxCalibrate (Ch 0...Ch7)	BOOL	Decimal	Initiates the Calibration Process. Must stay set through a valid LowReference and HighReference. Clearing prior Aborts Calibration.
ChxCaLowRef (Ch 0...Ch7)	BOOL	Decimal	Rising edge triggers a Low Calibration at the Low Reference Point (0.5 mA). Valid Low Reference signal must be connected before setting bit.
ChxCaHighRef (Ch 0...Ch7)	BOOL	Decimal	Rising edge triggers a High Calibration at the High Reference Point (20 mA). Valid High Reference signal must be connected before setting bit.
CalibrationDate	INT	Decimal	Date of most recent successful calibration.

1756-IF16H HART Analog Input Module

This chapter discusses these topics.

Topic	Page
Module Features	75
Wire the Module	80
Circuit Diagram	82
1756-IF16H Module Fault and Status Reporting	83
Module-defined Data Types, 1756-IF16H Module	86

Module Features

The 1756-IF16H module has the following features:

- Choice of three data formats
 - Analog only
 - Analog and HART PV
 - Analog and HART by channel
- 0...20 mA or 4...20 mA input ranges
- Module filter
- Real-time sampling
- Underrange and overrange detection
- Wire-off detection
- Highway addressable remote transducer (HART) communication

Data Formats

Data format determines which values are included in the Input tag of the module and the features that are available to your application. Select the data format on the General tab in the Studio 5000 Logix Designer® application. [Table 29](#) shows the available data formats for the 1756-IF16H module.

Table 29 - Data Formats for the 1756-IF16H Module

Format	Description			
	Analog signal values	Analog status	HART secondary process variables and device health	HART and Analog data for each channel grouped in tag
Analog Only	X	X		
Analog and HART PV	X	X	X	
Analog and HART by Channel	X	X	X	X

- Choose Analog and HART PV if you prefer the members of your tag to be arranged similar to non-HART analog input modules. With this selection, the analog values for all channels grouped near the end of the tag. This arrangement makes it easy to view all 16 analog values at once.
- Choose Analog and HART by Channel if you prefer Status, Analog Value, and Device Status for each channel to be together in the tag. This arrangement makes it easier to view all data that is related to one field device.

Input Ranges

You can select one of two input ranges for each channel on the module. The range designates the minimum and maximum signals that are detectable by the module. The two ranges are:

- 0...20 mA
- 4...20 mA (HART instruments use this range)

Module Filter

The module filter attenuates the input signal beginning at the specified frequency. This feature is applied on a module-wide basis, which affects all channels.

The module attenuates the selected frequency by approximately -3 dB or 0.707 of the applied amplitude.

An input signal with frequencies above the selected frequency is attenuated more while frequencies below the selection receive no attenuation.

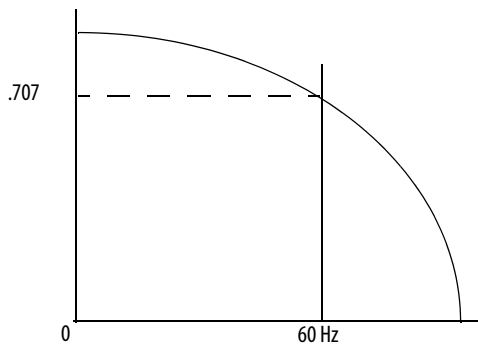

A by-product of the filter selection is the minimum sample rate (RTS) that is available. For example, the 1000 Hz selection does not attenuate any frequencies less than 1000 Hz, and provides for sampling of all 16 channels within 18 ms. The 15 Hz selection attenuates all frequencies above 15 Hz and provides only for sampling all 16 channels within 328 ms.

IMPORTANT Do not use the 1000 Hz module filter with HART instruments.

IMPORTANT 60 Hz is the default setting for the module filter. This setting provides approximately 3 dB of attenuation of a 60 Hz input.

Use [Table 30](#) to choose a module filter setting.

Table 30 - Module Filter Selections with Associated Performance Data

Module Filter Selection (-3 dB) ⁽¹⁾	15 Hz	20 Hz	50 Hz	60 Hz	100 Hz	250 Hz	1000 Hz
Minimum Sample Time (RTS)	328 ms	275 ms	115 ms	115 ms	61 ms	25 ms	11 ms
Effective Resolution	18 bits	18 bits	17 bits	17 bits	16 bits	16 bits	15 bits
	0.08 μ A	0.08 μ A	0.16 μ A	0.16 μ A	0.32 μ A	0.32 μ A	0.64 μ A
50 Hz Rejection	74 dB	48 dB	6 dB	6 dB	1 dB	0.1 dB	–
60 Hz Rejection	74 dB	97 dB	9 dB	9 dB	2 dB	0.2 dB	–

(1) Worst case settling time to 100% of a step change is double the real-time sample time.

Real-time Sampling (RTS)

This parameter instructs the module how often to scan its input channels and obtain all available data. After the channels are scanned, the module multicasts that data. This feature is applied on a module-wide basis.

During module configuration, you specify a real-time sampling (RTS) period and a requested packet interval (RPI) period. Both of these features instruct the module to multicast data, but only the RTS feature instructs the module to scan its channels before multicasting.

Underrange and Overrange Detection

The module detects when it is operating beyond limits of the input range. This status indication tells you that the input signal is not being measured accurately because the signal is beyond the measuring capability of the module. For example, the module cannot distinguish between 20.5 mA and 22 mA

[Table 31](#) shows the input ranges of the 1756-IF16H module and the lowest and highest signal available in each range before the module detects an underrange and overrange condition.

Table 31 - Low and High Signal Limits on the 1756-IF16H Module

Module	Available Range	Lowest Signal in Range	Highest Signal in Range
1756-IF16H	0...20 mA	0 mA	20.58 mA
	4...20 mA	3.42 mA	20.58 mA

Digital Filter

The digital filter smooths input data noise transients. This feature is applied on a **per channel** basis.

The digital filter value specifies the time constant for a digital first order lag filter on the input. It is specified in units of milliseconds. A value of 0 disables the filter.

The digital filter equation is a classic first order lag equation.

$$Y_n = Y_{n-1} + \frac{[\Delta t]}{\Delta t + T_A} (X_n - Y_{n-1})$$

Y_n = present output, filtered peak voltage (PV)

Y_{n-1} = previous output, filtered PV

Δt = module channel update time (seconds)

T_A = digital filter time constant (seconds)

X_n = present input, unfiltered PV

[Figure 15](#) uses a step input change to illustrate the filter response. When the digital filter time constant elapses, 63.2% of the total response is reached. Each additional time constant achieves 63.2% of the remaining response.

Figure 15 - Filter Response

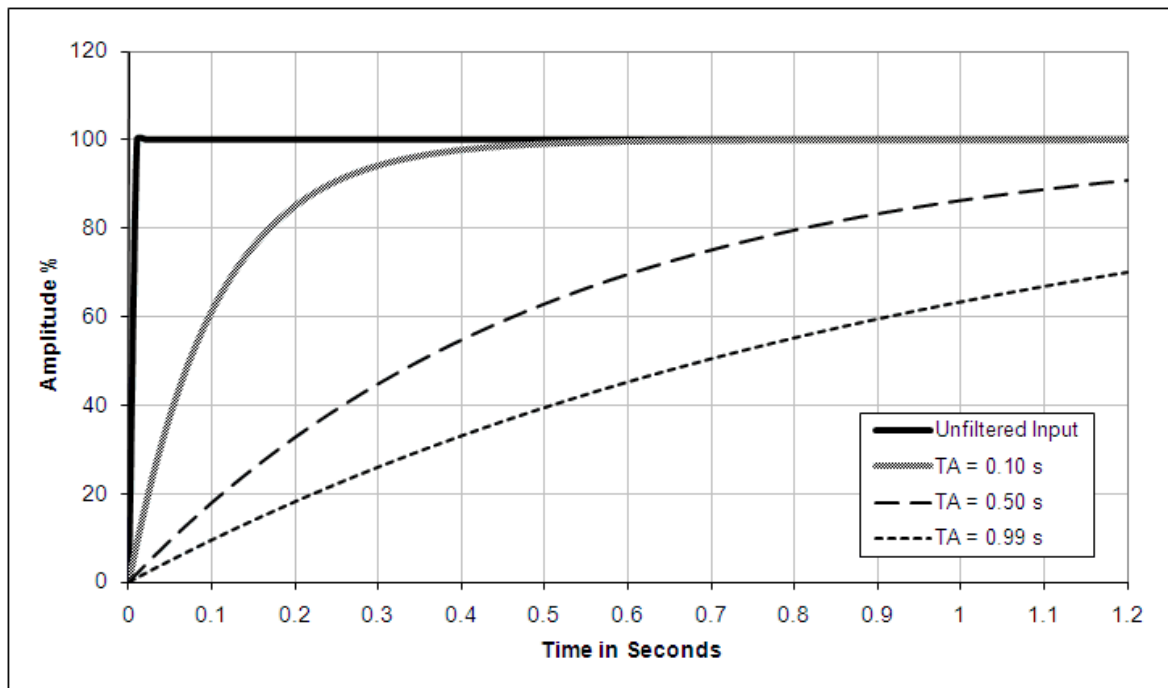

Wire-off Detection

The 1756-IF16H module alerts you when a signal wire is disconnected from one of its channels or the RTB is removed from the module if the channel is configured for 4...20 mA range. When a wire-off condition occurs for this module, two events occur:

- Input data for that channel changes to the scaled value that corresponds to the Underrange condition.
- A fault bit is set in the input tag (ChxxUnderrange and ChxxBrokenWire tags are set to 1), which can indicate the presence of a wire-off condition.

Wire the Module

Use this information to wire the current inputs.

Figure 16 - Current Inputs

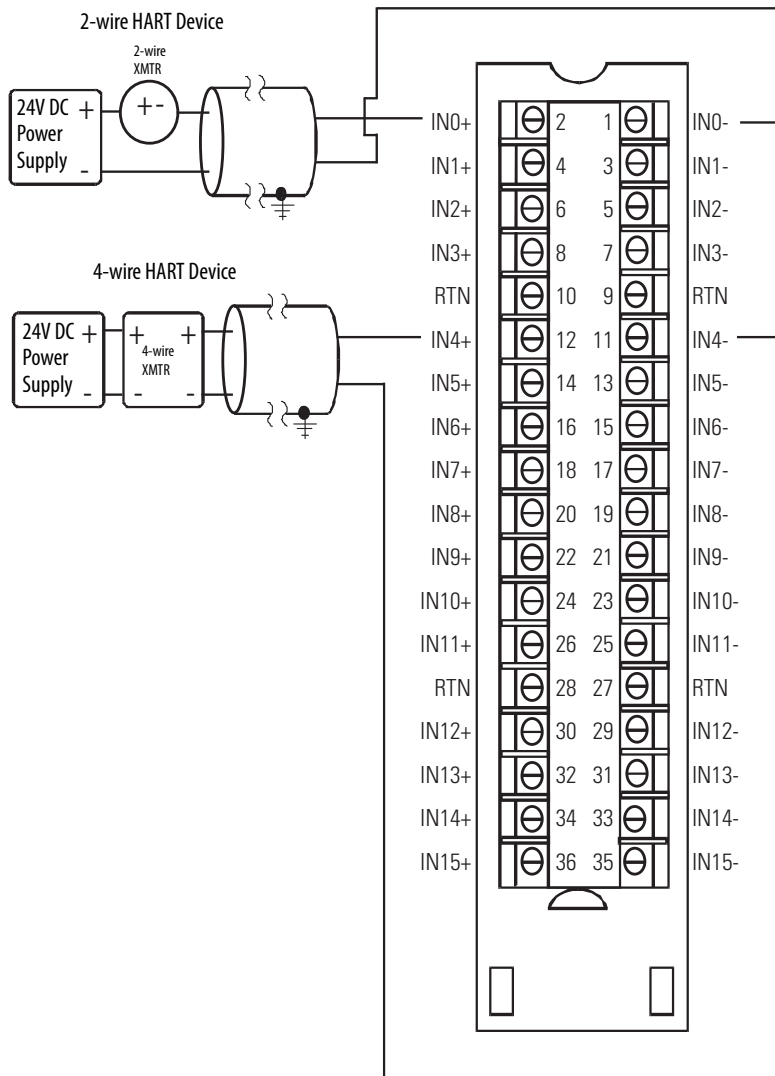

Channel	Pin #	Usage	Usage	Pin #
00	2	IN00+	IN00-	1
01	4	IN01+	IN01-	3
02	6	IN02+	IN02-	5
03	8	IN03+	IN03-	7
	10	RTN	RTN	9
04	12	IN04+	IN04-	11
05	14	IN05+	IN05-	13
06	16	IN06+	IN06-	15
07	18	IN07+	IN07-	17
08	20	IN08+	IN08-	19
09	22	IN09+	IN09-	21
10	24	IN10+	IN10-	23
11	26	IN11+	IN11-	25
	28	RTN	RTN	27
12	30	IN12+	IN12+	29
13	32	IN13+	IN13+	31
14	34	IN14+	IN14+	33
15	36	IN15+	IN15+	35

45124

The 1756-IF16H is a differential input module. However there are limitations on its use in differential mode. Any time the low ends of the terminal block pins are connected together they must also be jumpered to the RTN pin on the terminal block. There are two scenarios in which this shared connection is needed.

First, if one power supply is used for multiple devices then the low ends from the channels are connected together and connected to the ground return of the power supply. See [Figure 17](#).

Figure 17 - Single Power Supply with Multiple HART Devices

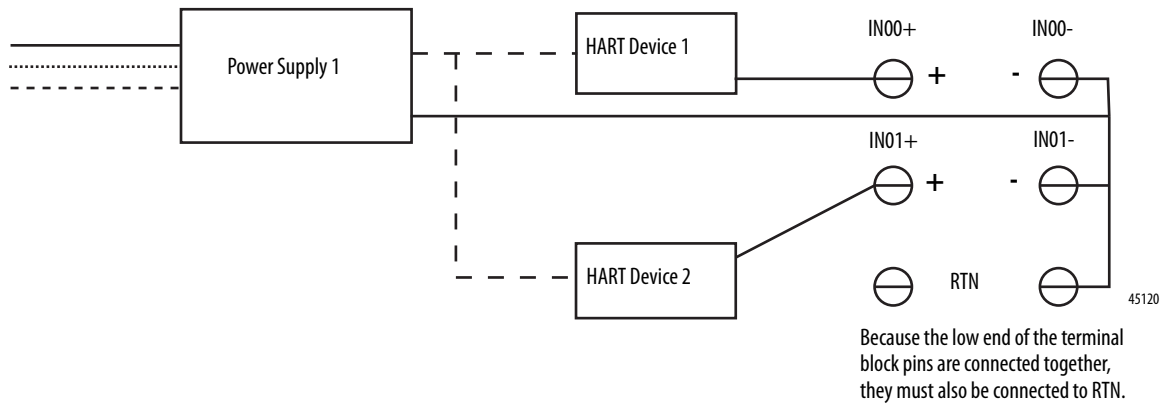

Second, if multiple power supplies are used, they can be connected to the same ground. In this case, the low ends of the channels are effectively connected together by the common grounds of the power supplies.

Figure 18 - Multiple Power Supplies with a Common Ground

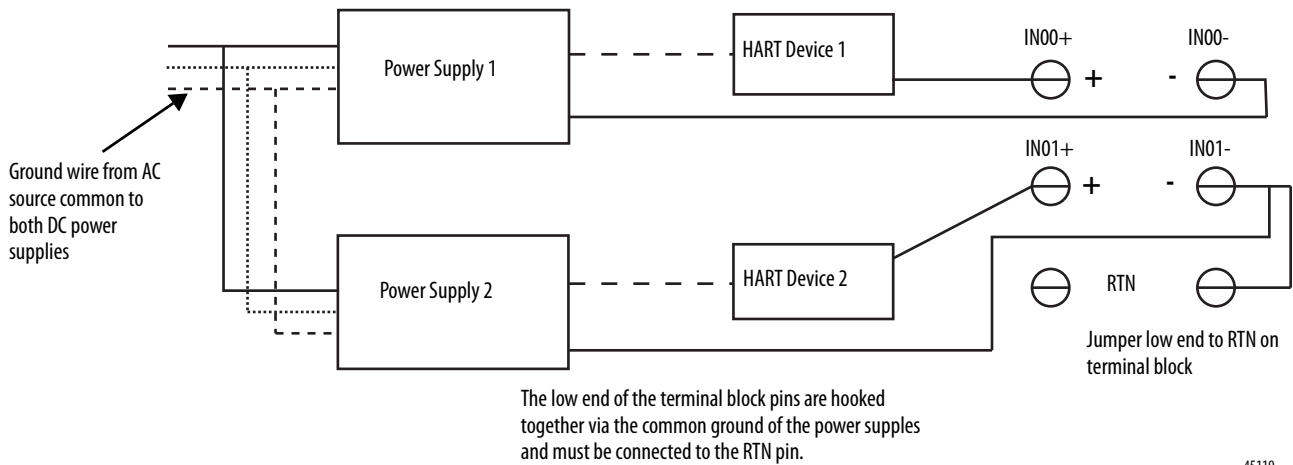

For devices powered by separate supplies, when the ground potential of the supplies is expected to differ, differential mode is recommended. Using differential mode prevents ground loop currents from flowing between the supplies. However, the potential difference allowable between the supplies must remain within specified limits.

Figure 19 - Power Supplies with Isolated Grounds

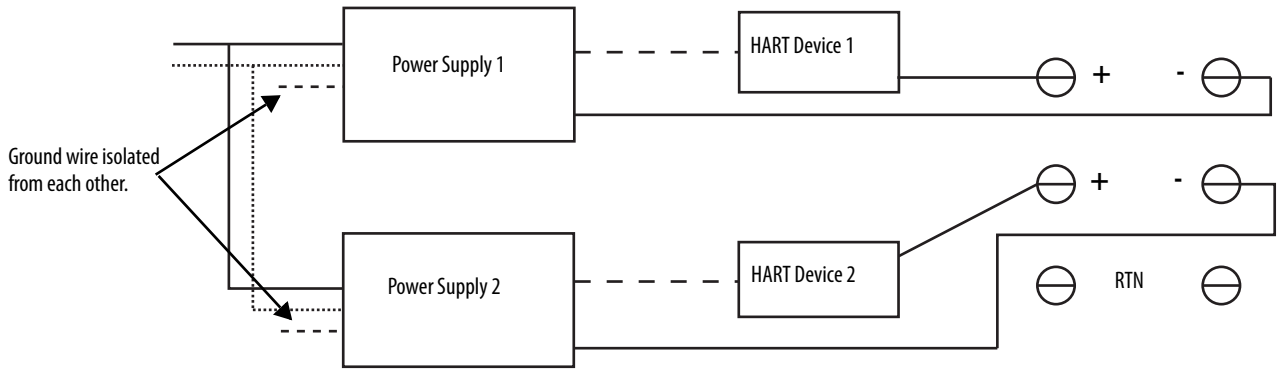

The low end of the terminal block pins are now isolated from each other and the inputs can be configured as true differential inputs as long as the voltage difference between them does not exceed 7V.

45121

Some devices, such as AC powered four wire devices, are recommended to be used in differential mode only. Combinations of differential and single-ended configurations are allowed but care must be taken to make sure that the differential input grounds really are isolated from the single-ended inputs.

Circuit Diagram

This figure is a simplified input circuit diagram for the 1756-IF16H module.

Figure 20 - 1756-IF16H Simplified Current Input Circuit

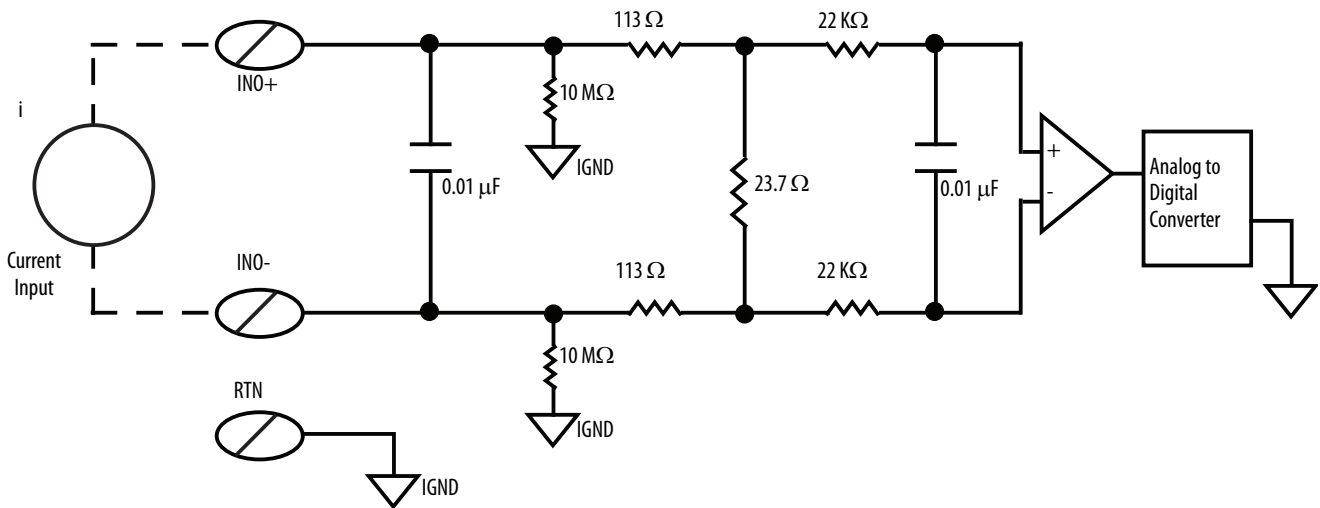

1756-IF16H Module Fault and Status Reporting

The 1756-IF16H module sends status/fault data to the controller with its channel data. The fault data is arranged to let you choose the level of granularity you desire for examining fault conditions. Three levels of tags work together to provide an increasing degree of detail as to the specific cause of faults on the module.

[Table 32](#) shows the tags that can be examined in ladder logic to indicate when a fault has occurred.

Table 32 - 1756-IF16H Tags That Can Be Examined in Ladder Logic

Tag	Description	Tag Name Analog and HART PV	Tag Name Analog and HART by Channel
Module Fault Word	This word provides fault summary reporting.	ModuleFaults	ModuleFaults
Channel Fault Word	This word provides clamp and communication fault reporting.	ChannelFaults ChxxFault	ChannelFaults ChxxFault
Channel Status Tags	These words provide individual channel limit, hold, open wire, ramp status, and calibration faults.	ChxxStatus	Chxx.Device Status Chxx.DeviceStatus.AlarmStatus
HART Faults	This provides HART communication status.	HARTFaults, ChxxHARTFault	Chxx.DeviceStatus.HARTFault
HART Device Status	This provides HART field device health.	HART.ChxxDevice Status	Chxx.DeviceStatus.FieldDeviceStatus

1756-IF16H Module Fault Reporting

Figure 21 offers an overview of the fault reporting process for the 1756-IF16H module.

Figure 21 - 1756-IF16H Module Fault Reporting

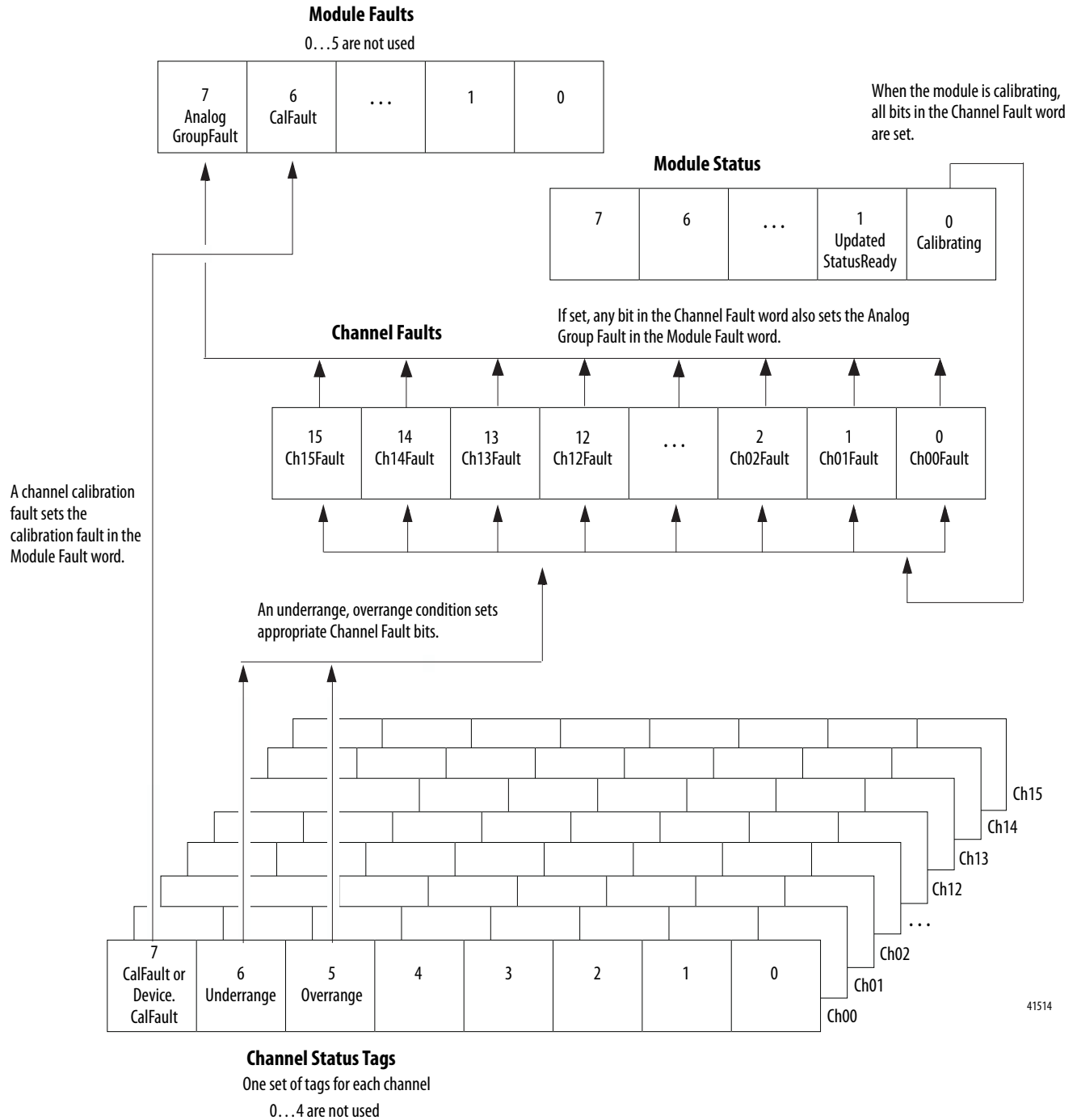

1756-IF16H Module Fault Word Bits

Bits in this word provide the highest level of fault detection. A nonzero condition in this word reveals that a fault exists on the module. You can examine further to isolate the fault. [Table 33](#) lists tags that can be examined in ladder logic to indicate when a fault has occurred.

Table 33 - 1756-IF16H Tags That Can Be Examined in Ladder Logic

Tag	Description
Analog Group Fault	This bit is set when any bits in the Channel Fault word are set. Its tag name is AnalogGroupFault.
Calibration Fault	This bit is set when any of the individual Channel Calibration Fault bits are set. Its tag name is CalFault.

1756-IF16H Channel Fault Tags

During normal module operation, bits in the Channel Fault word are set if any of the respective channels has an Under or Overrange condition. Checking this word for a nonzero value is a quick way to check for Under or Overrange conditions on the module.

Channel Fault bits for all channels are also set (16#FFFF) if calibration is being performed or a communication fault has occurred between the module and its owner controller.

1756-IF16H Channel Status Tags

[Table 34](#) describes the channel status tags.

Table 34 - 1756-IF16H Tags That Show Channel Status⁽¹⁾

Tag	Bit	Description
ChxCalFault	7	This bit is set if an error occurs during calibration for Channel <i>x</i> , which causes a bad calibration. Also sets CalFault in the Module Faults.
ChxUnderrange	6	This bit is set when the analog signal is less than or equal to the minimum detectable signal. Because the signal cannot be measured, it can be significantly below the minimum value. Also sets ChxxFault in the Channel Faults.
ChxOverrange	5	This bit is set when the analog signal is greater than or equal to the maximum detectable signal. Because the signal cannot be measured, it can be significantly above the maximum value. Also sets ChxxFault in the Channel Faults.

(1) Bits 0...4 are not used.

Module-defined Data Types, 1756-IF16H Module

[Table 35...Table 39](#) describe module-defined data types for the 1756-IF16H module and include information for configuration and input tags.

Available tags depend on the selected input data format, as shown in the table.

Table 35 - 1756-IF16H Input Data Choice and Tags

Input Data Choice	Tag	Main Module Defined Type	Subtype Used by Main Type
Analog Only	Configuration	AB:1756_IF16H:C:0	AB:1756_IF16H_ChConfig_Struct:C:0
	Input	AB:1756_IF16H_Analog:I:0	None
Analog and HART PV	Configuration	AB:1756_IF16H:C:0	AB:1756_IF16H_ChConfig_Struct:C:0
	Input	AB:1756_IF16H_HARTPV:I:0	AB:1756_IF16H_HARTData:I:0 AB:1756_IF16H_HARTStatus_Struct:I:0
Analog and HART by Channel	Configuration	AB:1756_IF16H:C:0	AB:1756_IF16H_ChConfig_Struct:C:0
	Input	AB:1756_IF16H_AnalogHARTbyChannel:I:0	AB:1756_IF16H_HARTDataAll_Struct:I:0 AB:1756_IF16H_HARTStatusAll_Struct:I:0

Configuration

[Table 36](#) describes the configuration tags available for the 1756-IF16H module.

Table 36 - 1756-IF16H Configuration Tags (AB:1756_IF16H:C:0)

Member Name	Type	Style	Description
ModuleFilter (bits 0...7)	SINT	Decimal	See the Module Filter Selections with Associated Performance Data table on page 77 .
RealTimeSample (bits 0...15)	INT	Decimal	Milliseconds between reading signal values. See Real-time Sampling (RTS) on page 78 for more information.
ChxxConfig (xx = 00...15)	AB:1756_IF16H_ChConfig_Struct:C:0		
Config	SINT	Binary	
HARTEn	BOOL	Decimal	ChxxConfig.Config.7, Enable HART communication. Must be 1 for valid HART data in input tag and asset management access to HART field device.
RangeType	SINT	Decimal	0 = 0...20 mA 1 = 4...20 mA
DigitalFilter	INT	Decimal	Time constant of low pass filter in ms. See Digital Filter on page 79 for more information.
LowSignal	REAL	Float	Lower current value for scaling to engineering units. Default is 4 mA. Must be less than HighSignal and more than or equal to the minimum input range. See Scaling to Engineering Units on page 153 for more information.
HighSignal	REAL	Float	Upper current value for scaling to engineering units. Default is 20 mA. Must be more than LowSignal and less than or equal to the maximum input Range. See Scaling to Engineering Units on page 153 for more information.
LowEngineering	REAL	Float	Measured quantity in engineering units that results in a signal level equal to LowSignal. See Scaling to Engineering Units on page 153 for more information.
HighEngineering	REAL	Float	Measured quantity in engineering units that results in a signal level equal to HighSignal. See Scaling to Engineering Units on page 153 for more information.
CalBias	REAL	Float	Sensor Offset in engineering units added to the measured signal before reporting Chxx.Data.
PassthroughHandle Timeout	INT	Decimal	Seconds to keep a reply to a HART pass-through service request before discarding; 15 seconds is recommended.

Analog Only

[Table 37](#) describes the input tags available in the Analog Only data format for the 1756-IF16H module.

Table 37 - 1756-IF16H Input Tags - Analog Only (AB:1756_IF16H_Analog:I:0)

Member Name	Type	Style	Description
ChannelFaults (bits 0...15)	INT	Binary	Indicates a problem with analog data on Channel x or broken communication between the Logix controller and the 1756-IF16H module. Example: Set if analog signal is larger than 20 mA.
ChxxFault (xx = 00...15)	BOOL	Decimal	ChannelFaults.0...ChannelFaults.15
Module Status	SINT	Binary	
Calibrating	BOOL		ModuleStatus.0, Calibration in progress
UpdatedStatusReady	BOOL		ModuleStatus.1, Module has collected updated Additional Device Status from HART command 48. This status can be retrieved by using the Read Additional Status service, 16#4C. For more information about this service, see Read Additional Status (Service Code = 16#4C) on page 181 .
ModuleFaults	SINT	Binary	Module level fault status bits (bits 0...5 not used)
CalFault	BOOL	Decimal	(ModuleFaults.6) 1756-IF16H Module Calibration Failed.
AnalogGroupFault	BOOL	Decimal	(ModuleFaults.7) Indicates that a fault has occurred on any channel (any of ChannelFaults).
BrokenWireFaults (bit 0...15)	INT	Binary	Indicates that current is not flowing through the module as expected. Broken wiring, RTB removal, or a powered-off field device can cause this. If configured for 4...20 mA, a broken wire fault sets this bit.
ChxxBroken Wire	BOOL	Decimal	BrokenWireFaults.0...BrokenWireFaults.15
HARTFaults (Ch00...Ch15)	INT	Binary	Indicates a problem with HART data from the Field Device on Channel x. Examples are HART not enabled, HART device not connected, HART communication failure due to noise. These Field Device Status conditions also cause this to be set: Device Malfunction, PV Out of Limits, Loop Current Saturated, and Loop Current Fixed.
ChxxHARTFault	BOOL	Decimal	HARTFaults.0...HARTFaults.15
ChxxStatus (xx = 00...15)	SINT	Binary	Indicates various alarms on the analog signal. Also sets ChxxFault.
ChxxOverrange	BOOL		ChxxStatus.5 Analog signal is greater than or equal to the maximum detectable signal. Because the signal cannot be measured, it can be significantly above the maximum value.
ChxxUnderrange	BOOL		ChxxStatus.6 Analog signal is less than or equal to the minimum detectable signal. Because the signal cannot be measured, it can be significantly below the minimum value.
ChxxCalFault	BOOL		ChxxStatus.7 Set if an error occurs during calibration for Chxx, which causes a bad calibration. Also sets CalFault.
ChxxData (xx = 00...15)	REAL	Float	Value of analog signal on Channel xx after conversion to engineering units.
CSTimestamp	DINT[2]	Hex	Timestamp that is taken at the time the input data was sampled in terms of Coordinated System Time, which is a 64-bit value in microseconds coordinated across the modules in the 1756 backplane.
RollingTimestamp	INT	Decimal	Timestamp that is taken at the time the input data was sampled in millisecond resolution.

Analog and HART PV

Table 38 describes the input tags available in the Analog and HART PV data format for the 1756-IF16H module.

Table 38 - 1756-IF16H Input Tags - Analog and HART PV (AB:1756_IF16H_HARTPV:I:0)

Member Name	Type	Style	Description
ChannelFaults (bit0...15)	INT	Binary	Indicates a problem with analog data on Channel x or broken communication between the Logix controller and the 1756-IF16H module. Example: Set if analog signal is larger than 20 mA.
ChxxFault (xx = 00...15)	BOOL	Decimal	ChannelFaults.0...ChannelFaults.15
ModuleStatus	SINT	Binary	
Calibrating	BOOL		(ModuleStatus.0) Calibration in progress.
UpdatedStatusReady	BOOL		(ModuleStatus.1) Module has collected updated Additional Device Status from HART command 48. This status can be retrieved by using the Read Additional Status service, 16#4C. For more information about this service, see Read Additional Status (Service Code = 16#4C) on page 181 .
ModuleFaults	SINT	Binary	(bits0...5 not used)
CalFault	BOOL	Decimal	(ModuleFaults.6) 1756-IF16H Module Calibration Failed.
AnalogGroupFault	BOOL	Decimal	(ModuleFaults.7) Indicates that a fault has occurred on any channel (any of ChannelFaults).
BrokenWireFaults (bit 0...15)	INT	Binary	Indicates that current is not flowing through the module as expected. Broken wiring, RTB removal, or a powered-off field device can cause this.
ChxxBroken Wire	BOOL	Decimal	BrokenWireFaults.0...BrokenWireFaults.15
HARTFaults	INT	Binary	Indicates a problem with HART data from the Field Device on Channel x. Examples are HART not enabled, HART device not connected, HART communication failure due to noise. These Field Device Status conditions also cause this to be set: Device Malfunction, PV Out of Limits, Loop Current Saturated, and Loop Current Fixed.
ChxxHARTFault	BOOL	Decimal	HARTFaults.0...HARTFaults.15
ChxxStatus (xx = 00...15)	SINT	Binary	Indicates various alarms on the analog signal. Also sets ChxxFault for Overrange, Underrange, and/or CalFault.
ChxxOverrange	BOOL		(ChxxStatus.05) Analog signal is greater than or equal to the maximum detectable signal. Because the signal cannot be measured, it can be significantly above the maximum value.
ChxxUnderrange	BOOL		(ChxxStatus.06) Analog signal is less than or equal to the minimum detectable signal. Because the signal cannot be measured, it can be significantly below the minimum value.
ChxxCalFault	BOOL		(ChxxStatus.07) Set if an error occurs during calibration for Channel x, which causes a bad calibration. Also sets CalFault.
ChxxData (xx = 00...15)	REAL	Float	Value of analog signal on Channel xx after conversion to engineering units.
CSTimestamp	DINT[2]	Hex	Timestamp that is taken at the time the input data was sampled in terms of Coordinated System Time, which is a 64-bit value in microseconds coordinated across the modules in the 1756 backplane.
RollingTimestamp	INT	Decimal	Timestamp that is taken at the time the input data was sampled in millisecond resolution.
HART	AB:1756_IF16H_HARTData:I:0, Contains HART field device health and dynamic process variables.		
ChxxDeviceStatus (xx = 00...15)	AB:1756_IF16H_HARTStatus_Struct:I:0, Channel 0 HART Device status info.		
Init	BOOL		Searching for or Initializing HART device. If this value is 0 and Fail is 1, then HART is not Enabled on this channel. If both are 1, then 1756-IF16H is sending out HART messages to attempt to establish communication with a HART device.
Fail	BOOL		HART communication failure or device not found or HART not enabled. If this bit is 1, none of the other data in the HART part of the Input Tag are valid. (HART.PVStatus is also set to 0 to indicate this.)
MsgReady	BOOL		Pass-through message reply is ready for Query service.

Table 38 - 1756-IF16H Input Tags - Analog and HART PV (AB:1756_IF16H_HARTPV:I:0)

Member Name	Type	Style	Description
CurrentFault	BOOL		Analog current measurement does not match the current the Field Device reported over HART network.
ConfigurationChanged	BOOL		The Field Device configuration has changed and new Field Device configuration information can be obtained from the 1756-IF16H module via CIP MSG GetDeviceInfo, which clears this bit.
ResponseCode	SINT	Binary	HART communication status byte or Response code from a recent HART reply. See Response Code and Field Device Status on page 229 for more information.
FieldDeviceStatus	SINT	Binary	HART device status byte from a recent HART reply. Indicates the health of the HART Field device. See Field Device Status Bit Mask Definitions on page 230 for more information.
ExtDeviceStatus	SINT	Binary	Extended device status byte. Bit 0 is Maintenance Needed. Bit 1 is Device Variable Alert. Bit 2 is Low Power.
ChxxPV (xx = 00...15)	REAL		Channel xx HART PV Value.
ChxxSV (xx = 00...15)	REAL		Channel xx HART SV Value.
ChxxTV (xx = 00...15)	REAL		Channel xx HART TV Value.
ChxxFV (xx = 00...15)	REAL		Channel xx HART FV Value.
ChxxPVStatus (xx = 00...15)	SINT		Channel xx HART PV Status. See HART PV, SV, TV, and FV Status on page 236 for more information.
ChxxSVStatus (xx = 00...15)	SINT		Channel xx HART SV Status. See HART PV, SV, TV, and FV Status on page 236 for more information.
ChxxTVStatus (xx = 00...15)	SINT		Channel xx HART TV Status. See HART PV, SV, TV, and FV Status on page 236 for more information.
ChxxFVStatus (xx = 00...15)	SINT		Channel xx HART FV Status. See HART PV, SV, TV, and FV Status on page 236 for more information.

Analog and HART by Channel

[Table 39](#) describes the input tags available in the Analog with HART Channel Grouped data format for the 1756-IF16H module.

Table 39 - 1756-IF16H Input Tags - Analog and HART by Channel (AB:1756-IF16H_AnalogHARTbyChannel:I:0)

Member Name	Type	Style	Description
ChannelFaults (bit0...15)	INT	Binary	Indicates a problem with analog data on Channel xx or broken communication between the Logix controller and the 1756-IF16H module. Example: Set if analog signal is larger than 20 mA.
ChxxFault (xx = 00...15)	BOOL		ChannelFaults.xx
ModuleStatus	SINT	Binary	
Calibrating	BOOL	Decimal	(ModuleStatus.0) Calibration in progress.
UpdatedStatusReady	BOOL	Decimal	(ModuleStatus.1) Module has collected updated Additional Device Status from HART command 48. This status can be retrieved by using the Read Additional Status service, 16#4C. For more information about this service, see Read Additional Status (Service Code = 16#4C) on page 181 .
ModuleFaults	SINT	Binary	
CalFault	BOOL		(ModuleFaults.6) 1756-IF16H module calibration failed.
AnalogGroupFault	BOOL	Decimal	(ModuleFaults.7) Indicates that a fault has occurred on any channel (any of ChannelFaults).
Chxx (xx = 00...15)	AB:1756_IF16H_HARTDataAll_Struct:I:0, Channel xx analog and HART data.		
Data	REAL	Float	Analog value in engineering units.
DeviceStatus	AB:1756_IF16H_HARTStatusAll_Struct:I:0, Channel 00 HART Device status info.		

Table 39 - 1756-IF16H Input Tags - Analog and HART by Channel (AB:1756-IF16H_AnalogHARTbyChannel:I:0)

Member Name	Type	Style	Description
HARTInit	BOOL	Decimal	Searching for or Initializing HART device. If this value is 0 and Fail is 1, then HART is not Enabled on this channel. If both are 1, then 1756-IF16H is sending out HART messages to attempt to establish communication with a HART device.
HARTCommFail	BOOL	Decimal	HART communication failure or device not found or HART not enabled. If this bit is 1, none of the other data in the HART part of the Input Tag are valid. (HART.PVStatus is also set to 0 to indicate this.)
MsgReady	BOOL	Decimal	Pass-through message reply is ready for query service.
CurrentFault	BOOL	Decimal	Analog current measurement does not match the current the Field Device reported over the HART network.
ConfigurationChanged	BOOL	Decimal	The field device configuration has changed and new field device configuration information can be obtained from the 1756-IF16H module via CIP MSG GetDeviceInfo, which clears this bit.
MaintenanceRequired	BOOL		Bit 0 of Extended Device Status (if using CMD 9, or from CMD 48 if supported).
BrokenWire	BOOL	Decimal	Indicates that current is not flowing through the module as expected. Broken wiring, RTB removal, or a powered-off field device can cause this.
HARTFault	BOOL	Decimal	Indicates a problem with HART data from the field device on Channel xx. Examples are HART not enabled, HART device not connected, HART communication failure due to noise. These Field Device Status conditions also cause this to be set: Device Malfunction, PV Out of Limits, Loop Current Saturated, and Loop Current Fixed.
ResponseCode	SINT	Binary	HART communication status byte or Response code from a recent HART reply. See Response Code and Field Device Status on page 229 for more information.
FieldDeviceStatus	SINT	Binary	HART device status byte from a recent HART reply. Indicates the health of the HART Field device. See Field Device Status Bit Mask Definitions on page 230 for more information.
AlarmStatus	SINT	Binary	Indicates various alarms on the analog signal.
DeviceVariableAlert	BOOL		AlarmStatus.4, Bit 1 of Extended Device Status. Device reports a problem with some measurement.
Overrange	BOOL		AlarmStatus.5, Signal value over range (over 20 MA).
Underrange	BOOL		AlarmStatus.6, Signal value under range. (less than 3.4 mA if configured for 4...20 mA).
CalFault	BOOL		AlarmStatus.7, Bad calibration.
PV	REAL	Float	Primary value. This is the same value as signaled on the analog channel and is the most important measurement that is made by this device.
SV	REAL	Float	Secondary value
TV	REAL	Float	Third value
FV	REAL	Float	Fourth value
PVStatus	SINT	Hex	Primary status 16#C0 = Connected 16#00 = Not Connected
SVStatus	SINT	Hex	Secondary status 16#C0 = Connected 16#00 = Not Connected
TVStatus	SINT	Hex	Third status 16#C0 = Connected 16#00 = Not Connected
FVStatus	SINT	Hex	Fourth status 16#C0 = Connected 16#00 = Not Connected
CSTimestamp	DINT[2]	Hex	Timestamp that is taken at the time the input data was sampled in terms of coordinated system time, which is a 64-bit value in microseconds coordinated across the modules in the 1756 backplane.
RollingTimestamp	INT	Decimal	Timestamp that is taken at the time the input data was sampled in millisecond resolution.

1756-IF16IH HART Analog Input Module

Topic	Page
Module Features	91
Wire the Module	97
Circuit Diagram	98
1756-IF16IH Module Fault and Status Reporting	99
Module Calibration	101
Module-defined Data Types, 1756-IF16IH Module	101

Module Features

The 1756-IF16IH module is an isolated, 16-channel, current-only input module capable of HART communication on all channels. Each channel is individually configurable.

The 1756-IF16IH module has the following features:

- 16 isolated, individually configurable input channels with a separate HART modem on each channel
- Channel-to-channel, channel-to-backplane, and channel-to-frame ground galvanic isolation at a continuous level of 250V AC rms
- Two input ranges: 0...20 mA and 4...20 mA
- Compatible tag layouts with the non-isolated 1756-IF16H module for use of the 1756-IF16IH module in existing systems:
 - 1756-IF16H compatible configuration Instance
 - 1756-IF16H compatible input data tag layouts for Analog Only, Analog and HART PV, and Analog and HART PV by Channel Grouped
- Supports full simultaneous HART 1200 baud bandwidth to all channels
- Channel ADC filter (one setting per module)
- Digital filtering (configurable per channel)
- Real-time sampling
- Auto-scanning of HART variables (PV, SV, TV, FV)
- HART pass-through interface
- User scaling of input data
- Time stamping

- Alarms and fault detection
 - Open wire detection(4...20 mA range)
 - Underrange and overrange detection
 - Fault reporting
- User Calibration via Add-on Profile
- Downloadable firmware using ControlFLASH™ software
- Add-on Profile
- “Bumpless” configuration for a smooth transition in new configurations
- Removal and insertion under power (RIUP)

HART Compatibility

The 1756-IF16IH functions as a HART master. It communicates with HART devices that have a HART revision of 5, 6, or 7. Each channel has its own HART modem and functions as a HART primary master.

The 1756-IF16IH module supports one HART device per channel.

The 1756-IF16IH module does not support burst mode, phase shift keying (PSK), or multi-drop network configuration. The module detects and turns off a bursting device at initial connection with the device.

HART Handheld Configurator

A HART handheld configuration tool can be connected to the HART device while the module is connected as long as the configuration tool is the secondary master.

Data Formats

Data format determines which values are included in the input tag of the module and the features that are available to your application. Select the data format on the General tab in the Studio 5000 Logix Designer® application.

[Table 40](#) shows the available data formats for the 1756-IF16IH module.

Table 40 - Data Formats for the 1756-IF16IH Module

Format	Description			
	Analog signal values	Analog status	HART process variables and device health	Grouped HART and analog data for each channel
Analog Only	X	X		
Analog and HART PV	X	X	X	
Analog and HART PV by Channel Grouped	X	X	X	X

- Choose Analog and HART PV if you prefer the members of your tag to be arranged similar to non-HART analog input modules. With this selection, the analog values for all channels are grouped near the end of the tag. This arrangement makes it easy to view all 16 analog values at once.
- Choose Analog and HART PV by Channel Grouped if you prefer Status, Analog Value, and Device Status for each channel to be together in the tag. This arrangement makes it easier to view all data that is related to one field device.

Input Ranges

You can select one of two input ranges for each channel on the module. The range designates the minimum and maximum signals that are detectable by the module. These are the possible ranges:

- 0...20 mA
- 4...20 mA (HART instruments use this range)

Module Filter

The module filter attenuates the input signal at the specified frequency and above. This feature is applied on a module-wide basis, which affects all channels.

The module attenuates the selected frequency by approximately -3 dB or 0.707 of the applied amplitude.

An input signal with frequencies above the selected frequency is attenuated more while frequencies below the selection receive no attenuation.

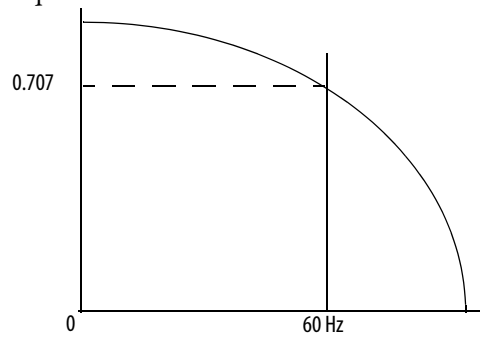

A by-product of the filter selection is the minimum available sample rate (RTS). For example, the 1000 Hz selection does not attenuate any frequencies less than 1000 Hz, and provides for sampling of all 16 channels within 11 ms. The 15 Hz selection attenuates all frequencies above 15 Hz and provides only for sampling all 16 channels within 328 ms.

IMPORTANT Do not use the 1000 Hz module filter with HART instruments.

IMPORTANT 15 Hz is the default setting for the module filter.

Use [Table 41](#) to choose a module filter setting.

Table 41 - Module Filter Selections with Associated Performance Data for 1756-IF16IH

Module Filter Setting (-3 dB)	15 Hz	20 Hz	50 Hz	60 Hz	100 Hz	250 Hz	1000 Hz
Minimum Sample Time (RTS)	328 ms	275 ms	115 ms	115 ms	61 ms	25 ms	11 ms
Effective Resolution (0...20 mA, 4...20 mA range)	18 bits	18 bits	17 bits	17 bits	16 bits	16 bits	15 bits
	0.08 μ A	0.08 μ A	0.16 μ A	0.16 μ A	0.32 μ A	0.32 μ A	0.64 μ A
-3 dB Frequency	11.5 Hz	13.8 Hz	34.5 Hz	34.5 Hz	69.0 Hz	221 Hz	1104 Hz
50 Hz Common Rejection	100 dB	—	—	—	—	—	—
50 Hz Normal Rejection	74 dB	—	—	—	—	—	—
60 Hz Normal Rejection	74 dB	97 dB	—	—	—	—	—
60 Hz Common Rejection	100 dB	100 dB	—	—	—	—	—
Channel ADC Update Rate (samples per second)	50 SPS	60 SPS	150 SPS	150 SPS	300 SPS	960 SPS	4800 SPS
Settling Time	80 ms	66.7 ms	26.7 ms	26.7 ms	13.3 ms	4.17 ms	0.83 ms

Digital Filter

The digital filter smooths input data noise transients. There is a separate digital filter for each channel.

The digital filter value specifies the time constant in milliseconds for a digital first order lag filter on the input. A value of 0 disables the filter.

The digital filter equation is a classic first order lag equation:

$$Y_n = Y_{n-1} + \frac{[\Delta t]}{\Delta t + T_A} (X_n - Y_{n-1})$$

Y_n = present output, filtered peak voltage (PV)

Y_{n-1} = previous output, filtered PV

Δt = module channel update time (seconds)

T_A = digital filter time constant (seconds)

X_n = present input, unfiltered PV

[Figure 22](#) illustrates filter response to a step input. When the digital filter time constant elapses, 63.2% of the total response is reached. Each additional time constant achieves 63.2% of the remaining response.

Figure 22 - Filter Response

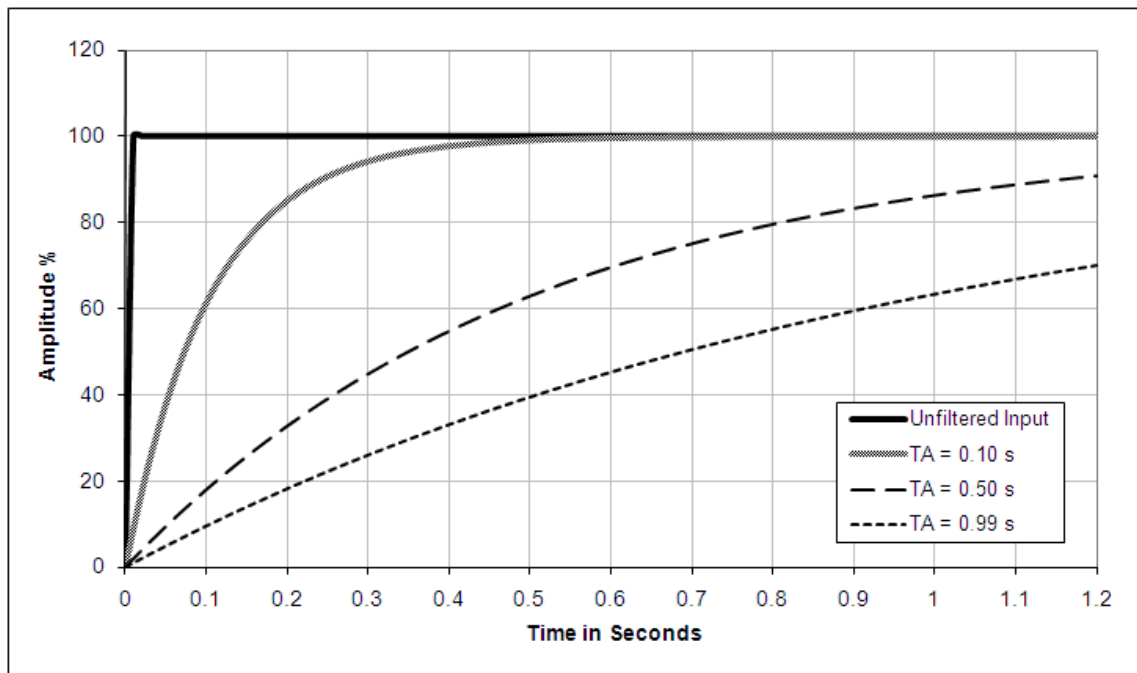

Real-time Sampling

This parameter instructs the module how often to scan its input channels and obtain new sampled data. After the channels are scanned, the module broadcasts that data (multicast or unicast) to the local chassis backplane. After the channels are scanned, the module multicasts that data. This feature is applied on a module-wide basis.

During module configuration, you specify a real-time sampling (RTS) period and a requested packet interval (RPI) period. Both of these features instruct the module to broadcast data, but only the RTS feature instructs the module to scan its channels before broadcasting.

For more RTS information, see [Real Time Sample \(RTS\) on page 23](#).

Underrange and Overrange Detection

The module detects when it is operating beyond limits of the input range. This status indication tells you that the input signal is not being measured accurately because the signal is beyond the measuring capability of the module. For example, the module cannot distinguish between 20.58...30 mA.

[Table 42](#) shows the input ranges of the 1756-IF16IH module and the lowest and highest signal available in each range before the module detects an underrange and overrange condition.

Table 42 - Low and High Signal Limits on the 1756-IF16IH Module

Input Module	Available Range	Lowest Signal in Range	Highest Signal in Range
1756-IF16IH	0...20 mA	0 mA	20.58 mA
	4...20 mA	3.42 mA	20.58 mA

Open Circuit Detection

In the 4...20 mA range, if the signal wire to a channel opens, the module reports a negative full-scale value in the input data tag of the channel within 5 seconds. The module also sets the ChxBrokenWire status bit.

In the 0...20 mA range, an open-circuit condition results in a measured value of 0 mA, which is the same as a measured value of 0 mA when there is not an open-circuit condition. The appropriate Underrange bit is set but the ChxBrokenWire bit is not set.

Wire the Module

Use this information to wire the current inputs.

Figure 23 - Current Inputs

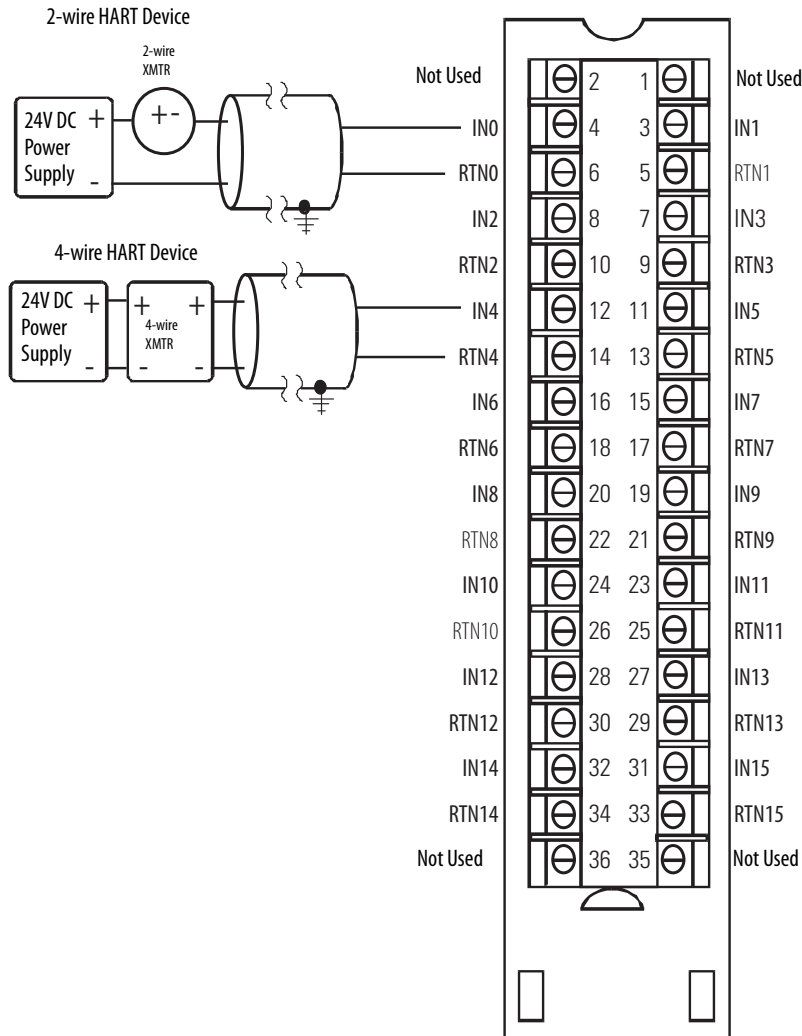

Pin #	Usage	Usage	Pin #
2	Not Used	Not Used	1
4	IN0	IN1	3
6	RTN0	RTN1	5
8	IN2	IN3	7
10	RTN2	RTN3	9
12	IN4	IN5	11
14	RTN4	RTN5	13
16	IN6	IN7	15
18	RTN6	RTN7	17
20	IN8	IN9	19
22	RTN8	RTN9	21
24	IN10	IN11	23
26	RTN10	RTN11	25
28	IN12	IN13	27
30	RTN12	RTN13	29
32	IN14	IN15	31
34	RTN14	RTN15	33
36	Not Used	Not Used	35

Circuit Diagram

This figure is a simplified input circuit diagram for the 1756-IF16IH module.

Figure 24 - 1756-IF16IH Simplified Current Input Circuit

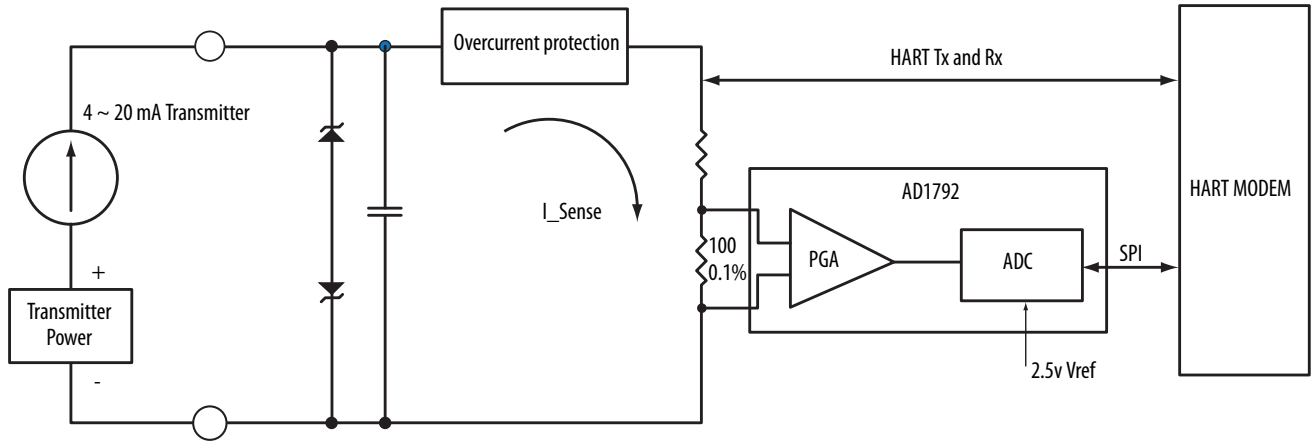

1756-IF16IH Module Fault and Status Reporting

The 1756-IF16IH module sends status/fault data to the controller with its channel data. The fault data is arranged to let you choose the level of granularity you desire for examining fault conditions. Three levels of tags work together to provide an increasing degree of detail as to the specific cause of faults on the module. [Figure 25](#) offers an overview of the fault reporting process for the 1756-IF16IH module offers an overview of how faults are reported.

Figure 25 - 1756-IF16IH Module Fault Reporting

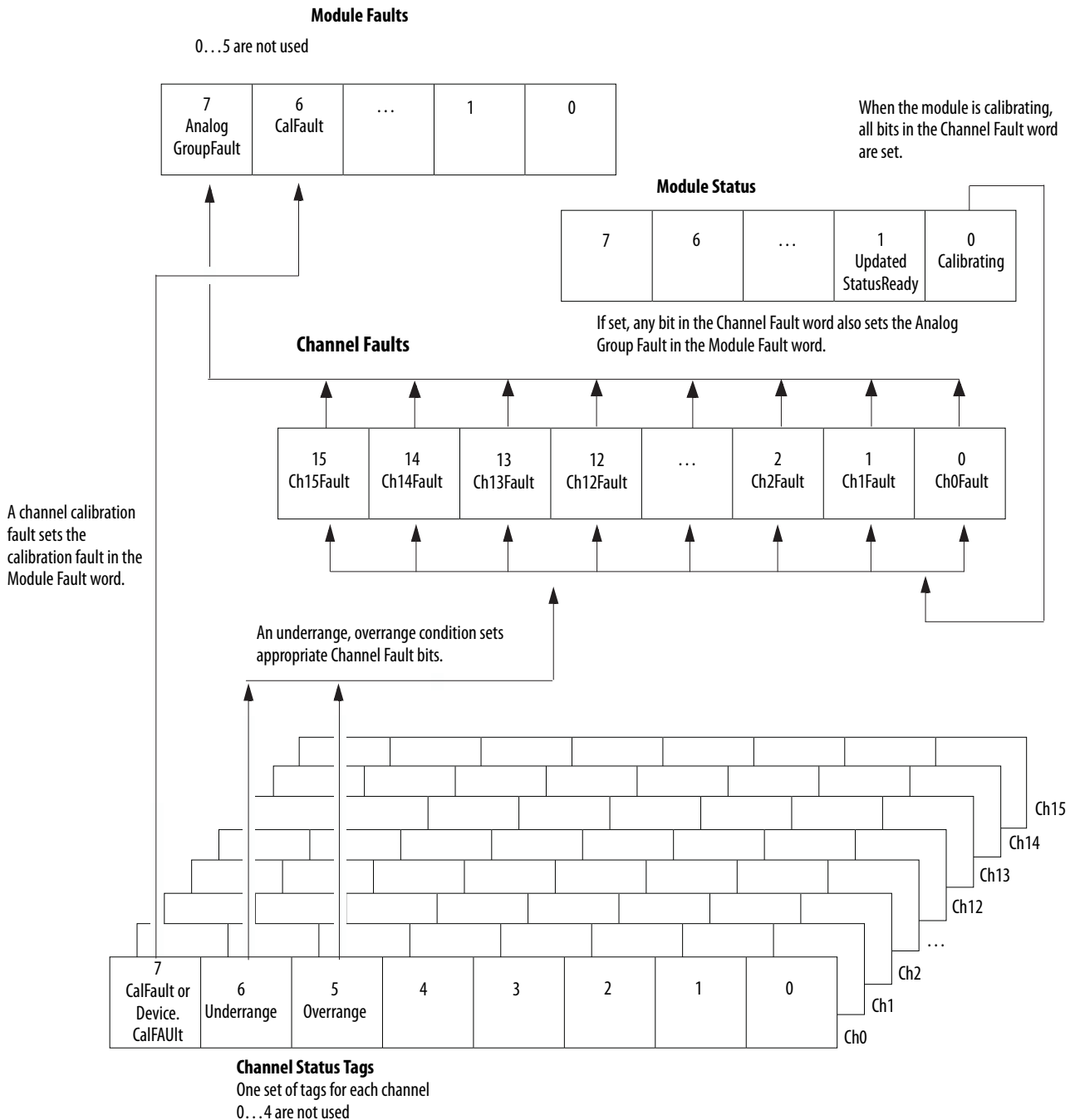

[Table 43](#) shows the tags that can be examined in ladder logic to indicate when a fault has occurred.

Table 43 - 1756-IF16IH Tags That Can Be Examined in Ladder Logic

Tag	Description	Tag Name Analog and HART PV	Tag Name Analog and HART PV by Channel Grouped
Module Fault Word	This word provides fault summary reporting.	ModuleFaults	ModuleFaults
Channel Fault Word	This word provides clamp and communication fault reporting.	ChannelFaults ChxxFault	ChannelFaults ChxxFault
Channel Status Tags	These words provide individual channel limit, hold, open wire, ramp status, and calibration faults.	ChxxStatus	Chxx.Device Status Chxx.DeviceStatus.AlarmStatus
HART Faults	This provides HART communication status.	HARTFaults, ChxxHARTFault	Chxx.DeviceStatus.HARTFault
HART Device Status	This provides HART field device health.	HART.ChxxDevice Status	Chxx.DeviceStatus.FieldDeviceStatus

1756-IF16IH Module Fault Word Bits

Bits in this word provide the highest level of fault detection. A nonzero condition in this word reveals that a fault exists on the module. You can examine further to isolate the fault. [Table 44](#) lists tags that can be examined in ladder logic to indicate when a fault has occurred.

Table 44 - 1756-IF16IH Tags That Can Be Examined in Ladder Logic

Tag	Description
Analog Group Fault	This bit is set when any bits in the Channel Fault word are set. Its tag name is AnalogGroupFault.
Calibration Fault	This bit is set when any of the individual Channel Calibration Fault bits are set. Its tag name is CalFault.

1756-IF16IH Channel Fault Tags

During normal module operation, bits in the Channel Fault word are set if any of the respective channels has an Under or Overrange condition. Checking this word for a nonzero value is a quick way to check for Under or Overrange conditions on the module.

Table 45 - 1756-IF16IH Conditions That Set All Channel Fault Word Bits

This Condition Sets All Channel Fault Word Bits	And Causes the Module to Display the Following in the Channel Fault Word Bits
A channel is being calibrated	16#00FF
A communication fault occurred between the module and its owner-controller	16#FFFF

1756-IF16IH Channel Status Tags

[Table 46](#) describes the channel status tags.

Table 46 - 1756-IF16IH Tags That Show Channel Status⁽¹⁾

Tag	Bit	Description
ChxCalFault	7	This bit is set if an error occurs during calibration for Channel <i>x</i> , which causes a bad calibration. Also sets CalFault in the Module Faults.
ChxUnderrange	6	This bit is set when the analog signal is less than or equal to the minimum detectable signal. Because the signal cannot be measured, it can be significantly below the minimum value. Also sets ChxxFault in the Channel Faults.
ChxOverrange	5	This bit is set when the analog signal is greater than or equal to the maximum detectable signal. Because the signal cannot be measured, it can be significantly above the maximum value. Also sets ChxxFault in the Channel Faults.

(1) Bits 0...4 are not used.

Module Calibration

You can initiate calibration of the 1756-IF16IH module via the Logix Designer application Calibration tab.

The Calibration tab in the Logix Designer application provides a button to initiate module calibration and a display of the results. See [Calibration Tab on page 170](#) for more information.

Module-defined Data Types, 1756-IF16IH Module

[Table 47](#)...[Table 51](#) describe module-defined data types for the 1756-IF16IH module and include information for configuration and input tags.

Available tags depend on the selected input data format, as shown in [Table 47](#).

Table 47 - 1756-IF16IH Input Data Choice and Tags

Input Data Choice	Tag	Main Module Defined Type	Subtype Used by Main Type
Analog Only	Configuration	AB:1756_IF16IH:C:0	AB:1756_IF16IH_ChConfig_Struct:C:0
	Input	AB:1756_IF16IH_Analog:I:0	None
Analog and HART PV	Configuration	AB:1756_IF16IH:C:0	AB:1756_IF16IH_ChConfig_Struct:C:0
	Input	AB:1756_IF16IH_HARTPV:I:1	AB:1756_IF16IH_HARTData:I:1 AB:1756_IF16IH_HARTStatus_Struct:I:1
Analog and HART PV by Channel Grouped	Configuration	AB:1756_IF16IH:C:0	AB:1756_IF16IH_ChConfig_Struct:C:0
	Input	AB:1756_IF16IH_AnalogHARTbyChannel:I:0	AB:1756_IF16IH_HARTDataAll_1_Struct:I:0 AB:1756_IF16IH_HARTStatusAll_1_Struct:I:0

Configuration

[Table 48](#) describes the configuration tags available for the 1756-IF16IH module.

Table 48 - 1756-IF16IH Configuration Tags (AB:1756_IF16IH:C:0)

Member Name	Type	Style	Description
ModuleFilter (bits 0...7)	SINT	Decimal	See the Module Filter Selections with Associated Performance Data for 1756-IF16IH table on page 94 .
RealTimeSample (bits 0...15)	INT	Decimal	Milliseconds between reading signal values. See Real-time Sampling on page 96 for more information.
ChxxConfig (xx = 00...15)	AB:1756_IF16IH_ChConfig_Struct:C:0		
Config	SINT	Binary	
HARTen	BOOL	Decimal	ChxxConfig.Config.7, Enable HART communication. Must be 1 for valid HART data in input tag and asset management access to HART field device.
RangeType	SINT	Decimal	0 = 0...20 mA 1 = 4...20 mA
DigitalFilter	INT	Decimal	Time constant of low pass filter in ms. See Digital Filter on page 95 for more information.
LowSignal	REAL	Float	Lower current value for scaling to engineering units. Default is 4 mA. Must be less than HighSignal and more than or equal to the minimum input range. See Scaling to Engineering Units on page 153 for more information.
HighSignal	REAL	Float	Upper current value for scaling to engineering units. Default is 20 mA. Must be more than LowSignal and less than or equal to the maximum input Range. See Scaling to Engineering Units on page 153 for more information.
LowEngineering	REAL	Float	Measured quantity in engineering units that results in a signal level equal to LowSignal. See Scaling to Engineering Units on page 153 for more information.
HighEngineering	REAL	Float	Measured quantity in engineering units that results in a signal level equal to HighSignal. See Scaling to Engineering Units on page 153 for more information.
CalBias	REAL	Float	Sensor Offset in engineering units added to the measured signal before reporting Chxx.Data.
PassthroughHandle Timeout	INT	Decimal	Seconds to keep a reply to a HART pass-through service request before discarding; 15 seconds is recommended.

Analog Only

[Table 49](#) describes the input tags available in the Analog Only data format for the 1756-IF16IH module.

Table 49 - 1756-IF16IH Input Tags - Analog Only (AB:1756_IF16IH_Analog:I:0)

Member Name	Type	Style	Description
ChannelFaults (bits 0 ... 15)	INT	Binary	Indicates a problem with analog data on Channel x or broken communication between the Logix controller and the 1756-IF16IH module. Example: Set if analog signal is larger than 20 mA.
ChxxFault (xx = 00 ... 15)	BOOL	Decimal	ChannelFaults.0 ... ChannelFaults.15
Module Status	SINT	Binary	
Calibrating	BOOL		ModuleStatus.0, Calibration in progress
UpdatedStatusReady	BOOL		ModuleStatus.1, Module has collected updated Additional Device Status from HART command 48. This status can be retrieved by using the Read Additional Status service, 16#4C. For more information about this service, see Read Additional Status (Service Code = 16#4C) on page 181 .
ModuleFaults	SINT	Binary	Module level fault status bits (bits 0 ... 5 not used)
CalFault	BOOL	Decimal	(ModuleFaults.6) 1756-IF16IH Module Calibration Failed.
AnalogGroupFault	BOOL	Decimal	(ModuleFaults.7) Indicates that a fault has occurred on any channel (any of ChannelFaults).
BrokenWireFaults (bit 0 ... 15)	INT	Binary	Indicates that current is not flowing through the module as expected. Broken wiring, RTB removal, or a powered-off field device can cause this. If configured for 4 ... 20 mA, a broken wire fault sets this bit.
ChxxBroken Wire	BOOL	Decimal	BrokenWireFaults.0 ... BrokenWireFaults.15
HARTFaults (Ch00 ... Ch15)	INT	Binary	Indicates a problem with HART data from the Field Device on Channel x. Examples are HART not enabled, HART device not connected, HART communication failure due to noise. These Field Device Status conditions also cause this to be set: Device Malfunction, PV Out of Limits, Loop Current Saturated, and Loop Current Fixed.
ChxxHARTFault	BOOL	Decimal	HARTFaults.0 ... HARTFaults.15
ChxxStatus (xx = 00 ... 15)	SINT	Binary	Indicates various alarms on the analog signal. Also sets ChxxFault.
ChxxOverrange	BOOL		ChxxStatus.5 Analog signal is greater than or equal to the maximum detectable signal. Because the signal cannot be measured, it can be significantly above the maximum value.
ChxxUnderrange	BOOL		ChxxStatus.6 Analog signal is less than or equal to the minimum detectable signal. Because the signal cannot be measured, it can be significantly below the minimum value.
ChxxCalFault	BOOL		ChxxStatus.7 Set if an error occurs during calibration for Chxx, which causes a bad calibration. Also sets CalFault.
ChxxData (xx = 00 ... 15)	REAL	Float	Value of analog signal on Channel xx after conversion to engineering units.
CSTimestamp	DINT[2]	Hex	Timestamp that is taken at the time the input data was sampled in terms of Coordinated System Time, which is a 64-bit value in microseconds coordinated across the modules in the 1756 backplane.
RollingTimestamp	INT	Decimal	Timestamp that is taken at the time the input data was sampled in millisecond resolution.

Analog and HART PV

Table 50 describes the input tags available in the Analog and HART PV data format for the 1756-IF16IH module.

Table 50 - 1756-IF16IH Input Tags - Analog and HART PV (AB:1756_IF16IH_HARTPV:I:0)

Member Name	Type	Style	Description
ChannelFaults (bit0...15)	INT	Binary	Indicates a problem with analog data on Channel x or broken communication between the Logix controller and the 1756-IF16IH module. Example: Set if analog signal is larger than 20 mA.
ChxxFault (xx = 00...15)	BOOL	Decimal	ChannelFaults.0...ChannelFaults.15
Module Status	SINT	Binary	
Calibrating	BOOL		(ModuleStatus.0) Calibration in progress.
UpdatedStatusReady	BOOL		(ModuleStatus.1) Module has collected updated Additional Device Status from HART command 48. This status can be retrieved by using the Read Additional Status service, 16#4C. For more information about this service, see Read Additional Status (Service Code = 16#4C) on page 181 .
ModuleFaults	SINT	Binary	(bits0...5 not used)
CalFault	BOOL	Decimal	(ModuleFaults.6) 1756-IF16IH Module Calibration Failed.
AnalogGroupFault	BOOL	Decimal	(ModuleFaults.7) Indicates that a fault has occurred on any channel (any of ChannelFaults).
BrokenWireFaults (bit 0...15)	INT	Binary	Indicates that current is not flowing through the module as expected. Broken wiring, RTB removal, or a powered-off field device can cause this.
ChxxBroken Wire	BOOL	Decimal	BrokenWireFaults.0...BrokenWireFaults.15
HARTFaults	INT	Binary	Indicates a problem with HART data from the Field Device on Channel x. Examples are HART not enabled, HART device not connected, HART communication failure due to noise. These Field Device Status conditions also cause this to be set: Device Malfunction, PV Out of Limits, Loop Current Saturated, and Loop Current Fixed.
ChxxHARTFault	BOOL	Decimal	HARTFaults.0...HARTFaults.15
ChxxStatus (xx = 00...15)	SINT	Binary	Indicates various alarms on the analog signal. Also sets ChxxFault for Overrange, Underrange, and/or CalFault.
ChxxOverrange	BOOL		(ChxxStatus.05) Analog signal is greater than or equal to the maximum detectable signal. Because the signal cannot be measured, it can be significantly above the maximum value.
ChxxUnderrange	BOOL		(ChxxStatus.06) Analog signal is less than or equal to the minimum detectable signal. Because the signal cannot be measured, it can be significantly below the minimum value.
ChxxCalFault	BOOL		(ChxxStatus.07) Set if an error occurs during calibration for Channel x, which causes a bad calibration. Also sets CalFault.
ChxxData (xx = 00...15)	REAL	Float	Value of analog signal on Channel xx after conversion to engineering units.
CSTimestamp	DINT[2]	Hex	Timestamp that is taken at the time the input data was sampled in terms of Coordinated System Time, which is a 64-bit value in microseconds coordinated across the modules in the 1756 backplane.
RollingTimestamp	INT	Decimal	Timestamp that is taken at the time the input data was sampled in millisecond resolution.
HART	AB:1756_IF16IH_HARTData:I:0, Contains HART field device health and dynamic process variables.		
ChxxDeviceStatus (xx = 00...15)	AB:1756_IF16IH_HARTStatus_Struct:I:0, Channel 0 HART Device status info.		
Init	BOOL		Searching for or Initializing HART device. If this value is 0 and Fail is 1, then HART is not Enabled on this channel. If both are 1, then 1756-IF16IH is sending out HART messages to attempt to establish communication with a HART device.
Fail	BOOL		HART communication failure or device not found or HART not enabled. If this bit is 1, none of the other data in the HART part of the Input Tag are valid. (HART.PVStatus is also set to 0 to indicate this.)
MsgReady	BOOL		Pass-through message reply is ready for Query service.

Table 50 - 1756-IF16IH Input Tags - Analog and HART PV (AB:1756_IF16IH_HARTPV:I:0)

Member Name	Type	Style	Description
CurrentFault	BOOL		Analog current measurement does not match the current the Field Device reported over HART network.
ConfigurationChanged	BOOL		The Field Device configuration has changed and new Field Device configuration information can be obtained from the 1756-IF16IH module via CIP MSG GetDeviceInfo, which clears this bit.
ResponseCode	SINT	Binary	HART communication status byte or Response code from a recent HART reply. See Response Code and Field Device Status on page 229 for more information.
FieldDeviceStatus	SINT	Binary	HART device status byte from a recent HART reply. Indicates the health of the HART Field device. See Field Device Status Bit Mask Definitions on page 230 for more information.
ExtDeviceStatus	SINT	Binary	Extended device status byte. Bit 0 is Maintenance Needed. Bit 1 is Device Variable Alert. Bit 2 is Low Power.
ChxxPV (xx = 00...15)	REAL		Channel xx HART PV Value.
ChxxSV (xx = 00...15)	REAL		Channel xx HART SV Value.
ChxxTV (xx = 00...15)	REAL		Channel xx HART TV Value.
ChxxFV (xx = 00...15)	REAL		Channel xx HART FV Value.
ChxxPVStatus (xx = 00...15)	SINT		Channel xx HART PV Status. See HART PV, SV, TV, and FV Status on page 236 for more information.
ChxxSVStatus (xx = 00...15)	SINT		Channel xx HART SV Status. See HART PV, SV, TV, and FV Status on page 236 for more information.
ChxxTVStatus (xx = 00...15)	SINT		Channel xx HART TV Status. See HART PV, SV, TV, and FV Status on page 236 for more information.
ChxxFVStatus (xx = 00...15)	SINT		Channel xx HART FV Status. See HART PV, SV, TV, and FV Status on page 236 for more information.

Analog and HART PV by Channel Grouped

[Table 51](#) describes the input tags available in the Analog and HART PV by Channel Grouped data format for the 1756-IF16IH module.

Table 51 - 1756-IF16IH Input Tags - Analog and HART PV by Channel Grouped (AB:1756-IF16IH_AnalogHARTbyChannel:I:0)

Member Name	Type	Style	Description
ChannelFaults	INT	Binary	Indicates a problem with analog data on Channel xx or broken communication between the Logix controller and the 1756-IF16IH module. Example: Set if analog signal is larger than 20 mA.
ChxxFault (xx = 00...15)	BOOL		ChannelFaults.xx
ModuleStatus	SINT	Binary	
Calibrating	BOOL	Decimal	(ModuleStatus.0) Calibration in progress.
UpdatedStatusReady	BOOL	Decimal	(ModuleStatus.1) Module has collected updated Additional Device Status from HART command 48. This status can be retrieved by using the Read Additional Status service, 16#4C. For more information about this service, see Read Additional Status (Service Code = 16#4C) on page 181 .
ModuleFaults	SINT	Binary	
CalFault	BOOL		(ModuleFaults.6) 1756-IF16IH module calibration failed.
AnalogGroupFault	BOOL	Decimal	(ModuleFaults.7) Indicates that a fault has occurred on any channel (any of ChannelFaults).
Chxx (xx = 00...15)	AB:1756_IF16IH_HARTDataAll_Struct:I:0		Channel xx analog and HART data.
Data	REAL	Float	Analog value in engineering units.

Table 51 - 1756-IF16IH Input Tags - Analog and HART PV by Channel Grouped (AB:1756-IF16IH_AnalogHARTbyChannel:I:0)

Member Name	Type	Style	Description
DeviceStatus	AB:1756_IF16IH_HARTStatusAll_Struct:I:0, Channel 00 HART Device status info.		
HARTInit	BOOL	Decimal	Searching for or Initializing HART device. If this value is 0 and Fail is 1, then HART is not Enabled on this channel. If both are 1, then 1756-IF16IH is sending out HART messages to attempt to establish communication with a HART device.
HARTCommFail	BOOL	Decimal	HART communication failure or device not found or HART not enabled. If this bit is 1, none of the other data in the HART part of the Input Tag are valid. (HART.PVStatus is also set to 0 to indicate this.)
MsgReady	BOOL	Decimal	Pass-through message reply is ready for query service.
CurrentFault	BOOL	Decimal	Analog current measurement does not match the current the Field Device reported over the HART network.
ConfigurationChanged	BOOL	Decimal	The field device configuration has changed and new field device configuration information can be obtained from the 1756-IF16IH module via CIP MSG GetDeviceInfo, which clears this bit.
MaintenanceRequired	BOOL		Bit 0 of Extended Device Status (if using CMD 9, or from CMD 48 if supported).
BrokenWire	BOOL	Decimal	Indicates that current is not flowing through the module as expected. Broken wiring, RTB removal, or a powered-off field device can cause this.
HARTFault	BOOL	Decimal	Indicates a problem with HART data from the field device on Channel xx. Examples are HART not enabled, HART device not connected, HART communication failure due to noise. These Field Device Status conditions also cause this to be set: Device Malfunction, PV Out of Limits, Loop Current Saturated, and Loop Current Fixed.
ResponseCode	SINT	Binary	HART communication status byte or Response code from a recent HART reply. See Response Code and Field Device Status on page 229 for more information.
FieldDeviceStatus	SINT	Binary	HART device status byte from a recent HART reply. Indicates the health of the HART Field device. See Field Device Status Bit Mask Definitions on page 230 for more information.
AlarmStatus	SINT	Binary	Indicates various alarms on the analog signal.
DeviceVariableAlert	BOOL		AlarmStatus.4, Bit 1 of Extended Device Status. Device reports a problem with some measurement.
Overrange	BOOL		AlarmStatus.5, Signal value over range (over 20 mA).
Underrange	BOOL		AlarmStatus.6, Signal value under range. (less than 3.4 mA if configured for 4...20 mA).
CalFault	BOOL		AlarmStatus.7, Bad calibration.
PV	REAL	Float	Primary value. This is the same value as signaled on the analog channel and is the most important measurement that is made by this device.
SV	REAL	Float	Secondary value
TV	REAL	Float	Third value
FV	REAL	Float	Fourth value
PVStatus	SINT	Hex	Primary status 16#C0 = Connected 16#00 = Not Connected
SVStatus	SINT	Hex	Secondary status 16#C0 = Connected 16#00 = Not Connected
TVStatus	SINT	Hex	Third status 16#C0 = Connected 16#00 = Not Connected
FVStatus	SINT	Hex	Fourth status 16#C0 = Connected 16#00 = Not Connected
CSTimestamp	DINT[2]	Hex	Timestamp that is taken at the time the input data was sampled in terms of coordinated system time, which is a 64-bit value in microseconds coordinated across the modules in the 1756 backplane.
RollingTimestamp	INT	Decimal	Timestamp that is taken at the time the input data was sampled in millisecond resolution.

1756-OF8H HART Analog Output Module

This chapter discusses these topics.

Topic	Page
Module Features	107
Wire the Module	111
Use Module Block and Output Circuit Diagrams	112
1756-OF8H Module Fault and Status Reporting	113
1756-OF8H Fault Reporting	114
Module-defined Data Types, 1756-OF8H Module	117

Module Features

The 1756-OF8H module has the following features:

- Choice of three data formats
 - Analog only
 - Analog and HART PV
 - Analog and HART by channel

IMPORTANT The Analog and HART by Channel data type is available **only** for 1756-OF8H firmware revision 2.001

- 15-bit or 16-bit resolution
- Ramping and rate limiting
- Hold for initialization
- Open wire detection
- Clamping and limited
- Clamp and limit alarms
- Data echo

Data Formats

Data format determines which values are included in the Input tag of the module and the features that are available to your application. Select the data format on the General tab in the Studio 5000 Logix Designer® application. The following data formats are available for the 1756-OF8H module.

Format	Description			
	Analog signal values	Analog status	HART secondary process variables and device health	HART and Analog data for each channel grouped together in tag
Analog Only	X	X		
Analog and HART PV	X	X	X	
Analog and HART by Channel ⁽¹⁾	X	X	X	X

(1) Available only for 1756-OF8H firmware revision 2.001.

- Choose Analog and HART PV if you prefer the members of the tag to be arranged similar to non-HART analog input modules. With this selection, analog values for all channels grouped near the end of the tag. This arrangement makes it easy to view all eight analog values at once.
- Choose Analog and HART by Channel if you prefer Status, Analog Value, and Device Status for each channel to be together in the tag. This arrangement makes it easier to view all data that is related to one field device.

Resolution

The output module can use 15-bit or 16-bit resolution.

Number of Significant Bits	Range	Resolution
16 bits	+/- 10.4V	320 μ V
15 bits	0...20 mA 4...20 mA	0.65 μ A

Ramping/Rate Limiting

Output ramping limits the speed at which an analog output signal can change. This feature prevents fast transitions in the output from damaging the devices that an output module controls. Ramping is also known as **rate limiting**.

[Table 52](#) describes the types of ramping that are possible.

Table 52 - 1756-OF8H Types of Ramping

Type of Ramping	Description
Run mode ramping	This type of ramping occurs when the module is in Run mode and limits the rate at which the output changes from one commanded value to another.
Ramp-to-Program mode	This type of ramping occurs when the controller is placed in the Program mode. The present output value changes to the Program Value. If the connection to the module is inhibited, the Program mode value and ramp rate are applied.
Ramp-to-Fault mode	This type of ramping occurs when there is a communication or controller fault. The output signal changes to the fault value after a communication fault occurs.

The maximum rate of change in outputs is expressed in engineering units per second and called the **maximum ramp rate**.

For more information about ramp rate, see [Chapter 9, Configure Modules in the Logix Designer Application](#), which describes how you can set Ramp Rate on the output Limits dialog box.

Hold for Initialization

Hold for Initialization causes outputs to hold present state until the value that the controller commands matches the value at the output terminal within 0.1% of full scale. This feature helps provide a bumpless transfer.

If Hold for Initialization is selected, outputs hold if any of these conditions occur:

- Initial connection is established after powerup.
- A new connection is established after a communication fault occurs.
- There is a transition to Run mode from Program state.

The ChxInHold bit for a channel indicates that the channel is holding.

Open Wire Detection

This feature detects when current flow is not present at any channel. The 1756-OF8H module must be configured for 0...20 mA or 4...20 mA operation to use this feature. At least 0.1 mA of current must be flowing from the output for detection to occur.

When an open wire condition occurs at any channel, a status bit named ChxOpenWire is set for that channel.

Clamping and Limiting

The clamping feature limits the output from the analog module to remain within a range that the controller configures, even when the controller commands an output outside that range. This safety feature sets a high clamp and a low clamp.

Once clamps are set for a channel, any data that is received from the controller that exceeds the clamps sets a limit alarm and transitions the output to that limit but not beyond the configured clamp value. For example, suppose that an application sets the high clamp on a module for 8V and the low clamp for -8V. If a controller sends a value that corresponds to 9V to the module, the module applies only 8V to its screw terminals. The signal value that is applied is reflected in the Input Tag ChxData field.

Clamping limits are entered in engineering units.

Clamp and Limit Alarms

This function works directly with clamping. When a module receives a data value from the controller that exceeds clamping limits, it applies the clamping limit to the signal value and sends a status bit to the controller, notifying it that the commanded output data value exceeds the clamping limits.

For example, if a channel has clamping limits of 8V and -8V but receives data to apply 9V, the module applies 8V to the screw terminals and sends a status bit to the controller. This status bit informs the controller that the 9V value exceeds the channel clamping limits.

Clamping alarms can be disabled or latched on a per channel basis. Clamping limits are entered in engineering units.

Data Echo

Data Echo automatically multicasts channel data values that match the analog value that is applied to the module screw terminals.

Fault and status data are also sent. If selected in the Input Data format, HART secondary process variables and device health are also sent.

An example is that I.ChxDData is the echo of O.ChxDData. The values can differ due to Ramp, Clamp, or Hold for Initialization.

The echo value is the current level being attempted. If the wire is off or damaged, the actual current can be 0.

Wire the Module

Use [Figure 26](#) to wire the module. Voltage outputs use the terminal block pins labeled VOUT-# and RTN. Current outputs use the terminal block pins labeled IOUT-# and RTN.

HART communication is active with current outputs only.

Figure 26 - Wiring Diagram for the 1756-0F8H Module

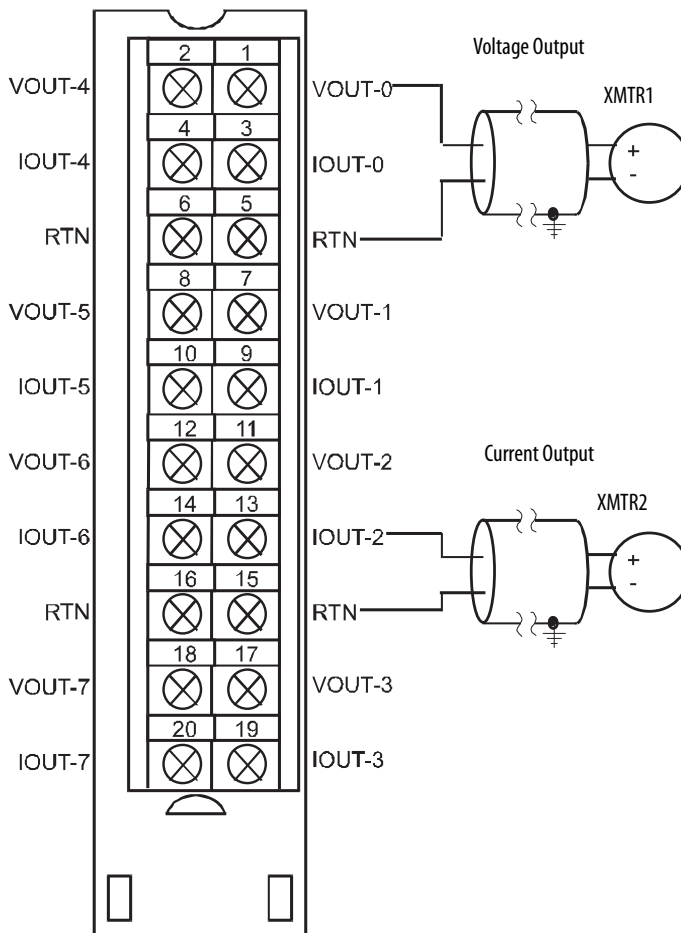

Use Module Block and Output Circuit Diagrams

Figure 27 shows the module output circuit diagram.

Figure 27 - 1756-OF8H Output Circuit Diagram

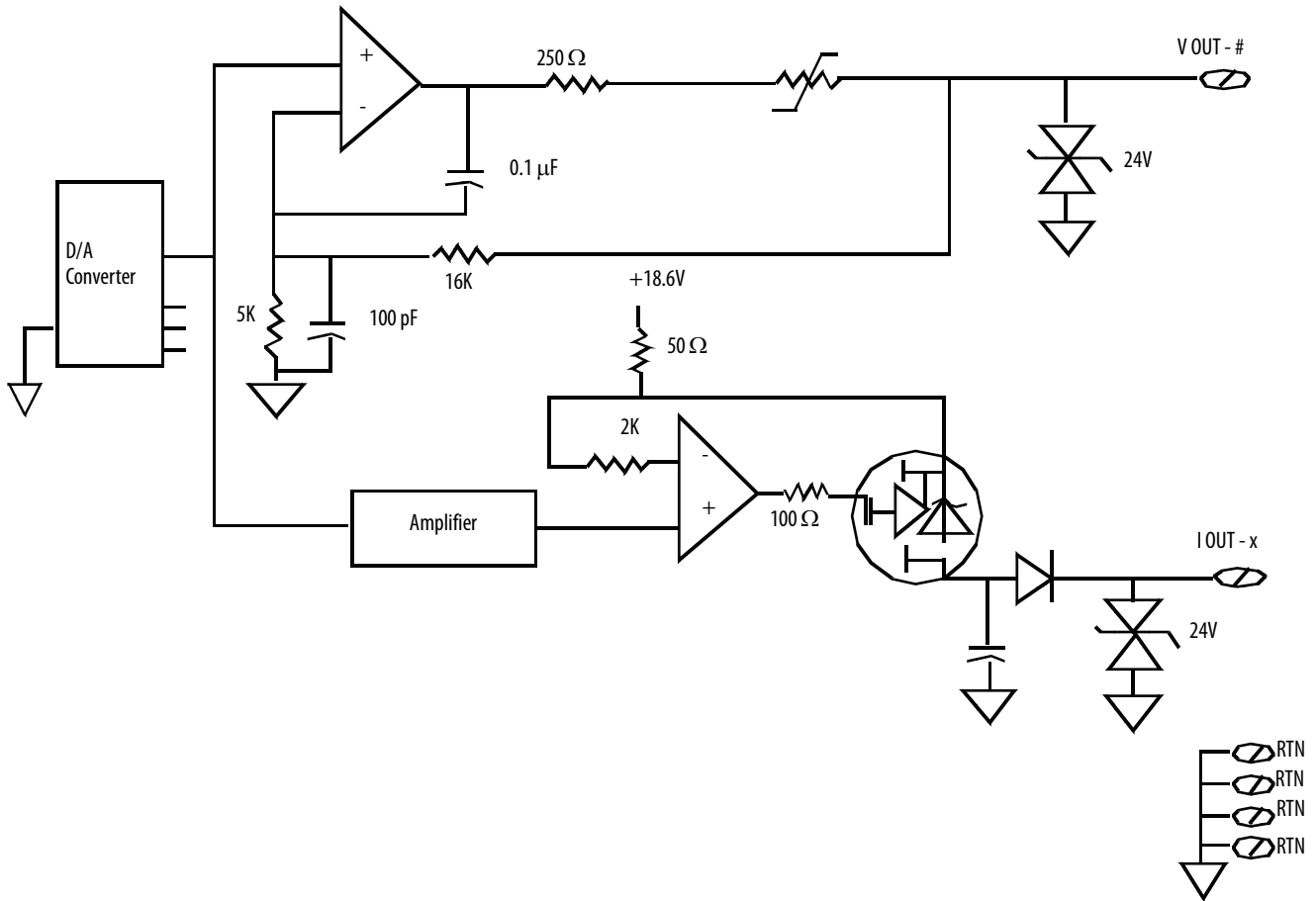

1756-OF8H Module Fault and Status Reporting

The 1756-OF8H modules multicast status and fault data to the controller with their channel data. The fault data is arranged to let you choose the level of granularity you desire for examining fault conditions.

Three levels of tags work together to provide increasing degree of detail as to the specific cause of faults on the module.

[Table 53](#) lists tags that you can examine in ladder logic to indicate when a fault occurred.

Table 53 - 1756-OF8H Tags That Can Be Examined in Ladder Logic

Tag	Description	Tag Name Analog and HART PV	Tag Name Analog and HART by Channel ⁽¹⁾
Module Fault Word	This word provides fault summary reporting.	ModuleFaults	ModuleFaults
Channel Fault Word	This word provides clamp and communication fault reporting.	ChannelFaults ChxFault	ChannelFaults ChxFault
Channel Status Tags	These words, one per channel, provide individual channel limit, hold, open wire, ramp status, and calibration faults.	ChxStatus	Chx.DeviceStatus Chx.DeviceStatus.AlarmStatus
HART Faults	This provides HART communication status.	HARTFaults, ChxHARTFault	Chx.DeviceStatus.HARTFault
HART Device Status	This provides HART field device health.	HART.ChxDevice Status	Chx.DeviceStatus.FieldDeviceStatus

(1) Available only for 1756-OF8H firmware revision 2.001.

1756-OF8H Fault Reporting

Figure 28 offers an overview of the fault reporting process.

Figure 28 - 1756-OF8H Module Fault Reporting

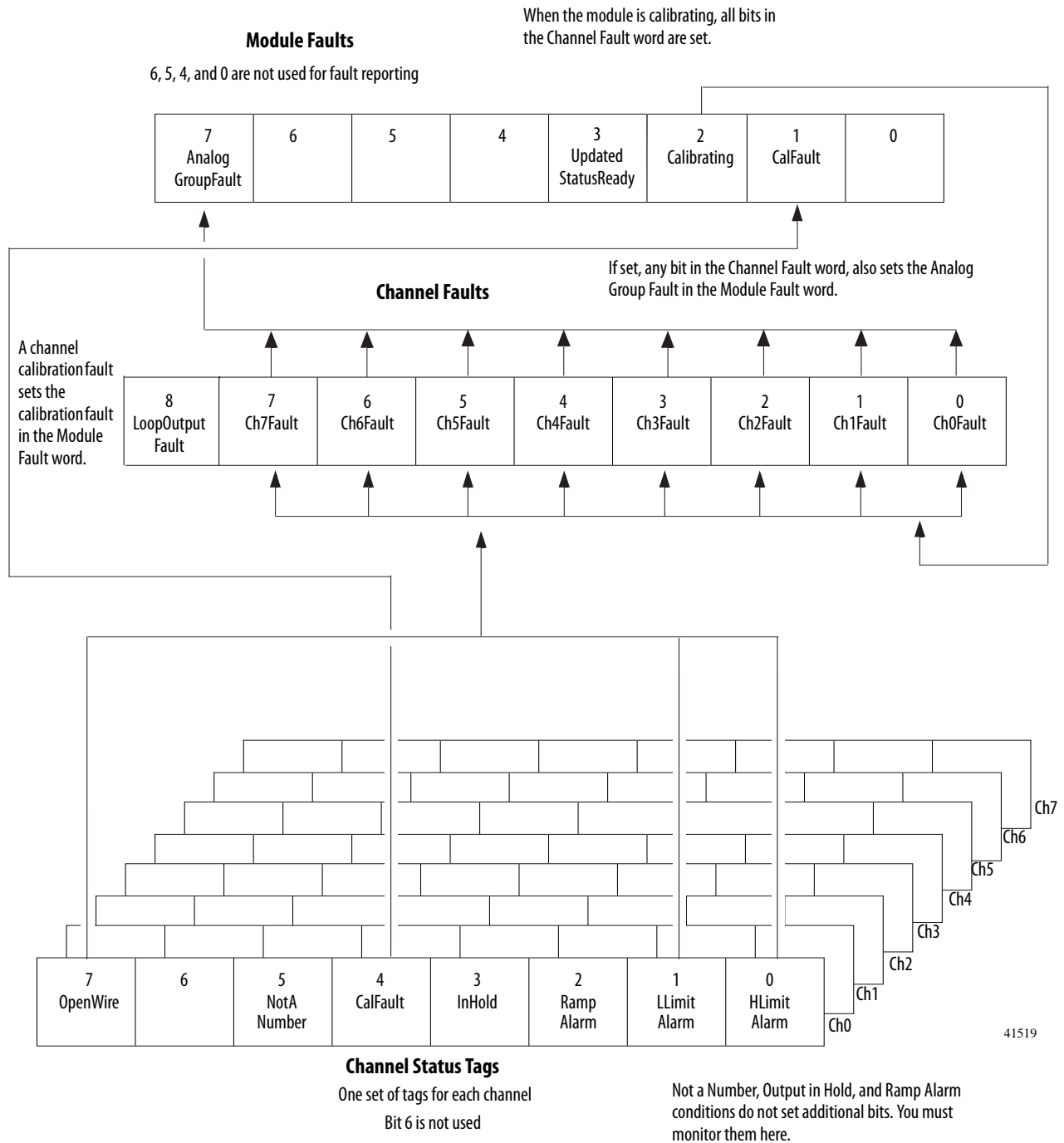

Module Fault Word Bits

Bits in this word provide the highest level of fault detection. A nonzero condition in this word reveals that a fault exists on the module. You can examine further down to isolate the fault.

[Table 54](#) lists tags that are found in the Module Fault word.

Table 54 - 1756-OF8H Tags Found in the Module Fault Word

Tag	Description	Tag Name
Analog Group Fault	This bit is set when any bits in the Channel Fault word are set.	AnalogGroupFault
Calibrating	This bit is set when any channel is being calibrated. When this bit is set, all bits in the Channel Fault word are set.	Calibrating
Calibration Fault	This bit is set when any of the individual Channel Calibration Fault bits are set.	CalFault

Channel Fault Word Bits

During normal module operation, bits in the Channel Fault word are set if any of the respective channels has a High or Low Limit Alarm or an Open Wire condition (0...20 mA or 4...20 mA configurations only). When using the Channel Fault Word, the 1756-OF8H module uses bits 0...7. Checking this word for a nonzero condition is a quick way to check for these conditions on a channel.

[Table 55](#) lists the conditions that set **all** Channel Fault word bits.

Table 55 - 1756-OF8H Conditions That Set All Channel Fault Word Bits

This Condition Sets All Channel Fault Word Bits	And Causes the Module to Display the Following in the Channel Fault Word Bits
A channel is being calibrated	16#00FF
A communication fault occurred between the module and its owner-controller	1#FFFF

Your logic monitors the Channel Fault bit for a particular output under the following conditions:

- You enable output clamping
- You are checking for an open wire condition (0...20 mA configuration only)
- You must know if the output module is not communicating with the controller

Your logic can use the bit in Channel Faults, for example, Ch2Fault, to take failure recovery action, such as signaling CVFault on a PIDE function block.

Channel Status Tags

Any of the channel status words (eight words for 1756-OF8H modules), one for each channel, display a nonzero condition if that particular channel has faulted. Some of these bits set bits in other Fault words.

When the High or Low Limit Alarm bits (ChxHLimitAlarm or ChxLLimitAlarm) in any of the words are set, the appropriate bit is set in the Channel Fault word.

When the Calibration Fault bit (CalFault) is set in any of the words, the Calibration Fault bit (bit 11) is set in the Module Fault word. [Table 56](#) lists the conditions that set each of the word bits.

Table 56 - 1756-OF8H Conditions That Set Each of the Word Bits⁽¹⁾

Tag (status words)	Bit	Event That Sets This Tag
ChxOpenWire Chx.DeviceStatus.OpenWire	7	This bit is set only if the configured Output Range is 0...20 or 4...20 mA. The circuit must also become open due to a wire falling off or being cut when the output being driven is above 0.1 mA. The bit remains set until correct wiring is restored.
ChxNotaNumber ⁽²⁾ Chx.DeviceStatus.NotANumber	5	This bit is set when the output value that is received from the controller is NotANumber (the IEEE NaN value). The output channel holds its last state.
ChxCalFault Chx.DeviceStatus.CalFault	4	This bit is set when an error occurred when calibrating. This bit also sets the appropriate bit in the Channel Fault word.
ChxInHold ⁽²⁾ Chx.DeviceStatus.InHold	3	This bit is set when the output channel is holding. The bit resets when the requested Run mode output value is within 0.1% of full-scale of the current echo value.
ChxRampAlarm ⁽²⁾ Chx.DeviceStatus.RampAlarm	2	This bit is set when the requested rate of change of the output channel exceeds the configured maximum ramp rate requested parameter. It remains set until the output reaches its target value and ramping stops. If the bit is latched, it remains set until it is unlatched.
ChxLLimitAlarm Chx.DeviceStatus.LLimitAlarm	1	This bit is set when the requested output value is beneath the configured low limit value. It remains set until the requested output is above the low limit. If the bit is latched, it remains set until it is unlatched.
ChxHLimitAlarm Chx.DeviceStatus.HLimitAlarm	0	This bit is set when the requested output value is above the configured high limit value. It remains set until the requested output is below the high limit. If the bit is latched, it remains set until it is unlatched.

(1) Bit 6 is not used.

(2) This bit does not set additional bits at any higher level.

■ Module-defined Data Types, 1756-OF8H Module

[Table 57](#)...[Table 62](#) describe module-defined data types for the 1756-OF8H module and include information for configuration, input, and output tags. Available tags depend on the selected input data format, as shown in [Table 57](#).

Table 57 - 1756-OF8H Input Data Choice and Tags

Input Data Choice	Tag	Main Module Defined Type	Subtype Used by Main Type
Analog Only	Configuration	AB:1756_OF8H:C:0	AB:1756_OF8H_ChConfig_Struct:C:0
	Input	AB:1756_OF8H_Analog:I:0	None
	Output	AB:1756_OF8H:O:0	None
Analog and HART PV	Configuration	AB:1756_OF8H:C:0	AB:1756_OF8H_ChConfig_Struct:C:0
	Input	AB:1756_OF8H_HARTPV:I:1	AB:1756_OF8H_HARTData:I:1 AB:1756_OF8H_HARTStatus_Struct:I:1
	Output	AB:1756_OF8H:O:0	None
Analog and HART by Channel	Configuration	AB:1756_OF8H:C:0	AB:1756_OF8H_ChConfig_Struct:C:0
	Input	AB:1756_OF8H_AnalogHARTbyChannel:I:0	AB:1756_OF8H_HARTDataAll_Struct:I:0 AB:1756_OF8H_HARTStatusAll_Struct:I:0
	Output	AB:1756_OF8H:O:0	None

Configuration

[Table 58](#) describes the configuration tags available in the 1756-OF8H module.

Table 58 - 1756-OF8H Configuration Tags (AB:1756_OF8H:C:0)

Member Name	Type	Style	Description
ProgToFaultEN	BOOL	Decimal	
ChxConfig (Ch 0...Ch7)	AB:1756_OF8H_ChConfig_Struct:C:0		
RampToFault	BOOL	Decimal	ConfigBits:9.
RampToProg	BOOL	Decimal	ConfigBits:8.
RampToRun	BOOL	Decimal	ConfigBits:7.
ProgMode	BOOL	Decimal	ConfigBits:6.
FaultMode	BOOL	Decimal	ConfigBits:5.
LimitAlarmLatch	BOOL	Decimal	ConfigBits:4.
RampAlarmLatch	BOOL	Decimal	ConfigBits:3.
AlarmDisable	BOOL	Decimal	ConfigBits:2.
HoldForInit	BOOL	Decimal	ConfigBits:1.
HARTEn	BOOL	Decimal	ConfigBits:0, HART enabled.
RangeType	INT	Decimal	0 = 0...20 mA. 1 = 4...20 mA.
MaxRampRate	REAL	Float	
FaultValue	REAL	Float	
ProgValue	REAL	Float	
LowSignal	REAL	Float	Lower current value for scaling to engineering units. Default is 4 mA. Must be less than HighSignal and more than minimum input range. See Scaling to Engineering Units on page 153 for more information.
HighSignal	REAL	Float	Upper current value for scaling to engineering units. Default is 10 mA. Must be more than LowSignal and less than maximum input range. See Scaling to Engineering Units on page 153 for more information.

Table 58 - 1756-OF8H Configuration Tags (AB:1756_OF8H:C:0)

Member Name	Type	Style	Description
LowEngineering	REAL	Float	Measured quantity in engineering units that results in a signal level equal to LowSignal. See Scaling to Engineering Units on page 153 for more information.
HighEngineering	REAL	Float	Measured quantity in engineering units that results in a signal level equal to HighSignal. See Scaling to Engineering Units on page 153 for more information.
LowLimit	REAL	Float	Output signal is clamped at this value in engineering units even if Ch0Data is lower than this.
HighLimit	REAL	Float	Output signal is clamped at this value in engineering units if Ch0Data is larger than this.
CalBias	REAL	Float	Sensor offset in engineering units added to the measured signal before reporting Ch0.Data.
PassthroughHandleTimeout	INT	Decimal	Seconds to keep a reply to a HART pass-through service request before discarding. 15 seconds recommended.
PassthroughFreq_14	BOOL	Decimal	Selects the policy for sending HART pass-through messages.
PassthroughFreq_15	BOOL	Decimal	See Pass-through Setting, Ratio, and Priority (Output Modules) on page 161 .

Analog Only

[Table 59](#) describes the input tags available in the Analog Only data format.

Table 59 - 1756-OF8H Input Tags - Analog Only (AB:1756_OF8H_Analog:I:0)

Member Name	Type	Style	Description
ChannelFaults	INT	Binary	ChannelFaults.x Indicates communication fault or fault condition from ChXStatus. (bits 9 . . . 15 unused).
ChxFault (Ch 0 . . . Ch7)	BOOL	Decimal	Indicates a channel fault on channel x.
LoopOutputFault	BOOL	Decimal	This is a hardware fault where the module has detected that the power supply to the isolated (analog) side of the board has failed (no power). It does not roll into any other bits. The OK status indicator is set to solid red.
HARTFaults	SINT	Binary	
ChxHARTFault	BOOL	Decimal	HARTFault.x Indicates a problem with HART data from the field device on Channel x. Examples are HART not enabled, HART device not connected, HART communication failure due to noise. These field device status conditions also cause this to be set: Device Malfunction, PV Out of Limits, Loop Current Saturated, and Loop Current Fixed.
ModuleFaults	SINT	Binary	
CalFault	BOOL	Decimal	(ModuleFaults.1) 1756-OF8H module calibration failed.
Calibrating	BOOL	Decimal	(ModuleStatus.2) Calibration in progress.
AnalogGroupFault	BOOL	Decimal	(ModuleFaults.7) Indicates that a fault has occurred on any channel (any of ChannelFaults).
ChxStatus (Ch 0 . . . Ch7)	SINT	Binary	Indicates various alarms on the analog signal. Also sets ChxFault for Overrange, Underrange, and CalFault.
ChxHLimitAlarm	BOOL	Decimal	(ChxStatus.0) The analog output signal is being limited by the ChxConfig.HighLimit value. If ChxConfig.LimitAlarmLatch is 1, alarm is retained until explicitly reset.
ChxLLimitAlarm	BOOL	Decimal	(ChxStatus.1) The analog output signal is being limited by the ChxConfig.LowLimit value. If ChxConfig.LimitAlarmLatch is 1, alarm is retained until explicitly reset.
ChxRampAlarm	BOOL	Decimal	(ChxStatus.2) Rate of change in ChxData exceeds ChxConfig.MaxRampRate. The change in ChxData divided by the RPI period determines the rate of change. Thus if a step change in Chx cannot be reached via the configured MaxRampRate within one RPI, then ChxRampAlarm is set to 1. If ChxConfig.RampAlarmLatch is 1, then ChxRampAlarm remains set until explicitly reset using CIP message even if the condition returns to normal. The CIP message can be sent via MSG instruction in the Logix controller or from the Module Properties Limit dialog box in the Logix Designer application.
ChxInHold	BOOL	Decimal	(ChxStatus.3) Channel holding its last output value, waiting for controller to match the value, indicating that bumpless initialization of the control loop is complete.
ChxCalFault	BOOL	Decimal	(ChxStatus.4) Fault during calibration of channel 0.
ChxNotANumber	BOOL	Decimal	(ChxStatus.5) ChxData is not a valid floating point number.

Table 59 - 1756-OF8H Input Tags - Analog Only (AB:1756_OF8H_Analog:I:0)

Member Name	Type	Style	Description
ChxOpenWire	BOOL	Decimal	(ChxStatus.7) Only valid in current mode (example 4...20 mA). 1 indicates that no current is flowing, probably due to open circuit.
ChxData (Ch 0...Ch7)	REAL	Float	Analog value actually output in engineering units. This can be different than output tag ChxData if the value exceeds the LowLimit or HighLimit, has a MaxRampRate applied, is being Held for initialization, or controller in Fault or Program mode.
CSTimestamp	DINT[2]	Decimal	64-bit coordinated system time timestamp in microseconds of the last output update. Timebase synchronized with other modules in the rack.
RollingTimestamp	INT	Decimal	16-bit timestamp in milliseconds. Timebase local to the 1756-OF8H module.

Analog and HART PV

[Table 60](#) describes the input tags available in the Analog and HART PV data format.

Table 60 - 1756-OF8H Input Tags - Analog Only (AB:1756_OF8H_HARTPV:I:1)

Member Name	Type	Style	Description
Channel Faults	INT	Binary	(bits 9...15 unused)
ChxFault	BOOL	Decimal	ChannelFaults.x, Indicates communication fault or fault condition from ChxStatus.
LoopOutputFault	BOOL	Decimal	ChannelFaults.8, This is a hardware fault where the module has detected that the power supply to the isolated(analog) side of the board has failed(no power). It does not roll into any other bits. The OK status indicator is set to solid red.
HARTFaults	SINT	Binary	
ChxHARTFault	BOOL	Decimal	HARTFault.x Indicates a problem with HART data from the field device on Channel x. Examples are HART not enabled, HART device not connected, HART communication failure due to noise. These field device status conditions also cause this to be set: Device Malfunction, PV Out of Limits, Loop Current Saturated, and Loop Current Fixed.
ModuleFaults	SINT	Binary	
CalFault	BOOL	Decimal	ModuleFaults.1, 1756-OF8H module calibration failed.
Calibrating	BOOL	Decimal	ModuleFaults.2, Calibration in progress.
UpdatedStatusReady	BOOL	Decimal	ModuleFaults.3, Module has collected updated Additional Device Status from HART command 48. This status can be retrieved by using the Read Additional Status service, 16#4C. For more information about this service, see Read Additional Status (Service Code = 16#4C) on page 181 .
AnalogGroupFault	BOOL	Decimal	ModuleFaults.7, Indicates a fault has occurred on any channel (any of ChannelFaults).
ChxStatus (Ch 0...Ch7)	SINT	Binary	Indicates various alarms on the analog signal. Also sets ChxFault for Overrange, Underrange, and CalFault.
ChxHLimitAlarm	BOOL	Decimal	ChxStatus:0 The analog output signal is being limited by the ChxConfig.HighLimit value. If ChxConfig.LimitAlarmLatch is 1, alarm is retained until explicitly reset.
ChxLLimitAlarm	BOOL	Decimal	ChxStatus:1 The analog output signal is being limited by the ChxConfig.LowLimit value. If ChxConfig.LimitAlarmLatch is 1, alarm is retained until explicitly reset.
ChxRampAlarm	BOOL	Decimal	ChxStatus:2 Rate of change in ChxData exceeds ChxConfig.MaxRampRate. The change in ChxData divided by the RPI period determines the rate of change. Thus if a step change in Chx cannot be reached via the configured MaxRampRate within one RPI, then ChxRampAlarm is set to 1. If ChxConfig.RampAlarmLatch is 1, then ChxRampAlarm remains set until explicitly reset using CIP message even if the condition returns to normal. The CIP message can be sent via MSG instruction in the Logix controller or from the Studio 5000® Module Properties Limit dialog box.
ChxInHold	BOOL	Decimal	ChxStatus:3 Channel holding its last output value, waiting for controller to match the value, indicating that bumpless initialization of the control loop is complete.
ChxCalfault	BOOL	Decimal	ChxStatus:4 Fault during calibration of channel x.
ChxNotANumber	BOOL	Decimal	ChxStatus:5 ChxData is not a valid floating point number.

Table 60 - 1756-OF8H Input Tags - Analog Only (AB:1756_OF8H_HARTPV:I:1)

Member Name	Type	Style	Description
ChxOpenWire	BOOL	Decimal	ChxStatus:7 Only valid in current mode (example 4...20 mA). 1 indicates that no current is flowing, probably due to open circuit.
ChxData	REAL	Float	Analog value actually output in engineering units. This can be different than Output Tag ChxData if the value exceeds the LowLimit or HighLimit, has a MaxRampRate applied, is being Held for initialization, or controller in Fault or Program mode.
CSTimestamp	DINT[2]	Decimal	64-bit coordinated system time timestamp in microseconds of the last output update. Timebase synchronized with other modules in the rack.
RollingTimestamp	INT	Decimal	16-bit timestamp in milliseconds. Timebase local to the 1756-OF8H module.
HART	AB:1756_OF8H_HARTData:I:1, Contains HART field device health and dynamic process variables This applies to AB:1756_OF8H_HARTPV:I:1 only; for details on what appears in the variables, see the Module-defined Data Type: AB:1756_OF8H_HARTData:I:1 table		
ChxDeviceStatus (Ch0...Ch7)	AB:1756_OF8H_HARTStatus_Struct:I:1, Channel 0 HART Device status info.		
Init	BOOL	Decimal	Searching for or Initializing HART device. If this value is 0 and Fail is 1, then HART is not enabled on this channel. If both are 1, then the 1756-OF8H module is sending out HART messages attempting to establish communication with a HART device.
Fail	BOOL	Decimal	HART communication failure or device not found or HART not enabled. If this bit is 1, none of the other data in the HART part of the input tag is valid. (HART.PVStatus is also set to 0 to indicate this).
MsgReady	BOOL	Decimal	Pass-through message reply is ready for query service.
CurrentFault	BOOL	Decimal	Analog current measurement does not match the current the field device reported over HART network.
ConfigurationChanged	BOOL	Decimal	The field device configuration has changed and new field device configuration information can be obtained from the 1756-OF8H module via CIP MSG GetDeviceInfo, which clears this bit.
ResponseCode	SINT	Binary	HART communication status byte or Response code from a recent HART reply. See Response Code and Field Device Status on page 229 for more information.
FieldDeviceStatus	SINT	Binary	HART device status byte from a recent HART reply. Indicates the health of the HART field device. See Field Device Status Bit Mask Definitions on page 230 for more information.
PVOutOfLimits	BOOL	Decimal	The primary variable is beyond its operating limit.
VariableOutOfLimits	BOOL	Decimal	A device variable that is not mapped to the PV is beyond its operating limits.
CurrentSaturated	BOOL	Decimal	The loop current has reached its upper or lower endpoint limit and cannot increase or decrease any further.
CurrentFixed	BOOL	Decimal	The loop current is being held at a fixed value and is not responding to process variations.
MoreStatus	BOOL	Decimal	More status information is available via command 48, 'Read Additional Status' information.
ColdStart	BOOL	Decimal	A power failure or device reset occurred.
Changed	BOOL	Decimal	An operation was performed that changed the configuration of the device.
Malfunction	BOOL	Decimal	The device detected a serious error or failure that compromises device operation.
ExtDeviceStatus	SINT	Binary	Extended device status (from HART cmd9).
Maintenance Required	BOOL	Decimal	Maintenance is needed.
DeviceVariableAlert	BOOL	Decimal	Device reports a problem with some measurement.
PowerLow	BOOL	Decimal	Low power.
ChxPV	REAL		Channel x HART PV value.
ChxSV	REAL		Channel x HART SV value.
ChxTV	REAL		Channel x HART TV value.
ChxFV	REAL		Channel x HART FV value.
ChxPVStatus	SINT		Channel x HART PV status, see HART PV, SV, TV, and FV Status on page 236 for more information.
ChxSVStatus	SINT		Channel x HART SV status, see HART PV, SV, TV, and FV Status on page 236 for more information.
ChxTVStatus	SINT		Channel x HART TV status, see HART PV, SV, TV, and FV Status on page 236 for more information.
ChxFVStatus	SINT		Channel x HART FV status, see HART PV, SV, TV, and FV Status on page 236 for more information.

Analog and HART by Channel

Table 61 - 1756-OF8H Input Tags - Analog and HART by Channel (AB:1756-OF8H_AnalogHARTbyChannel:I:0)

Member Name	Type	Style	Description
ChannelFaults	INT	Binary	(bits 9 . . . 15 unused).
ChxFault (Ch0 . . . Ch7)	BOOL		ChannelFaults.0 . . . ChannelFaults.7
LoopOutputFault	BOOL	Decimal	(ChannelFaults.8) This is a hardware fault where the module has detected that the power supply to the isolated(analog) side of the board has failed(no power). It does not roll into any other bits. The OK status indicator is set to solid red.
ModuleFaults	SINT	Binary	
CalFault	BOOL	Decimal	(ModuleFaults.1) 1756-OF8H module calibration failed.
Calibrating	BOOL	Decimal	(ModuleFaults.2) Calibration in progress.
UpdatedStatusReady	BOOL	Decimal	(ModuleFaults.3) Module has collected updated Additional Device Status from HART command 48. This status can be retrieved by using the Read Additional Status service, 16#4C. For more information about this service, see Read Additional Status (Service Code = 16#4C) on page 181 .
AnalogGroupFault	BOOL	Decimal	(ModuleFaults.7) Indicates that a fault has occurred on any channel (any of ChannelFaults).
Chx (Ch0 . . . Ch7)	AB:1756_OF8H_HARTDataAll_Struct:I:0, Channel 0 analog and HART data.		
Data	REAL	Float	Analog value in engineering units.
DeviceStatus	AB:1756_OF8H_HARTStatusAll_Struct:I:0, Channel 0 HART Device status info.		
HARTInit	BOOL	Decimal	Searching for or Initializing HART device. If this value is 0 and Fail is 1, then HART is not enabled on this channel. If both are 1, then the 1756-OF8H module is sending out HART messages to attempt to establish communication with a HART device.
HARTCommFail	BOOL	Decimal	HART communication failure or device not found or HART not enabled. If this bit is 1, none of the other data in the HART part of the input tag is valid. (HART.PVStatus is also set to 0 to indicate this.)
MsgReady	BOOL	Decimal	Pass-through message reply is ready for query service.
CurrentFault	BOOL	Decimal	Analog current measurement does not match the current the field device reported over the HART network.
ConfigurationChanged	BOOL	Decimal	The field device configuration has changed and new field device configuration information can be obtained from the 1756-OF8H module via CIP MSG GetDeviceInfo, which clears this bit.
BrokenWire	BOOL	Decimal	Indicates that current is not flowing through the module as expected. Broken wiring, RTB removal, or a powered-off field device can cause this.
HARTFault	BOOL	Decimal	Indicates a problem with HART data from the field device on Channel x. Examples are HART not enabled, HART device not connected, HART communication failure due to noise. These field device status conditions also cause this to be set: Device Malfunction, PV Out of Limits, Loop Current Saturated, and Loop Current Fixed.
ResponseCode	SINT	Binary	HART communication status byte or Response code from a recent HART reply. See Response Code and Field Device Status on page 229 for more information.
FieldDeviceStatus	SINT	Binary	HART device status byte from a recent HART reply. Indicates the health of the HART field device. See Field Device Status Bit Mask Definitions on page 230 for more information.
PVOutOfLimits	BOOL	Decimal	The primary variable is beyond its operating limit.
VariableOutOfLimits	BOOL	Decimal	A device variable that is not mapped to the PV is beyond its operating limits.
CurrentSaturated	BOOL	Decimal	The loop current has reached its upper or lower endpoint limit and cannot increase or decrease any further.
CurrentFixed	BOOL	Decimal	The loop current is being held at a fixed value and is not responding to process variations.
MoreStatus	BOOL	Decimal	More status information is available via command 48, 'Read Additional Status' information.
ColdStart	BOOL	Decimal	A power failure or device reset occurred.
Changed	BOOL	Decimal	An operation was performed that changed the configuration of the device.
Malfunction	BOOL	Decimal	The device detected a serious error or failure that compromises device operation.
ChStatus	SINT	Binary	Indicates various alarms on the analog signal. Also sets ChFault for Overrange, Underrange, and CalFault.
HLimitAlarm	BOOL	Decimal	Ch0.DeviceStatus.ChStatus:0 The analog output signal is being limited by the ChConfig.HighLimit value. If ChConfig.LimitAlarmLatch is 1, alarm is retained until explicitly reset.

Table 61 - 1756-OF8H Input Tags - Analog and HART by Channel (AB:1756-OF8H_AnalogHARTbyChannel:I:0)

Member Name	Type	Style	Description
LLimitAlarm	BOOL	Decimal	Ch0.DeviceStatus.ChStatus:1 The analog output signal is being limited by the ChConfig.LowLimit value. If ChConfig.LimitAlarmLatch is 1, alarm is retained until explicitly reset.
RampAlarm	BOOL	Decimal	ChStatus:2 Rate of change in Ch0.Data exceeds Ch0Config.MaxRampRate. The change in Ch0.Data divided by the RPI period determines the rate of change. Thus if a step change in Ch0.Data cannot be reached via the configured Ch0Config.MaxRampRate within one RPI, then Ch0.DeviceStatusRampAlarm is set to 1. If Ch0Config.RampAlarmLatch is 1, then Ch0.DeviceStatusRampAlarm remains set until explicitly reset by using CIP message even if the condition returns to normal. The CIP message can be sent via MSG instruction in the Logix controller or from the Logix Designer Module Properties Limit dialog box.
InHold	BOOL	Decimal	ChStatus:3 Channel holding its last output value, waiting for controller to match the value, indicating that bumpless initialization of the control loop is complete.
CalFault	BOOL	Decimal	ChStatus:4 Fault during calibration of channel 0.
NotANumber	BOOL	Decimal	ChStatus:5 Ch0.Data is not a valid floating point number.
OpenWire	BOOL	Decimal	ChStatus:7 Only valid in current mode (example 4...20 mA). 1 indicates that no current is flowing, probably due to open circuit.
ExtDeviceStatus	SINT	Binary	Extended device status (from HART cmd9)
Maintenance Required	BOOL	Decimal	Maintenance is needed.
DeviceVariableAlert	BOOL	Decimal	Device reports a problem with some measurement.
PowerLow	BOOL	Decimal	Low power.
PV	REAL	Float	Primary value. This is the same value as signaled on the analog channel and is the most important measurement that is made by this device.
SV	REAL	Float	Secondary value.
TV	REAL	Float	Third value.
FV	REAL	Float	Fourth value.
PVStatus	SINT	Hex	Primary status. 16#C0 = Connected. 16#00 = Not Connected.
SVStatus	SINT	Hex	Secondary status. 16#C0 = Connected. 16#00 = Not Connected.
TVStatus	SINT	Hex	Third status. 16#C0 = Connected. 16#00 = Not Connected.
FVStatus	SINT	Hex	Fourth status. 16#C0 = Connected. 16#00 = Not Connected.
CSTimestamp	DINT[2]	Hex	Coordinated system time.
RollingTimestamp	INT	Decimal	15-bit time from power on/reset in milliseconds.

Output

[Table 62](#) describes the output tags available in the 1756-OF8H module.

Table 62 - 1756-OF8H Output Tags (AB:1756_OF8H:0:0)

Member Name	Type	Style	Description
ChxData (Ch0...Ch7)	REAL	Float	Value in engineering units to output on the analog signal of Channel x.

1756-OF8IH HART Analog Output Module

Topic	Page
Module Features	123
Wire the Module	128
Output Circuit Diagram	128
1756-OF8IH Module Fault and Status Reporting	129
Module Calibration	133
Module-defined Data Types, 1756-OF8IH Module	134

Module Features

The 1756-OF8IH module has the following features:

- Eight individually controllable output channels with an individual HART modem per channel
- HART pass-through interface
- Two output ranges (0...20 mA, 4...20 mA)
- Auto-scanning of HART variables (PV, SV, TV, FV)
- Option to auto-configure a HART device with user-specified PV damping value, PV upper and lower range values, PV transfer function, and PV units code
- Write HART variables interface for some variables
- Output data scaling
- Time stamping
- Floating point output data
- Ramping (rate limiting)
- Choice of four data formats
 - Analog Only
 - Analog and HART PV
 - Analog and HART by Channel with Configure HART Device = Yes
 - Analog and HART by Channel with Configure HART Device = No
- User calibration via CIP messaging or output word
- 15-bit or 16-bit resolution
- Hold for initialization
- Open wire detection
- Clamp limit alarms
- Data echo

Data Formats

Data format determines which values are included in the Input tag of the module and the features that are available to your application. Select the data format on the General tab in the Studio 5000 Logix Designer® application. The following data formats are available for the 1756-OF8IH module.

Data Format	Description				
	Analog Signal Values	Analog Status	HART Secondary Process Variables and Device Health	HART and Analog Data for Each Channel Grouped Together in Tag	Configure HART Device
Analog Only	X	X			
Analog and HART PV	X	X	X		
Analog and HART by Channel, Configure HART Device = No	X	X	X	X	
Analog and HART by Channel, Configure HART Device = Yes	X	X	X	X	X

Choose Analog and HART PV if you prefer the members of your tag to be arranged similar to non-HART analog input modules. With this selection, the analog values for all channels grouped near the end of the tag. This arrangement makes it easy to view all eight analog values at once.

Choose Analog and HART by Channel if you prefer Status, Analog Value, and Device Status for each channel to be together in the tag. This arrangement makes it easier to view all data that is related to one field device.

Powerup State

On powerup, the outputs of the 1756-OF8IH module are set to their reset state (0 mA) until module diagnostics and configuration are complete. Outputs are then set at their configured program values (ChxConfig.ProgValue).

Fault Mode Output State

You can choose the output state to be used when the module enters fault mode:

- Hold Last State
- User-defined Value (you can choose either to ramp to a specified value or to switch immediately to that value)

Ramping (Rate Limiting)

Ramping limits the rate at which an analog output signal can change. This feature prevents fast transitions in the output from damaging the devices that an output module controls.

Table 63 - Ramping Types

Ramping Types	Description
Ramp-to-Run	When the module is in Run mode, it limits the rate at which the output changes from one commanded value to another.
Ramp-to-Program	When the controller goes into program mode, the present output value ramps to the configured Program Value. If the connection to the module is inhibited, the Program mode value and ramp rate are applied.
Ramp-to-Fault	When a communication fault occurs, the output signal ramps to the configured fault value.

The maximum rate of change in outputs is expressed in engineering units per second and called the **maximum ramp rate**.

For more information about ramp rate, see [Chapter 9, Configure Modules in the Logix Designer Application](#).

Hold for Initialization

Hold for Initialization causes outputs to hold present state until the value that the controller commands matches the value at the output terminal within 0.1% of full scale. This feature helps provide a bumpless transfer.

If Hold for Initialization is selected, outputs hold if any of these conditions occur:

- Initial connection is established after power-up.
- A new connection is established after a communication fault occurs.
- There is a transition from Program mode to Run mode.

The ChxInHold bit for a channel indicates that the channel is holding.

Open Wire Detection

This feature detects when current flow is not present at the channel. At least 0.1 mA of current must be flowing from the output for detection to occur.

When an open wire condition occurs at any channel, a status bit named ChxOpenWire is set for that channel.

Clamping (Limiting)

Clamping limits the output from the analog module to remain within a range that the controller configures, even when the controller commands an output outside that range. This safety feature sets a high clamp value and a low clamp value.

Once clamps are set for a channel, data from the controller that exceeds the clamp values sets a limit alarm. The output transitions to that limit but not beyond the configured clamp value. For example, suppose that an application sets the high clamp on a module for 18 mA and the low clamp for 4 mA. If a controller sends a value that corresponds to 19 mA to the module, the module only applies 18 mA via its screw terminals. The signal value that is applied is reflected in the Input Tag ChxData field.

Clamping limits are entered in engineering units.

Clamp and Limit Alarms

This function works directly with clamping. When a module receives a data value from the controller that exceeds clamping limits, it applies the clamping limit to the signal value and sends a status bit to the controller. This action notifies the controller that the commanded output data value exceeds the clamping limits.

For example, if a channel has a clamping limit of 18 mA but receives data to apply 19 mA, only 18 mA is applied via the screw terminals. The module sends a status bit to the controller to inform it that the 19 mA value exceeds the clamping limits of the channel.

Clamping alarms can be disabled or latched on a per channel basis. Clamping limits are entered in engineering units.

Data Echo

Data Echo automatically multicasts channel data values that match the analog value that is applied to the module screw terminals.

Fault and status data are also sent. If selected in the Input Data format, HART secondary process variables and device health are also sent.

An example is that I.ChxDData is the echo of O.ChxDData. They can be different due to Ramp, Clamp, or Hold for Initialization.

The echo value is the current level being attempted. If the wire is off or damaged, the actual current can be 0.

HART Device Auto-configuration

A HART device can be automatically configured with user-specified PV damping, PV range limits and units, and PV transfer function values. If enabled, configuration occurs when the device is connected or when the module detects that one of two configuration bits is set. There is a separate configuration bit for PV damping value, and another for PV upper and lower range values, PV transfer function, and PV range units.

This feature is available only with the Analog and HART by Channel data format with Configure HART Device = Yes.

Write HART Variables

The module supports setting a limited number of HART variables via special use of the pass-through interface. See [Chapter 10, Use a CIP MSG to get HART Data](#), for more information.

Wire the Module

Use [Figure 29](#) to wire the module. The 1756-OF8IH module has only current outputs, which use the terminal block pins labeled IOOUT# and RTN#.

For each output, HART communication is active only when it is enabled in the Logix Designer application.

Figure 29 - Wiring Diagram for the 1756-OF8IH Module

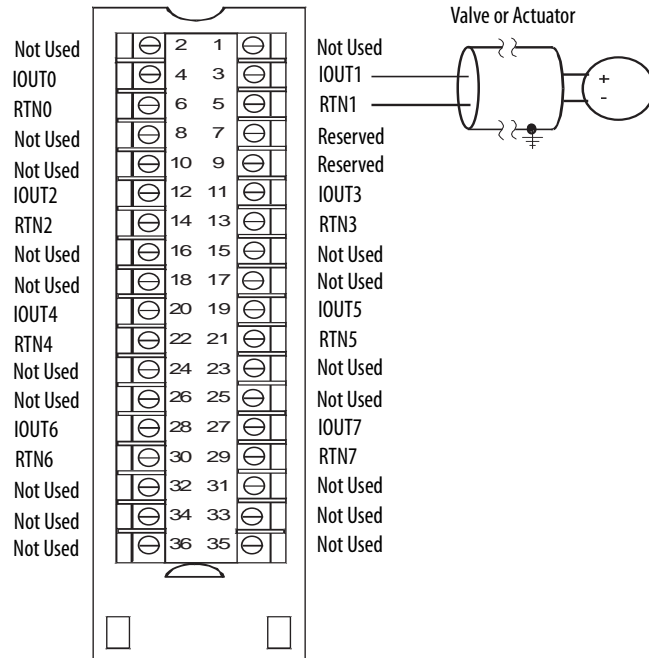

Output Circuit Diagram

This section shows the module output circuit diagram.

Figure 30 - 1756-OF8IH Output Circuit Diagram

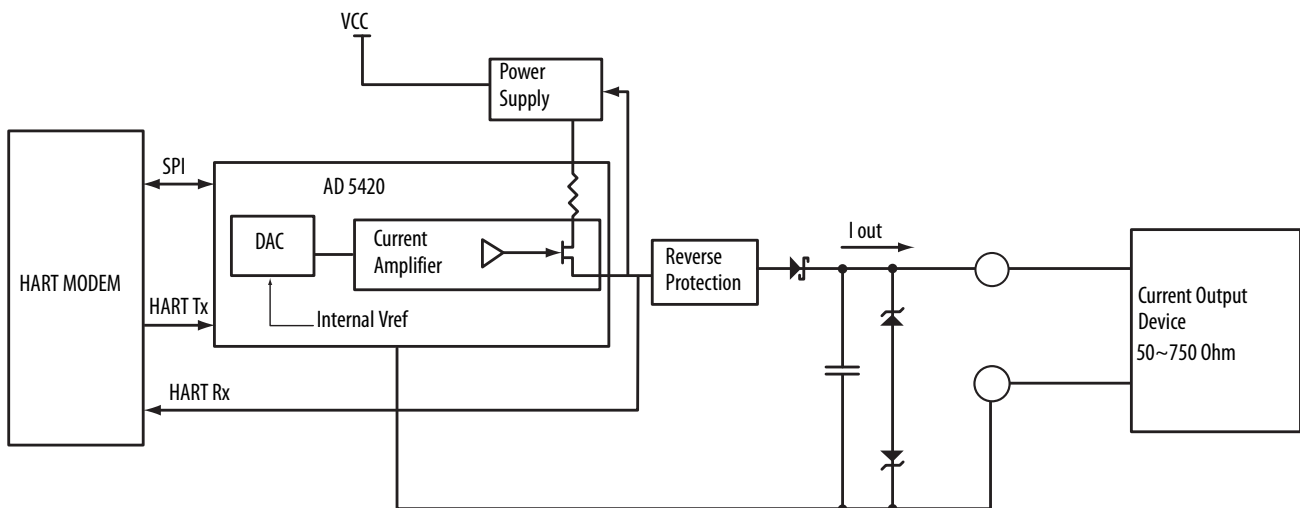

1756-OF8IH Module Fault and Status Reporting

The 1756-OF8IH modules multicast status and fault data to the controller with their channel data. The fault data is arranged to let you choose the level of granularity you desire for examining fault conditions.

Three levels of tags work together to provide increasing degree of detail as to the specific cause of faults on the module.

[Table 64](#) lists tags that you can examine in ladder logic to indicate when a fault occurred.

Table 64 - 1756-OF8IH Tags That Can Be Examined in Ladder Logic

Tag	Description	Tag Name Analog and HART PV	Tag Name Analog and HART by Channel
Module Fault Word	The bits in this word are set when a fault of the corresponding type has occurred on any channel.	ModuleFaults	ModuleFaults
Channel Fault Word	These bits report faults that occur on the corresponding channel.	ChannelFaults ChxFault	ChannelFaults ChxFault
Channel Status Tags	These words, one per channel, indicate individual channel limit, hold, open wire, ramp status, and calibration faults.	ChxStatus	Chx.DeviceStatus Chx.DeviceStatus.AlarmStatus
HART Faults	The bits in this word show HART communication status for each channel.	HARTFaults, ChxHARTFault	Chx.DeviceStatus.HARTFault
HART Device Status	This data provides information about the HART field device.	HART.ChxDevice Status	Chx.DeviceStatus.FieldDeviceStatus

1756-OF8IH Module Fault Reporting

Figure 31 offers an overview of the fault reporting process.

Figure 31 - 1756-OF8IH Module Fault Reporting

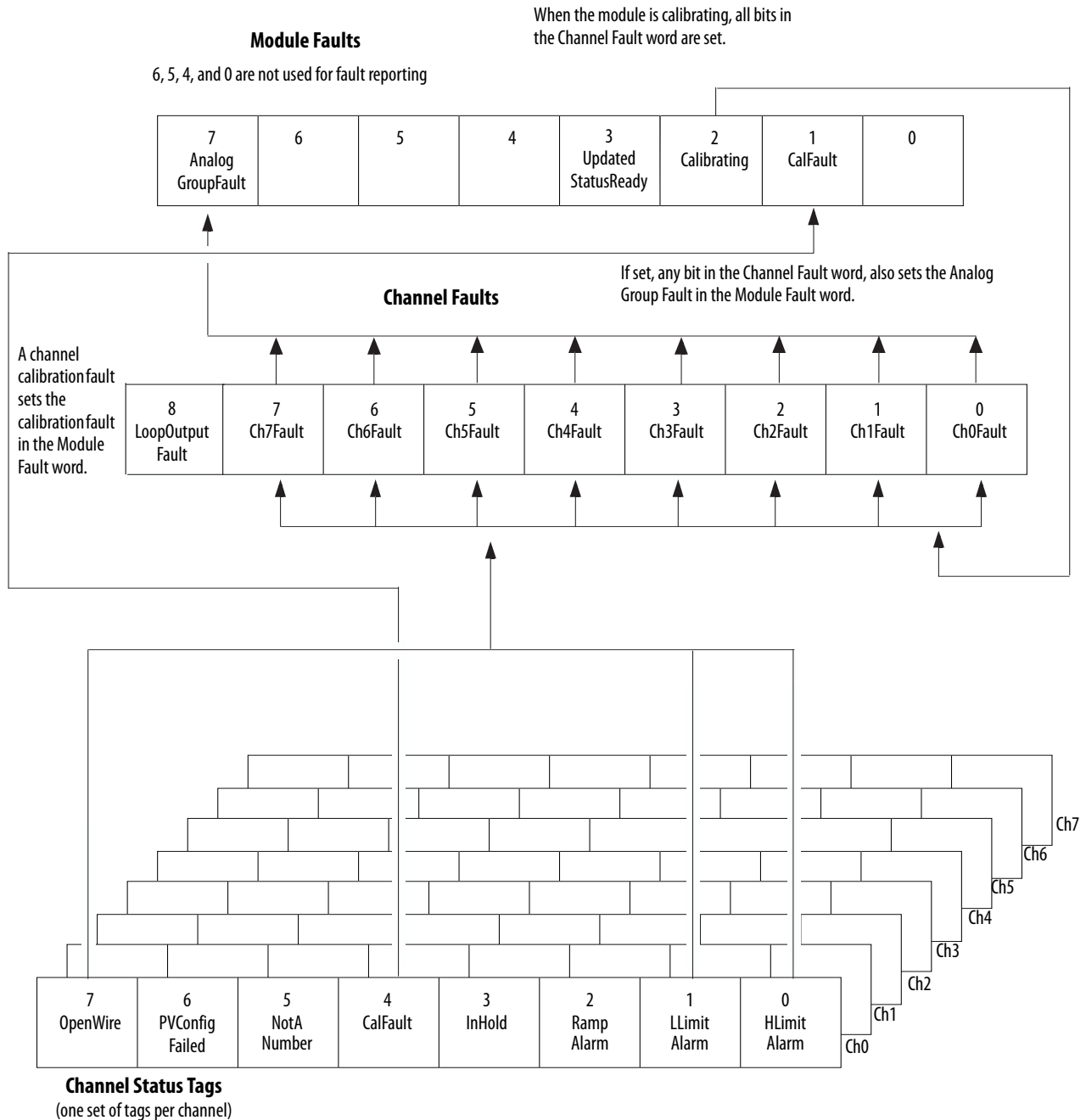

- Notes:**
- NotANumber, InHold, RampAlarm, and PVConfigFailed conditions do not set other bits; monitor them here.
 - Bits 0 and 1 not used if Configure HART Device = Yes
 - Bit 6 not used if Configure HART Device = No

Module Fault Word Bits

Bits in this word provide the highest level of fault detection. A nonzero condition in this word reveals that a fault exists on the module. You can examine further down to isolate the fault.

Table 65 - 1756-OF8IH Tags Found in the Module Fault Word

Tag	Description	Tag Name
Analog Group Fault	This bit is set when any bits in the Channel Fault word are set.	AnalogGroupFault
Calibrating	This bit is set when any channel is being calibrated. When this bit is set, all bits in the Channel Fault word are set.	Calibrating
Calibration Fault	This bit is set when any of the individual Channel Calibration Fault bits are set.	CalFault

Channel Fault Word Bits

During normal module operation, bits in the Channel Fault word are set if any of the respective channels has a High or Low Limit Alarm or an Open Wire condition (4...20 mA configurations only). When using the Channel Fault Word, the 1756-OF8IH module uses bits 0...7. Check this word for a nonzero condition as a quick way to check for these conditions on a channel.

Table 66 - 1756-OF8IH Conditions That Set All Channel Fault Word Bits

This Condition Sets All Channel Fault Word Bits	And Causes the Module to Display the Following in the Channel Fault Word Bits
A channel is being calibrated	16#00FF
A communication fault occurred between the module and its owner-controller	1#FFFF

Monitor the Channel Fault bit for a particular output in ladder logic for the following reasons:

- You enable output clamping, are checking for an open wire condition (4...20 mA configuration only)
- You must know if the output module is not communicating with the controller

Your logic can use the bit in Channel Faults, for example, Ch2Fault, to take failure recovery action, such as signaling CVFault on a PIDE function block.

Channel Status Tags

Any of the channel status words (eight words for 1756-OF8IH modules, one for each channel) display a nonzero condition if that particular channel has faulted. Some of these bits set bits in other Fault words.

When the High or Low Limit Alarm bits (ChxHLimitAlarm or ChxLLimitAlarm) in any of the words are set, the appropriate bit is set in the Channel Fault word.

When the Calibration Fault bit (CalFault) is set in any of the words, the Calibration Fault bit (bit 11) is set in the Module Fault word. [Table 67](#) lists the conditions that set each of the word bits.

Table 67 - 1756-OF8IH Conditions That Set Channel Status Word Bits⁽¹⁾, Configure HART Device = No

Tag (Status Words)	Bit	Event That Sets This Tag
ChxOpenWire Chx.DeviceStatus.OpenWire	7	This bit is set only if the circuit becomes open due to a wire falling off or being cut when the output being driven is above 0.1 mA. The bit remains set until correct wiring is restored.
ChxNotaNumber ⁽²⁾ Chx.DeviceStatus.NotANumber	5	This bit is set when the output value that is received from the controller is NotANumber (the IEEE NaN value). The output channel holds its last state.
ChxCalFault Chx.DeviceStatus.CalFault	4	This bit is set when an error occurred when calibrating. This bit also sets the appropriate bit in the Channel Fault word.
ChxInHold ⁽²⁾ Chx.DeviceStatus.InHold	3	This bit is set when the output channel is holding. The bit resets when the requested Run mode output value is within 0.1% of full-scale of the current echo value.
ChxRampAlarm ⁽²⁾ Chx.DeviceStatus.RampAlarm	2	This bit is set when the requested rate of change for an output channel would exceed the configured maximum ramp rate requested parameter. It remains set until the output reaches its target value and ramping stops. If the bit is latched, it remains set until it is unlatched.
ChxLLimitAlarm Chx.DeviceStatus.LLimitAlarm	1	This bit is set when the requested output value is beneath the configured low limit value. It remains set until the requested output is above the low limit. If the bit is latched, it remains set until it is unlatched.
ChxHLimitAlarm Chx.DeviceStatus.HLimitAlarm	0	This bit is set when the requested output value is above the configured high limit value. It remains set until the requested output is below the high limit. If the bit is latched, it remains set until it is unlatched.

(1) Bit 6 is not used.

(2) This bit does not set other bits at any higher level.

Table 68 - 1756-OF8IH Conditions That Set Channel Status Word Bits⁽¹⁾, Configure HART Device = Yes

Tag (Status Words)	Bit	Event That Sets This Tag
ChxOpenWire Chx.DeviceStatus.OpenWire	7	This bit is set only if the circuit becomes open due to a wire falling off or being cut when the output being driven is above 0.1 mA. The bit remains set until correct wiring is restored.
ChxPVConfigFailed Chx.DeviceStatus.PVConfigFailed	6	PV auto-configuration failed.
ChxNotaNumber ⁽²⁾ Chx.DeviceStatus.NotANumber	5	This bit is set when the output value that is received from the controller is NotANumber (the IEEE NaN value). The output channel holds its last state.
ChxCalFault Chx.DeviceStatus.CalFault	4	This bit is set when an error occurred when calibrating. This bit also sets the appropriate bit in the Channel Fault word.
ChxInHold ⁽²⁾ Chx.DeviceStatus.InHold	3	This bit is set when the output channel is holding. The bit resets when the requested Run mode output value is within 0.1% of full-scale of the current echo value.
ChxRampAlarm ⁽²⁾ Chx.DeviceStatus.RampAlarm	2	This bit is set when the requested rate of change for an output channel would exceed the configured maximum ramp rate requested parameter. It remains set until the output reaches its target value and ramping stops. If the bit is latched, it remains set until it is unlatched.

(1) Bits 0 and 1 are not used.

(2) This bit does not set other bits at any higher level.

Module Calibration

There are two ways to initiate calibration of the 1756-OF8IH module:

- Logix Designer application Calibration tab
- Module Output Word

Module Calibration Via Logix Designer Application

The Calibration tab in the Logix Designer application provides a button to initiate module calibration and a display of the results. Refer to [Calibration Tab on page 170](#) for more information.

Module Calibration Via Output Word

The 1756-OF8IH module allows you to perform calibration by setting and clearing bits in the module output word. This method of calibration is available only when Configure HART Device = Yes. The module must be connected to a controller and the controller must be in run mode.

See [Table 77 on page 143](#) for output bit descriptions.

To perform a module calibration via the output word, set and clear bits in sequence to perform the calibration tasks. The table shows the tags that are involved in calibration.

Step	Calibration Word Bits	Description
Initiate calibration	Ch[x].Calibrate	Set this bit to initiate calibration, and keep it set until the calibration sequence is complete. If this bit clears before the calibration is complete, the calibration is aborted.
Output low calibration reference	Ch[x].CalOutputLowRef	Sets the output to 4 mA.
Pass measured low calibration output to ChxData	Ch[x].CalLowRefPassed	Captures the low calibration value.
Output high calibration reference	Ch[x].CalOutputHighRef	Sets the output to 20 mA.
Pass measured high calibration output to Chx Data	Ch[x].CalHighRefPassed	Captures the high calibration value.
Finish calibration	Ch[x].CalFinished	Initiates calculation of the calibration for that channel. If all other channels have been calculated and complete, the calibration date is written and calibration terminates.
Abort calibration	Ch[x].Calibrate Ch[x].CalOutputLowRef Ch[x].CalOutputHighRef	If necessary, this bit combination aborts calibration.
Set the calibration date	CalibrationDate	The date to be recorded with a successful calibration, typically the current date.

Module-defined Data Types, 1756-OF8IH Module

Table 69...Table 77 describe module-defined data types for the 1756-OF8IH module and include information for configuration, input, and output tags. Available tags depend on the selected input data format, as shown in Table 69.

Table 69 - 1756-OF8IH Input Data Choice and Tags

Input Data Choice	Tag	Main Module Defined Type	Subtype Used by Main Type
Analog Only	Configuration	AB:1756_OF8IH:C:0	AB:1756_OF8IH_ChConfig_Struct:C:0
	Input	AB:1756_OF8IH_Analog:I:0	None
	Output	AB:1756_OF8IH:O:0	None
Analog and HART PV	Configuration	AB:1756_OF8IH:C:0	AB:1756_OF8IH_ChConfig_Struct:C:0
	Input	AB:1756_OF8IH_HARTPV:I:1	None
	Output	AB:1756_OF8IH:O:0	None
Analog and HART by Channel Configure HART Device = No	Configuration	AB:1756_OF8IH:C:0	AB:1756_OF8IH_ChConfig_Struct:C:0
	Input	AB:1756_OF8IH_AnalogHARTbyChannel:I:0	AB:1756_OF8IH_HARTDataAll_Struct:I:0
	Output	AB:1756_OF8IH:O:0	None
Analog and HART by Channel Configure HART Device = Yes	Configuration	AB:1756_OF8IH_HART_CMD:C:0	AB:1756_OF8IH_HART_ChConfig_Struct:C:0
	Input	AB:1756_OF8IH_AnalogHARTbyChannel_1:I:0	AB:1756_OF8IH_HARTDataAll_1_Struct:I:0
	Output	AB:1756_OF8IH:O:0	AB:1756_OF8IH_ChStruct:O:0

1756-OF8IH Configuration, Configure HART Device = No

Table 70 describes configuration tags available in the 1756-OF8IH module when Configure HART Device is set to No.

Table 70 - 1756-OF8IH Configuration Tags, Configure HART Device = No (AB:1756_OF8IH:O:0)

Member Name	Type	Style	Description
ProgToFaultEn	BOOL	Decimal	0 – Disabled. 1 – Enable programmed fault states. Determines how outputs can behave if a communication fault occurs while the module is in program mode. When set, the bit causes outputs to transition to their programmed fault state. If not set, outputs remain in their configured program state despite a communications fault occurring.
ChxConfig (Ch 0...Ch7)	AB:1756_OF8IH_ChConfig_Struct:C:0		
RampToFault	BOOL	Decimal	Enables ramping of the output value to the value specified by FaultValue. MaxRampRate defines the transition ramp rate. HoldOnFault must be set to 1 if RampToFault is set to 1.
RampToProg	BOOL	Decimal	Selects the ramping behavior when the system transitions from Run to Idle/Program mode. Enable ramping of the output to the fvalue specified by IdleProgValue. MaxRampRate defines the ramp rate. HoldOnIdle must be set to 1 if RampToProg is set to 1 and MaxRampRate must be > 0.
RampToRun	BOOL	Decimal	Enables ramping of the output value during Run mode between the current output level and a newly requested output. MaxRampRate defines the transition ramp rate and must be > 0.
ProgMode	BOOL	Decimal	
FaultMode	BOOL	Decimal	
LimitAlarmLatch	BOOL	Decimal	Enables latching for the clamp limit alarms. Latching causes the limit alarms to remain set until an unlatch service is explicitly sent to the channel or alarm. (1 = enable, 0 = disable.)

Table 70 - 1756-OF8IH Configuration Tags, Configure HART Device = No (AB:1756_OF8IH:0:0)

Member Name	Type	Style	Description
RampAlarmLatch	BOOL	Decimal	Enables latching for the rate alarm. Latching causes the rate alarm to remain set until an unlatch service is explicitly sent to the channel or alarm. (1 = enable, 0 = disable.)
AlarmDisable	BOOL	Decimal	Disables all alarms for the channel: HLimitAlarm, LLimitAlarm, RampAlarm. (1 = disable alarms, 0 = do not disable alarms.)
HoldForInit	BOOL	Decimal	Configures the channel to hold, or not change, until initialized with a value within 0.1% of full scale or its current value when one of the following conditions occurs: <ul style="list-style-type: none"> Module initial connection powerup. Module transition from Program mode to Run mode. Module re-establishes communication after a fault.
HARTEn	BOOL	Decimal	Enables HART communication.
RangeType	INT	Decimal	1 = 0...20 mA. 2 = 4...20 mA. (The 1756-OF8IH does not support voltage outputs.)
MaxRampRate	REAL	Float	Maximum allowable transition rate in user-specified scaling units per second. The value: <ul style="list-style-type: none"> Must be greater than zero if RampToFault, RampToProg, or RampToRun is set. Must equal zero if RampToFault, RampToProg, and RampToRun are all not set. Cannot be greater than 2 x full scale maximum. When HART is enabled, the channel enforces a fixed maximum ramp rate regardless of RampToFault, RampToProg, and RampToRun settings; this is done to help avoid HART transmission noise.
FaultValue	REAL	Float	Communication fault output value.
ProgValue	REAL	Float	Program mode output value.
LowSignal	REAL	Float	Lower current value for scaling to engineering units. Default is 4 mA. Must be less than HighSignal and more than minimum input range. See Scaling to Engineering Units on page 153 for more information.
HighSignal	REAL	Float	Upper current value for scaling to engineering units. Default is 10 mA. Must be more than LowSignal and less than maximum input range. See Scaling to Engineering Units on page 153 for more information.
LowEngineering	REAL	Float	Measured quantity in engineering units that results in a signal level equal to LowSignal. See Scaling to Engineering Units on page 153 for more information.
HighEngineering	REAL	Float	Measured quantity in engineering units that results in a signal level equal to HighSignal. See Scaling to Engineering Units on page 153 for more information.
LowLimit	REAL	Float	Output signal is clamped at this value in engineering units even if Ch0Data is lower than this.
HighLimit	REAL	Float	Output signal is clamped at this value in engineering units if Ch0Data is larger than this.
CalBias	REAL	Float	Sensor offset in engineering units added to the measured signal before reporting Ch0.Data.
PassthroughHandleTimeout	INT	Decimal	Response hold time in seconds (0...255).
PassthroughFreq_14	BOOL	Decimal	Selects the policy for sending HART pass-through messages. See Pass-through Setting, Ratio, and Priority (Output Modules) on page 161 .
PassthroughFreq_15	BOOL	Decimal	

1756-OF8IH Configuration, Configure HART Device = Yes

[Table 71](#) describes configuration tags available in the 1756-OF8IH module when Configure HART Device is set to Yes.

Table 71 - 1756-OF8IH Configuration Tags, Configure HART Device = Yes (AB:1756_OF8IH_HART_CMD:C:0)

Member Name	Type	Style	Description
ProgToFaultEn	BOOL	Decimal	0 – Disabled. 1 – Enable programmed fault states. Determines how outputs can behave if a communication fault occurs while the module is in program mode. When set, the bit causes outputs to transition to their programmed fault state. If not set, outputs remain in their configured program state despite a communications fault occurring.
ChxConfig (Ch 0...Ch7)	AB:1756_OF8IH_ChConfig_Struct:C:0		
RampToFault	BOOL	Decimal	Enables ramping of the output value to the value specified by FaultValue. MaxRampRate defines the transition ramp rate. HoldOnFault must be set to 1 if RampToFault is set to 1.
RampToProg	BOOL	Decimal	Selects the ramping behavior when the system transitions from Run to Idle/Program mode. Enable ramping of the output to the value specified by IdleProgValue. MaxRampRate defines the ramp rate. HoldOnIdle must be set to 1 if RampToProg is set to 1 and MaxRampRate must be > 0.
RampToRun	BOOL	Decimal	Enables ramping of the output value during Run mode between the current output level and a newly requested output. MaxRampRate defines the transition ramp rate and must be > 0.
ProgMode	BOOL	Decimal	
FaultMode	BOOL	Decimal	
HoldForInit	BOOL	Decimal	Configures the channel to hold, or not change, until initialized with a value within 0.1% of full scale or its current value when one of the following conditions occurs: <ul style="list-style-type: none"> • Module initial connection powerup. • Module transition from Program mode to Run mode. • Module re-establishes communication after a fault.
HARTEn	BOOL	Decimal	Enables HART communication.
PVDampingConfigEn	BOOL	Decimal	
PVRangeConfigEn	BOOL	Decimal	
RangeType	INT	Decimal	1 = 0...20 mA. 2 = 4...20 mA. (The 1756-OF8IH does not support voltage outputs.)
MaxRampRate	REAL	Float	Maximum allowable transition rate in user-specified scaling units per second. The value must meet these conditions: <ul style="list-style-type: none"> • Must be greater than zero if RampToFault, RampToProg, or RampToRun is set. • Must equal zero if RampToFault, RampToProg, and RampToRun are all not set. • Cannot be greater than 2 x full scale maximum. When HART is enabled, the channel enforces a fixed maximum ramp rate regardless of RampToFault, RampToProg, and RampToRun settings; this is done to help avoid HART transmission noise.
FaultValue	REAL	Float	Communication fault output value.
ProgValue	REAL	Float	Program mode output value
LowEngineering	REAL	Float	Measured quantity in engineering units that results in a signal level equal to LowSignal. See Scaling to Engineering Units on page 153 for more information.
HighEngineering	REAL	Float	Measured quantity in engineering units that results in a signal level equal to HighSignal. See Scaling to Engineering Units on page 153 for more information.
PVDamping	REAL	Float	PV Damping value in seconds (See HART Command Tab - 1756-IF8IH, 1756-OF8IH on page 169).
PVLowerRange	REAL	Float	PV Range low value (See HART Command Tab - 1756-IF8IH, 1756-OF8IH on page 169).
PVUpperRange	REAL	Float	PV Range high value (See HART Command Tab - 1756-IF8IH, 1756-OF8IH on page 169).
PVUnits	SINT	Decimal	PV Units (See HART Command Tab - 1756-IF8IH, 1756-OF8IH on page 169).
PVTransferFunction	SINT	Decimal	PV transfer function (See HART Command Tab - 1756-IF8IH, 1756-OF8IH on page 169).

Table 71 - 1756-OF8IH Configuration Tags, Configure HART Device = Yes (AB:1756_OF8IH_HART_CMD:C:0)

Member Name	Type	Style	Description
CalBias	REAL	Float	Sensor offset in engineering units added to the measured signal before reporting Ch0.Data.
PassthroughHandleTimeout	INT	Decimal	Response hold time in seconds (0...255).
PassthroughFreq_14	BOOL	Decimal	Selects the policy for sending HART pass-through messages. See Pass-through Setting, Ratio, and Priority (Output Modules) on page 161 .
PassthroughFreq_15	BOOL	Decimal	

1756-OF8IH Input - Analog Only

[Table 72](#) describes the input tags available in the Analog Only data format for the 1756-OF8IH module.

Table 72 - 1756-OF8IH Input Tags - Analog Only Data Format (AB:1756_OF8IH_Analog:I:0)

Member Name	Type	Style	Description
ChannelFaults	INT	Binary	Channel level fault status bits.
ChxFault (Ch 0...Ch7)	BOOL	Decimal	(ChannelFaults.0...ChannelFaults.7) Indicates a fault on the corresponding channel.
LoopOutputFault	BOOL	Decimal	Loop output failure. Set when 24V DC backplane power is below 17.5V ($\pm 1.2V$).
HARTFaults	INT	Binary	HART fault status bits.
ChxHARTFault (Ch 0...Ch7)	BOOL	Decimal	(HARTFaults.0...HARTFaults.7) Indicates a HART fault on the corresponding channel.
ModuleFaults	INT	Binary	Module level fault status.
CalFault	BOOL	Decimal	A calibration fault has occurred on a channel.
Calibrating	BOOL	Decimal	Calibration is in progress.
AnalogGroupFault	BOOL	Decimal	Indicates that a channel fault has occurred.
ChxStatus (Ch 0...Ch7)	INT	Binary	Channel level status bits.
ChxHLimitAlarm (Ch 0...Ch7)	BOOL	Decimal	User value is equal to or greater than HighLimit configuration value. Automatically set to zero when AlarmDisable is set.
ChxLLimitAlarm (Ch 0...Ch7)	BOOL	Decimal	User value equal to or greater than LowLimit configuration value. Automatically set to zero when AlarmDisable is set.
ChxRampAlarm (Ch 0...Ch7)	BOOL	Decimal	Set when output is ramping to new user value. Cleared when ramping is complete. This bit is not set if MaxRampRate is zero. This bit is always zero when the AlarmDisable configuration bit is set.
ChxInHold (Ch 0...Ch7)	BOOL	Decimal	If HoldForInit bit is set, the module is waiting for the appropriate Output word.
ChxCalFault (Ch 0...Ch7)	BOOL	Decimal	Set when calibration is invalid for this channel.
ChxNotANumber (Ch 0...Ch7)	BOOL	Decimal	Set when Output word has all 8 bits set.
ChxOpenWire (Ch 0...Ch7)	BOOL	Decimal	Set when Output is commanded to at least 0.1 mA and the circuit is physically open. Open circuit indication can also exist if the load resistance exceeds specification.
ChxData (Ch 0...Ch7)	REAL	Float	Value of analog signal on Channel x after conversion to engineering units.
CSTimestamp	DINT (2)	Decimal	64-bit Coordinated System Time. Timestamp that is taken at the time the input data was sampled in terms of coordinated system time, which is a 64-bit value in microseconds coordinated across the modules in the 1756 backplane.
RollingTimestamp	INT	Decimal	15-bit time from power on/reset in milliseconds. This value is updated when the Output Table changes. If ramping is enabled the value continuously updates until the output value reaches the user value. If the module has entered a faulted state, updated continuously.

1756-OF8IH Input - Analog and HART PV

Table 73 describes the input tags available in the Analog and HART PV data format for the 1756-OF8IH module.

Table 73 - 1756-OF8IH Input Tags - Analog and HART PV Data Format (AB:1756_OF8IH_HARTPV:I:1)

Member Name	Type	Style	Description
ChannelFaults	INT	Binary	Channel level fault status bits.
ChxFault (Ch 0...Ch7)	BOOL	Decimal	A fault has occurred on the corresponding channel.
LoopOutputFault	BOOL	Decimal	Loop output failure. Set when 24V DC backplane power is below 17.5V ($\pm 1.2V$).
HARTFaults	INT	Binary	HART fault status bits.
ChxHARTFault (Ch 0...Ch7)	BOOL	Decimal	(HARTFaults.0...HARTFaults.7) Indicates a HART fault on the corresponding channel.
ModuleFaults	INT	Binary	Module level fault status.
CalFault	BOOL	Decimal	A calibration fault has occurred on a channel.
Calibrating	BOOL	Decimal	Calibration is in progress.
UpdatedStatusReady	BOOL	Decimal	Updated Cmd48 status data available.
AnalogGroupFault	BOOL	Decimal	Indicates that a channel fault has occurred.
ChxStatus (Ch0...Ch7)	INT	Binary	
ChxHLimitAlarm	BOOL	Decimal	User value is equal to or greater than HighLimit configuration value. Automatically set to zero when AlarmDisable is set.
ChxLLimitAlarm	BOOL	Decimal	User value equal to or greater than LowLimit configuration value. Automatically set to zero when AlarmDisable is set.
ChxRampAlarm	BOOL	Decimal	Set when output is ramping to new user value. Cleared when ramping is complete. This bit is not set if MaxRampRate is zero. This bit is always zero when the AlarmDisable configuration bit is set.
ChxInHold	BOOL	Decimal	If HoldForInit bit is set, the module is waiting for the appropriate Output word.
ChxCalFault	BOOL	Decimal	Set when calibration is invalid for this channel.
ChxNotANumber	BOOL	Decimal	Set when Output word has all 8 bits set.
ChxOpenWire	BOOL	Decimal	Set when Output is commanded to at least 0.1 mA and the circuit is physically open. Open circuit indication can also exist if the load resistance exceeds specification.
ChxData	REAL	Float	Value of analog signal on Channel x after conversion to engineering units.
CSTimestamp	DINT (2)	Decimal	64-bit Coordinated System Time. Timestamp that is taken at the time the input data was sampled in terms of coordinated system time, which is a 64-bit value in microseconds coordinated across the modules in the 1756 backplane.
RollingTimestamp	INT	Decimal	15-bit time from power on/reset in milliseconds. This value is updated when the Output Table changes. If ramping is enabled the value continuously updates until the output value reaches the user value. If the module has entered a faulted state, updated continuously.
HART	AB:1756_OF8IH_HARTData:I:1		
ChxDeviceStatus (Ch0...Ch7)	AB:1756_OF8IH_HARTStatus_Struct:I:1		
Init	BOOL	Decimal	Initializing device.
Fail	BOOL	Decimal	Communication not established.
MsgReady	BOOL	Decimal	Ladder passthrough message reply ready.
CurrentFault	BOOL	Decimal	Digital and analog values do not match.
ConfigurationChanged	BOOL	Decimal	The Field Device configuration has changed and new Field Device configuration information can be obtained from the 1756-OF8IH module via CIP MSG GetDeviceInfo, which clears this bit.

Table 73 - 1756-OF8IH Input Tags - Analog and HART PV Data Format (AB:1756_OF8IH_HARTPV:I:1)

Member Name	Type	Style	Description
ResponseCode	INT	Binary	HART communication status byte or Response code from a recent HART reply (first status byte). See Response Code and Field Device Status on page 229 for more information.
FieldDeviceStatus	INT	Binary	HART device status byte from a recent HART reply. Indicates the health of the HART field device. See Field Device Status Bit Mask Definitions on page 230 for more information.
PVOutOfLimits	BOOL	Decimal	The primary variable is beyond its operating limit.
VariableOutOfLimits	BOOL	Decimal	A device variable that is not mapped to the PV is beyond its operating limits.
CurrentSaturated	BOOL	Decimal	The loop current has reached its upper or lower endpoint limit and cannot increase or decrease any further.
CurrentFixed	BOOL	Decimal	The loop current is being held at a fixed value and is not responding to process variations.
MoreStatus	BOOL	Decimal	More status information is available via command 48, 'Read Additional Status' information.
ColdStart	BOOL	Decimal	A power failure or device reset occurred.
Changed	BOOL	Decimal	An operation was performed that changed the configuration of the device.
Malfunction	BOOL	Decimal	The device detected a serious error or failure that compromises device operation.
ExtDeviceStatus	INT	Binary	Extended device status (from HART cmd9)xx.
MainenanceRequired	BOOL	Decimal	
DeviceVariableAlert	BOOL	Decimal	Device reports a problem with some measurement.
PowerLow			Low power.
ChxPV (Ch 0...Ch7)			Channel x HART PV value.
ChxSV (Ch 0...Ch7)			Channel x HART SV value.
ChxTV (Ch 0...Ch7)			Channel x HART TV value.
ChxFV (Ch 0...Ch7)			Channel x HART FV value.
ChxPVStatus (Ch 0...Ch7)			Channel x HART PV status. See HART PV, SV, TV, and FV Status on page 236 for more information.
ChxSVStatus (Ch 0...Ch7)			Channel x HART SV status. See HART PV, SV, TV, and FV Status on page 236 for more information.
ChxTVStatus (Ch 0...Ch7)			Channel x HART TV status. See HART PV, SV, TV, and FV Status on page 236 for more information.
ChxFVStatus (Ch 0...Ch7)			Channel x HART FV status. See HART PV, SV, TV, and FV Status on page 236 for more information.

Analog and HART by Channel, Configure HART Device = No

[Table 74](#) describes the input tags available in the Analog and HART by Channel data format for the 1756-OF8IH module when Configure HART Device = No.

Table 74 - 1756-OF8IH Input Tags - Analog and HART by Channel, Configure HART Device = No (AB:1756_OF8IH_AnalogHARTbyChannel:I:0)

Member Name	Type	Style	Description
ChannelFaults	INT	Binary	Channel level fault status bits.
ChxFault (Ch 0...Ch7)	BOOL	Decimal	A fault has occurred on the corresponding channel.
LoopOutputFault	BOOL	Decimal	(ChannelFaults.8) Loop output failure. Set when 24V DC backplane power is below 17.5V ($\pm 1.2V$).
ModuleFaults	INT	Binary	Module level fault status bits.
CalFault	BOOL	Decimal	(ModuleFaults.1) Most recent calibration failed.
Calibrating	BOOL	Decimal	(ModuleFaults.2) Calibration in progress.
UpdatedStatusReady	BOOL	Decimal	(ModuleFaults.3) Updated Cmd48 status data available.

Table 74 - 1756-OF8IH Input Tags - Analog and HART by Channel, Configure HART Device = No (AB:1756_OF8IH_AnalogHARTbyChannel:I:0)

Member Name	Type	Style	Description
AnalogGroupFault	BOOL	Decimal	(ModuleFaults.7) Indicates that a channel fault has occurred.
Chx (Ch0...Ch7)	AB:1756_OF8IH_HARTDataAll_Struct:I:0		
Data	REAL	Float	Analog value in engineering units.
Device Status	AB:1756_OF8IH_HARTStatusAll_Struct:I:0		
HARTInit	BOOL	Decimal	Searching for or Initializing HART device. If this is 0 and HARTCommFail is 1, then HART is not enabled on this channel. If both are 1, then 1756-OF8IH is sending out HART messages to attempt to establish communication with a HART device.
HARTCommFail	BOOL	Decimal	HART communication failure, device not found, or HART not enabled. If this bit is 1, none of the other data in the HART part of the Input Tag are valid. (HART.PVStatus is also set to 0 to indicate this).
MsgReady	BOOL	Decimal	Ladder passthrough message reply is ready for query service.
CurrentFault	BOOL	Decimal	Digital and analog values do not match (Analog current measurement does not match the current the Field Device reported over the HART network).
ConfigurationChanged	BOOL	Decimal	The Field Device configuration has changed and new Field Device configuration information can be obtained from the 1756-OF8IH module via CIP MSG GetDeviceInfo, which clears this bit.
BrokenWire	BOOL	Decimal	Indicates that current is not flowing through the module as expected. Broken wiring, RTB removal, or a powered-off field device can cause this.
HARTFault	BOOL	Decimal	Indicates a problem with HART data from the field device on Channel x. Examples are HART not enabled, HART device not connected, HART communication failure due to noise. These field device status conditions also cause this to be set: Device Malfunction, PV Out of Limits, Loop Current Saturated, and Loop Current Fixed.
ResponseCode	SINT	Binary	HART communication status byte or Response code from a recent HART reply (first status byte). See Response Code and Field Device Status on page 229 for more information.
FieldDeviceStatus	SINT	Binary	Field device status byte (second status byte).
PVOutOFLimits	BOOL	Decimal	The primary variable is beyond its operating limit.
VariableOutOflimits	BOOL	Decimal	A device variable that is not mapped to the PV is beyond its operating limits.
CurrentSaturated	BOOL	Decimal	The loop current has reached its upper or lower endpoint limit and cannot increase or decrease any further.
CurrentFixed	BOOL	Decimal	The loop current is being held at a fixed value and is not responding to process variations.
MoreStatus	BOOL	Decimal	More status information is available via command 48, 'Read Additional Status' information.
ColdStart	BOOL	Decimal	A power failure or device reset occurred.
Changed	BOOL	Decimal	An operation was performed that changed the configuration of the device.
Malfunction	BOOL	Decimal	The device detected a serious error or failure that compromises device operation.
ChxStatus (Ch0...Ch7)	SINT	Binary	
HLimitAlarm	BOOL	Decimal	User value equal to or greater than HighLimit configuration value. Automatically set to zero when AlarmDisable config bit is set.
LLimitAlarm	BOOL	Decimal	User value equal to or greater than the LowLimit configuration value. Automatically set to zero when AlarmDisable config bit is set.
RampAlarm	BOOL	Decimal	Set when Output is ramping to new user value. Cleared when ramping complete. This bit is not set if MaxRampRate config value is 0. Automatically set to zero when the AlarmDisable config bit is set.
InHold	BOOL	Decimal	If the HoldForNit config bit is set, the module is waiting for the appropriate Output word.
CalFault	BOOL	Decimal	Set when calibration is invalid for this channel.
NotANumber	BOOL	Decimal	Set when Output word has all 8 bits set (bits 23...30).
OpenWire	BOOL	Decimal	Set when Output is commanded to at least 0.1 mA and the circuit is physically open. Open circuit indication can also exist if the load resistance exceeds specification.
ExtDeviceStatus	SINT	Binary	Extended device status (from HART cmd9).
MaintenanceRequired	BOOL	Decimal	
DeviceVariableAlert	BOOL	Decimal	Device reports a problem with some measurement.

Table 74 - 1756-OF8IH Input Tags - Analog and HART by Channel, Configure HART Device = No (AB:1756_OF8IH_AnalogHARTbyChannel:I:0)

Member Name	Type	Style	Description
PowerLow	BOOL	Decimal	
PV	REAL	Float	HART device primary value.
SV	REAL	Float	HART device second value.
TV	REAL	Float	HART device third value.
FV	REAL	Float	HART device fourth value.
PVStatus	SINT	Hex	HART device PV status.
SVStatus	SINT	Hex	HART device SV status.
VStatus	SINT	Hex	HART device TV status.
FVStatus	SINT	Hex	HART device FV status.
CSTimestamp	INT (2)	Hex	64-bit Coordinated System Time. Timestamp that is taken at the time the input data was sampled in terms of coordinated system time, which is a 64-bit value in microseconds coordinated across the modules in the 1756 backplane.
RollingTimestamp	INT	Decimal	15-bit time from power on/reset in milliseconds. This value is updated when the Output Table changes. If ramping is enabled the value continuously updates until the output value reaches the user value. If the module has entered a faulted state, updated continuously.

Analog and HART by Channel, Configure HART Device = Yes

[Table 75](#) describes the input tags available in the Analog and HART by Channel data format for the 1756-OF8IH module when Configure HART Device = Yes.

Table 75 - 1756-OF8IH Input Tags - Analog and HART PV by Channel, Configure HART Device = Yes (AB:1756_OF8IH_AnalogHARTbyChannel_1:I:0)

Member Name	Type	Style	Description
ChannelFaults	INT	Binary	Channel level fault status bits.
ChxFault	BOOL	Decimal	A fault has occurred on the corresponding channel.
LoopOutputFault	BOOL	Decimal	(ChannelFaults.8) Loop output failure. Set when 24V DC backplane power is below 17.5V ($\pm 1.2V$).
ModuleFaults	INT	Binary	Module level fault status bits.
CalFault	BOOL	Decimal	(ModuleFaults.1) Most recent calibration failed.
Calibrating	BOOL	Decimal	(ModuleFaults.2) Calibration in progress.
UpdatedStatusReady	BOOL	Decimal	(ModuleFaults.3) Updated Cmd48 status data available.
AnalogGroupFault	BOOL	Decimal	(ModuleFaults.7) Indicates that a channel fault has occurred.
Chx (Ch0...Ch7)	AB:1756_OF8IH_HARTDataAll_1_Struct:I:0		
Data	REAL	Float	Analog value in engineering units.
Device Status	AB:1756_OF8IH_HARTStatusAll_1_Struct:I:0		
HARTInit	BOOL	Decimal	Searching for or Initializing HART device. If this value is 0 and HARTCommFail is 1, then HART is not enabled on this channel. If both are 1, then 1756-OF8IH is sending out HART messages to attempt to establish communication with a HART device.
HARTCommFail	BOOL	Decimal	HART communication failure, device not found, or HART not enabled. If this bit is 1, none of the other data in the HART part of the Input Tag are valid. (HART.PVStatus is also set to 0 to indicate this.)
MsgReady	BOOL	Decimal	Ladder passthrough message reply is ready for query service.
CurrentFault	BOOL	Decimal	Digital and analog values do not match (analog current measurement does not match the current the Field Device reported over the HART network).

Table 75 - 1756-OF8IH Input Tags - Analog and HART PV by Channel, Configure HART Device = Yes (AB:1756_OF8IH_AnalogHARTbyChannel_1:I:0)

Member Name	Type	Style	Description
ConfigurationChanged	BOOL	Decimal	The Field Device configuration has changed and new Field Device configuration information can be obtained from the 1756-OF8IH module via CIP MSG GetDeviceInfo, which clears this bit.
Unused1	BOOL	Decimal	
HARTFault	BOOL	Decimal	Indicates a problem with HART data from the field device on Channel x. Examples are HART not enabled, HART device not connected, HART communication failure due to noise. These field device status conditions also cause this to be set: Device Malfunction, PV Out of Limits, Loop Current Saturated, and Loop Current Fixed.
ResponseCode	SINT	Binary	HART communication status byte or Response code from a recent HART reply (first status byte). See Response Code and Field Device Status on page 229 for more information.
FieldDeviceStatus	SINT	Binary	Field device status byte (second status byte).
PVOutOfLimits	BOOL	Decimal	The primary variable is beyond its operating limit.
VariableOutOfLimits	BOOL	Decimal	A device variable that is not mapped to the PV is beyond its operating limits.
CurrentSaturated	BOOL	Decimal	The loop current has reached its upper or lower endpoint limit and cannot increase or decrease any further.
CurrentFixed	BOOL	Decimal	The loop current is being held at a fixed value and is not responding to process variations.
MoreStatus	BOOL	Decimal	More status information is available via command 48, 'Read Additional Status' information.
ColdStart	BOOL	Decimal	A power failure or device reset occurred.
Changed	BOOL	Decimal	An operation was performed that changed the configuration of the device.
Malfunction	BOOL	Decimal	The device detected a serious error or failure that compromises device operation.
ChStatus	SINT	Binary	
RampAlarm	BOOL	Decimal	(ChStatus.2) Set when Output is to a new user value. Cleared when ramping complete. This bit is not set if MaxRampRate config value is 0. Automatically set to zero when the AlarmDisable config bit is set.
InHold	BOOL	Decimal	(ChStatus.3) If the HoldForNit config bit is set, the module is waiting for the appropriate Output word.
CalFault	BOOL	Decimal	(ChStatus.4) Set when calibration is invalid for this channel.
NotANumber	BOOL	Decimal	(ChStatus.5) Set when Output word has all 8 bits set (bits 23...30).
PVConfigFailed	BOOL	Decimal	(ChStatus.6)
OpenWire	BOOL	Decimal	(ChStatus.7) Set when Output is commanded to at least 0.1 mA and the circuit is physically open. Open circuit indication can also exist if the load resistance exceeds specification.
ExtDeviceStatus	SINT	Binary	Extended device status (from HART cmd9).
MaintenanceRequired	BOOL	Decimal	(ExtDeviceStatus.0)
DeviceVariableAlert	BOOL	Decimal	(ExtDeviceStatus.1) Device reports a problem with some measurement.
PowerLow	BOOL	Decimal	(ExtDeviceStatus.2)
CalibrationFault	BOOL	Decimal	Last attempted calibration for this channel failed.
Calibrating	BOOL	Decimal	Calibration for the channel is in progress.
CalGoodLowRef	BOOL	Decimal	A valid Low Reference signal has been sampled on this channel.
CalBadLowRef	BOOL	Decimal	The Low Reference signal is grossly out of the expected range.
CalGoodHighRef	BOOL	Decimal	A valid high reference signal has been sampled on the channel.
CalBadHighRef	BOOL	Decimal	The high reference signal is grossly out of the expected range.
CalSuccessful	BOOL	Decimal	This bit is set after valid High and Low points are captured and the Calibrate bit in the output word has been cleared.
PV	REAL	Float	HART device primary value.
SV	REAL	Float	HART device second value.
TV	REAL	Float	HART device third value.
FV	REAL	Float	HART device fourth value.
PVStatus	SINT	Hex	HART device PV status.

Table 75 - 1756-OF8IH Input Tags - Analog and HART PV by Channel, Configure HART Device = Yes (AB:1756_OF8IH_AnalogHARTbyChannel_1:I:0)

Member Name	Type	Style	Description
SVStatus	SINT	Hex	HART device SV status.
VStatus	SINT	Hex	HART device TV status.
FVStatus	SINT	Hex	HART device FV status.
CSTimestamp	INT (2)	Hex	64-bit Coordinated System Time. Timestamp that is taken at the time the input data was sampled in terms of coordinated system time, which is a 64-bit value in microseconds coordinated across the modules in the 1756 backplane.
RollingTimestamp	INT	Decimal	15-bit time from power on/reset in milliseconds. This value is updated when the Output Table changes. If ramping is enabled the value continuously updates until the output value reaches the user value. If the module has entered a faulted state, updated continuously.

Output, Configure HART Device = No

[Table 76](#) describes the output tags available in the 1756-OF8IH module when Configure HART Device is set to No.

Table 76 - 1756-OF8IH Output Tags, Configure HART Device = No (AB:1756_OF8H:0:0)

Member Name	Type	Style	Description
ChxData (Ch0...Ch7)	REAL	Float	Value in engineering units to output on the analog signal of Channel x.

Output, Configure HART Device = Yes

[Table 77](#) describes the output tags available in the 1756-OF8IH module when Configure HART Device is set to Yes.

Table 77 - 1756-OF8IH Output Tags, Configure HART Device = Yes (AB:1756_OF8IH:0:0)

Member Name	Type	Style	Description
Ch	AB:1756_OF8IH_ChStruct:0:0[8]		
Chx (Ch0...Ch7)	AB:1756_OF8IH_ChStruct:0:0		
Calibrate	BOOL	Decimal	Bit 0 - Initiates the calibration process. Must stay set through a valid LowReference and HighReference sequence. Clearing this bit before this sequence is complete aborts calibration.
CalOutputLowRef	BOOL	Decimal	Bit 1 - Rising edge sets output to low calibration value (4 mA).
CalOutputHighRef	BOOL	Decimal	Bit 2 - Rising edge sets output to high calibration value (20 mA).
CalLowRefPassed	BOOL	Decimal	Bit 3 - On rising edge, the value in ChxData represents the measured low cal output in mA.
CalHighRefPassed	BOOL	Decimal	Bit 4 - On rising edge, the value in ChxData represents the measured high cal output in mA.
CalFinished	BOOL	Decimal	Bit 5 - Rising edge triggers channel to use the High and Low reference measurements for calculating the calibration. Calibration state exits if successful.
ChData	REAL	Float	Value in engineering units to output on the analog signal of Channel x.
CalibrationDate	INT	Decimal	The date to be recorded upon successful calibration, typically the current date.

Notes:

Configure Modules in the Logix Designer Application

This chapter discusses these topics.

Topic	Page
Create a New Module	145
General Tab	147
Connection Tab	149
Module Info Tab	149
Configuration Tab - Input Modules	151
Alarm Tab - 1756-IF8H and 1756-IF8IH Modules	158
Configuration Tab - Output Module	160
Output State Tab - Output Module	162
Limits Tab - 1756-OF8H and 1756-OF8IH Modules	164
HART Device Info Tab	165
Data in the Input Tags	170

Create a New Module

Do these steps to add a ControlLogix® HART analog I/O module to your Studio 5000 Logix Designer® application project.

The screenshots show examples for the 1756-IF8IH or 1756-IF8H module, but the procedures are similar for all HART analog I/O modules.

IMPORTANT You cannot change any field in these tabs if you are in Hard Run mode. Hard Run mode means that the keyswitch is in the Run position.

1. From the I/O Configuration tree, right-click the 1756 backplane and choose New Module.

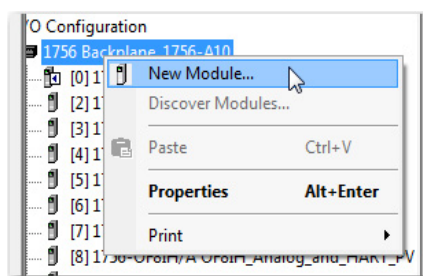

The Select Module Type dialog appears.

2. In the Select Module Type dialog, find and select the module that you want to add.

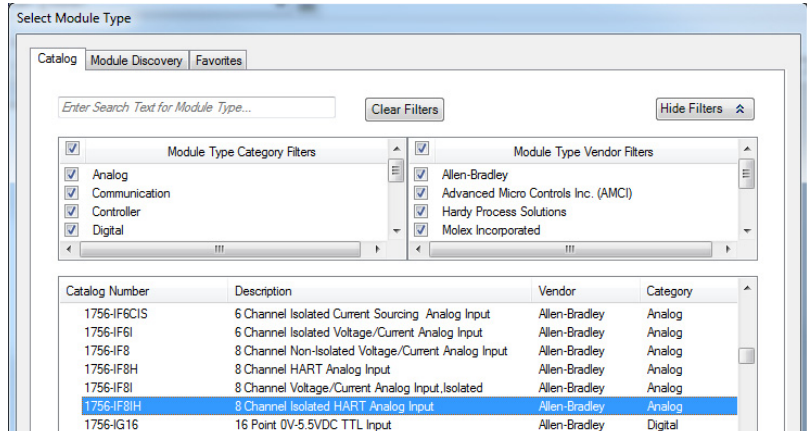

3. Click Create.

The New Module dialog box is displayed.

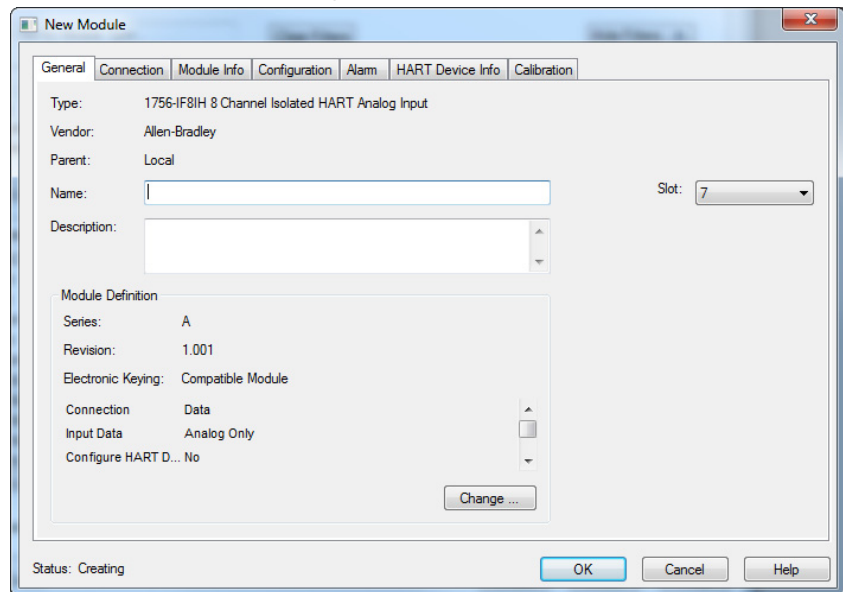

General Tab

Complete these instructions for general configuration.

1. On the General tab, do these steps:
 - a. Type a name for the module.
 - b. Optionally, type a description for the module.
 - c. Select the slot number for the module.
2. In the Module Definition box, click Change.

The Module Definition dialog appears.

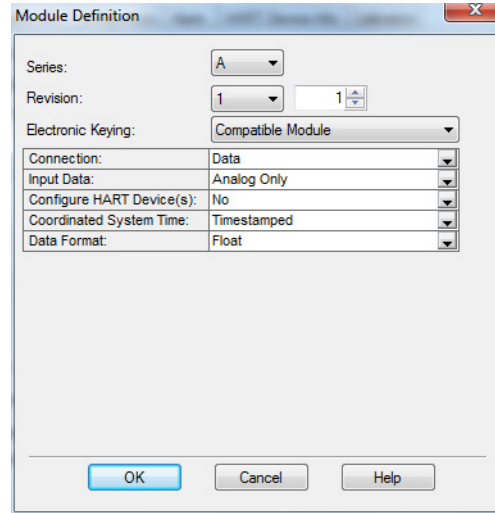

3. Complete these actions:

Parameter	Action	Values
Series	Select the series letter that matches the label on the side of your module.	Pull-down menu
Revision	Select the revision number that matches the label on the side of your module; make sure that the minor revision number also matches.	Pull-down menu
Electronic Keying	Choose the electronic keying method See Electronic Keying on page 20 for more information	<ul style="list-style-type: none"> • Exact Match • Compatible Module (default) • Disable Keying
Connection	Choose the connection type	<ul style="list-style-type: none"> • Data - has more tabs on the Module Properties dialog box than Listen-only because of configuration settings for alarms, calibration • Listen-only - has no configuration data, does not send output data See Listen-only Mode on page 30 for more information.
Input Data	Choose the input data mode	<ul style="list-style-type: none"> • Analog Only • Analog and HART PV • Analog and HART by Channel See HART Configuration for more information.
Configure HART Device	Select whether to enable the Configure HART Device feature. This feature is available only for the 1756-IF8IH and 1756-OF8IH modules when data format is Analog and HART by Channel. If you select Yes, a HART Command tab is added to the configuration dialog, in which you specify configuration values to be sent to the HART device.	Values that can be added in the HART Command tab are PV Damping (seconds), PV Units, PV Upper Range, PV Lower Range, PV Transfer Function.
Coordinated System Time	Not configurable	Timestamped
Data Format	Not configurable	Float

HART Configuration

The Input Data selection that you make in the Module Definition dialog determines how HART field device data can be accessed. Access the Module Definition dialog from the General tab.

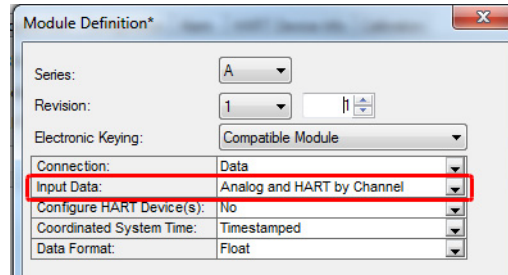

HART field device data is gathered through automatic collection of HART Field Device Process Variables and Health information. You can also access HART field device data with pass-through messages. See [Use a CIP MSG to get HART Data on page 177](#) and [HART Modules Used with Asset Management Software on page 199](#) for more information.

[Table 78](#) shows which configuration options provide HART data in the input tag and which provide pass-through message access.

Table 78 - HART Data Configuration Options

Input Data Format	Enable HART Checkbox (Configuration Tab)	HART Data Input Tag Present?	Pass-through Message Access for MSG or Asset Management
Analog only	Not checked	No	No
	Checked		Yes
Analog and HART PV	Not checked	Fields present in tag, but data for this channel not valid	No
	Checked	Yes	Yes
Analog and HART by Channel	Not checked	Fields present in tag, but data for this channel not valid	No
	Checked	Yes	Yes

Even if you are not enabling HART on all channels, the Analog and HART PV input tag includes space for the data. However, this data space is marked with a HART Fault to indicate that the data is not valid. This feature lets you add HART instruments later without disturbing the tag layout.

Connection Tab

Use the following information to make selections on the Connection tab.

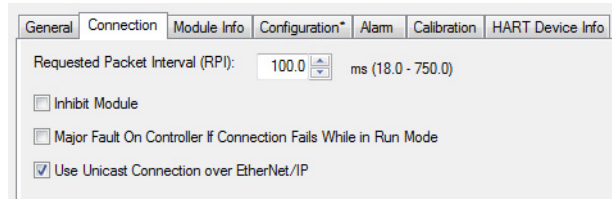

Parameter	Description
Requested Packet Interval	Defines when the module multicasts its data onto the local chassis backplane.
Inhibit Module	Prevents connection to the module. Use only if you do not want the module to be put into service.
Major Fault on Controller If Connection Fails While in Run Mode	The Logix controller performs a major fault if communication to this I/O module fails.
Use Unicast Connection over EtherNet/IP	Appears only for HART analog modules that use the Logix Designer application version 18 or later in a remote EtherNet/IP chassis. Use the default checkbox if there are no other controllers in 'Listen-Only' mode. Clear the box if there are other 'listening' controllers in the system.

Module Info Tab

The Module Info tab displays module and status information. This tab is populated with data that comes directly from the module. The information on this window is displayed when the project is online.

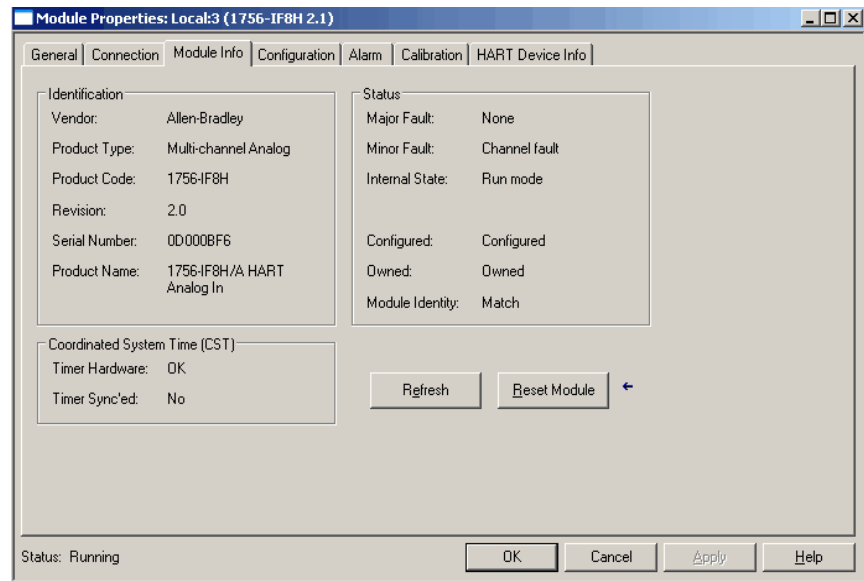

Status

The Status box in the right-hand column of the Module Info tab displays the current operational stats of the module. See the descriptions in the following table.

Parameter	Description						
Major Fault	None, Unrecoverable, or Recoverable.						
Minor Fault	None, Unrecoverable, or Recoverable. Recoverable can mean that you have a channel fault such as wire off.						
Internal State	Indicates the module mode.						
Configured	Indicates if an owner controller that is connected to the module configured the module. Once a module is configured, it stays configured until the module is reset or power is cycled, even if the owner drops connection to the module. ⁽¹⁾						
Owned	Indicates if an owner controller is connected to the module. ⁽¹⁾						
Module Identity	Displays Match or Mismatch as described in the table. This field does not account for the Electronic Keying or Minor Revision selections for the module as specified on the General tab.						
	<table border="1"> <thead> <tr> <th>Displays</th> <th>If the Physical Module</th> </tr> </thead> <tbody> <tr> <td>Match</td> <td>Agrees with what is specified on the General tab. For the Match condition to exist, the following items must agree: <ul style="list-style-type: none"> • Vendor • Module type (the combination of product type and product code for a particular vendor) • Major revision </td> </tr> <tr> <td>Mismatch</td> <td>Does not agree with what is specified on the General tab.</td> </tr> </tbody> </table>	Displays	If the Physical Module	Match	Agrees with what is specified on the General tab. For the Match condition to exist, the following items must agree: <ul style="list-style-type: none"> • Vendor • Module type (the combination of product type and product code for a particular vendor) • Major revision 	Mismatch	Does not agree with what is specified on the General tab.
	Displays	If the Physical Module					
Match	Agrees with what is specified on the General tab. For the Match condition to exist, the following items must agree: <ul style="list-style-type: none"> • Vendor • Module type (the combination of product type and product code for a particular vendor) • Major revision 						
Mismatch	Does not agree with what is specified on the General tab.						
Mismatch	Does not agree with what is specified on the General tab.						

(1) This information applies to the I/O module only and does not apply to adapters, scanners, bridges, or other communication modules.

Coordinated System Time (CST)

The CST box in the lower, left-hand column of the Module Info tab provides the following information.

Parameter	Description
Timer Hardware	Displays OK or faulted for the timer hardware.
Timer Sync'ed	Displays yes if the module timer is coordinated with the master. Displays no if it is not. This indicates if a CST master is providing a time reference to the module. Configure a controller to be the CST Time Master on the Controller Properties tab.

Refresh or Reset Module

Click Refresh to refresh the information or click Reset Module to reset the module to its power-up state.

IMPORTANT Resetting the module breaks connections and restores output signals to default conditions.

Apply Changes

If the following conditions exist when you click Apply or OK, the information is automatically sent to the controller:

- You are online in Program, Remote Program, or Remote Run mode, and
- This controller is the owner controller, and
- You have changed the module configuration in the software.

The controller tries to send the information to the module (if the module connection is not inhibited). If you do not click OK or Apply, your changes are not sent to the controller.

Configuration Tab - Input Modules

The following information describes how to configure the module input channels. Differences among the modules are noted.

Changes made to the parameters in the Channel box apply only to the individual channel that is selected.

Changes made to these parameters apply to all channels.

Configure Individual Channels

With an individual channel button selected, use this table to configure the parameters in the Channel box that apply to the individual channels.

Parameter	Action	Notes	Available in Hard Run Mode?
Enable HART	Check or uncheck for the selected channel.	<ul style="list-style-type: none"> If HART is enabled, input range must be 0...20 mA or 4...20 mA. When HART is not enabled for a channel: <ul style="list-style-type: none"> HART messages are not sent on this channel. HART pass-through messages are not sent. HART data for this channel is not updated in the input tag. If you select a HART PV or HART by Channel input tag on the General tab, process data (PV, SV, TV, and FV) from the HART instrument is included in the input tag. If you selected Analog only, the additional process data is not included in the input tag. Regardless of the choice of input tag, HART communication can be enabled for each channel to provide pass-through HART message access. If Enable HART is not checked, this pass-through message access is not available. We recommend that you Enable HART for any channel that has a connected HART device. This selection is so that information can be displayed on the HART Device Info tab and accessed by FactoryTalk® AssetCentre software. You can check Enable HART on some channels and not on others if only some channels have HART field devices attached. On the 1756-IF8H and 1756-OF8H modules, all channels share the HART modem. For these modules, HART response time is better if you enable only the needed HART channels. The other modules (1756-IF16H, 1756-IF16IH, 1756-IF8IH, and 1756-OF8IH) have a separate HART modem for each channel. 	No
Scaling	Enter values for High Signal, Low Signal, High Engineering, and Low Engineering.	See Scaling to Engineering Units on page 153 for more information.	No
Input Range	Choose a value from the pull-down menu.	<ul style="list-style-type: none"> 0...20 mA or 4...20 mA is required for HART. The 1756-IF8IH and 1756-OF8IH do not support voltage ranges. 	No
Sensor Offset	Enter a value from -9,999,999...99,999,999 (float).	<ul style="list-style-type: none"> The default value is 0.00. The offset value is in engineering units. The Sensor Offset is added to the data value to determine signal level. 	No
Digital Filter	Select a filter time constant value from 0...20100 ms.	This field is a first-order lag filter that smooths input transitions. It is called a digital filter because it is calculated in the software by the module, not by a hardware filter. Each channel has its own digital filter value. So each channel can have a unique digital filter setting to accommodate the specific device that is attached to that channel. For the module filter, one value is applied for all channels.	No

For descriptions of the other boxes, such as Real Time Sample (RTS), see [Configure All Channels on page 156](#).

Scaling to Engineering Units

Channel data values in the output tag can be in engineering units such as kg, m, or percent. To configure the relationship between engineering units and the physical signal in volts or mA, set the Low and High Signal and the Low and High Engineering values.

For example, suppose that you have a temperature transmitter that produces 4 mA current at -180 °C and 20 mA current at +750 °C. If you want to use °C in your control program, configure the values as in the following table.

	Signal	Engineering
High	20	750
Low	4	-180

If you are using HART field devices, we recommend setting Engineering High and Low to the field device Upper Range and Lower Range Values. This selection is so that the field device and module use the same engineering units. If online, these values are displayed on the HART Device Info tab.

See the [Example of Scaling on page 154](#) for more information.

Scaling High and Low Signal

Set the High and Low Signal values for the module. The High Signal value must be greater than the Low Signal value. See the following table for the bounds of these signals.

Range ⁽¹⁾	Low Limit	High Limit
-10...10V	-10.00	10.00
0...20 mA	0.00	20.00
4...20 mA	4.00	20.00
0...5V	0.00	5.00
0...10V	0.00	10.00

(1) Voltage ranges are not available in 1756-IF8IH and 1756-OF8IH modules.

Scaling High Engineering

Set the High Engineering value for the module. The High Engineering value must not equal the Low Engineering value. This value is in engineering units and corresponds with a signal value equal to the High signal.

Valid values are in the range of -10,000,000...100,000,000. The default value is 100.00.

Scaling High Engineering appears dimmed in Hard Run mode.

Scaling Low Engineering

Set the Low Engineering value for the module. The Low Engineering value must not equal the High Engineering value. This value is in engineering units and corresponds with a signal value equal to the Low signal.

Valid values are in the range of -10,000,000...100,000,000. The default value is 0.00.

Example of Scaling

To configure the module to tell you how full a tank is, configure scaling to give you 0% when the tank is empty and 100% when the tank is full. Suppose the sensor that measures the tank signals 4.5 mA when the tank is empty and 17 mA when the tank is full. You would configure scaling as shown in this figure.

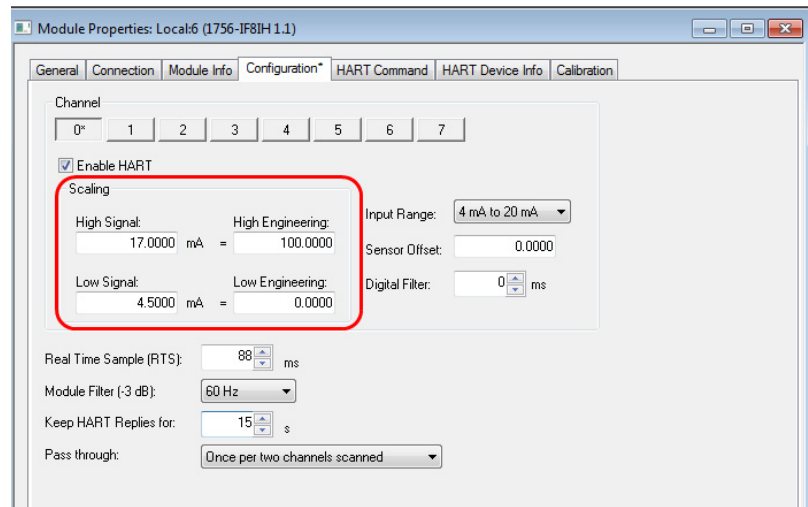

This configuration creates a relationship between the electrical signal that the tank gauge and the number sent to the Logix Controller generates for use in the control system. Graphically, the relationship looks like this figure.

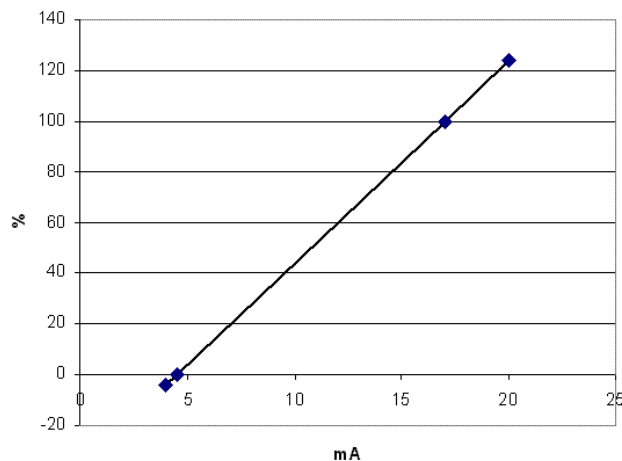

The module can measure signals slightly higher and lower than the sensor provides for this tank. Setting the High or Low Engineering Units does not limit the values to within that range. The module still measures signals from 4...20 mA. In this example, if the module senses 20 mA, it reports that the tank is 124% full. A signal of 0 mA is reported as -4% full, or 'less than empty'.

To have the tank level reported in liters instead of percent, put the capacity of the tank as the High Engineering Unit. If you have a 750 liter tank, as in the previous example, put 750 instead of 100 and you get the scaling relationship shown by this figure.

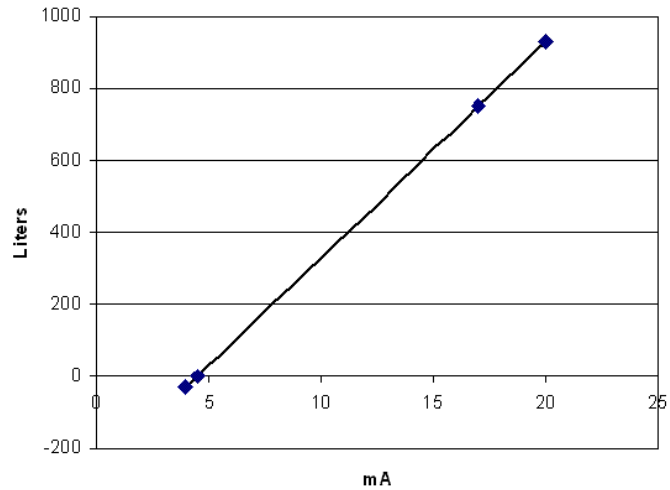

Configure All Channels

Use this table to configure the parameters on the Configuration tab that apply to all channels.

Parameter	Action	Notes	Available in Hard Run Mode?
Real Time Sample (RTS)	Choose a value from 0...10,000 ms.	<ul style="list-style-type: none"> Determines the interval of time at which updated information is supplied to the controller. The default is 88. See Real Time Sample (RTS) on page 23 for more information. See the Real-Time Sample Values table on page 156 for RTS choices available for each Module Filter setting. 	No
Module Filter (-3 dB)	Choose a value from the pull-down menu.	<ul style="list-style-type: none"> Because the digital HART communication signals are in the 1200...2400 Hz range, the module filter cannot be set to 1000 Hz if HART is enabled. See the Module Filter Values table on page 158 to choose a value. See Module Filter on page 35 (1756-IF8H) or page 56 (1756-IF8IH) for more information. 	No
Keep HART Replies	Choose a value from 1...255 s.	<ul style="list-style-type: none"> HART replies that are received from the Field Device in response to pass-through messages that have been sent are kept for this long. Retrieve them within this time or the module discards them. The default is 15. 	No
		IMPORTANT We do not recommend a value of less than 15 s.	
		<ul style="list-style-type: none"> See Use a CIP MSG to get HART Data on page 177 for more information. 	
Pass through	Choose a value from the pull-down menu.	<ul style="list-style-type: none"> Determines how often pass-through messages occur. <ul style="list-style-type: none"> Once per two channels scanned (default)- After two channels have PVs scanned to the input tag, a pass-through message is sent (if one is pending). Once per module scan - Choose this value if you want to minimize the impact pass-through message clients have on reading the PVs into the input tag. Once per channel scan - After each channel has its PVs scanned to the input tag, a pass-through message is sent (if one is pending). Choose this value if you want to give pass-through messages from clients, such as FactoryTalk AssetCentre, higher priority than reading PV, SV, TV, FV, and field device health into the input tag. See the Pass-through Setting, Ratio, and Priority (Input Modules) table on page 156 for more information. 	No

Table 79 - Real-Time Sample Values

Module Filter, Hz	Low Limit, ms	High Limit, ms
10	488	10000
15	328	
20	248	
50	88	
60	88	
100 (default)	56	
250	28	
1000	18	

Table 80 - Pass-through Setting, Ratio, and Priority (Input Modules)

Setting	Scan: Pass-through Ratio	Gives Priority to
Once per channel scan	1:1	Asset management
Once per two channels scanned	1:2	Default setting
Once per module scan	1:8	Input tag scan

Module Resolution

Resolution is the smallest amount of change that the module can detect.

Resolution is sometimes expressed in bits. If 16 bits of resolution are available, the module can detect 65536 different signal values. If configured for 4...20 mA, it could discern the difference between 10...10.0003 mA, but it would not distinguish between 10...10.0002 mA.

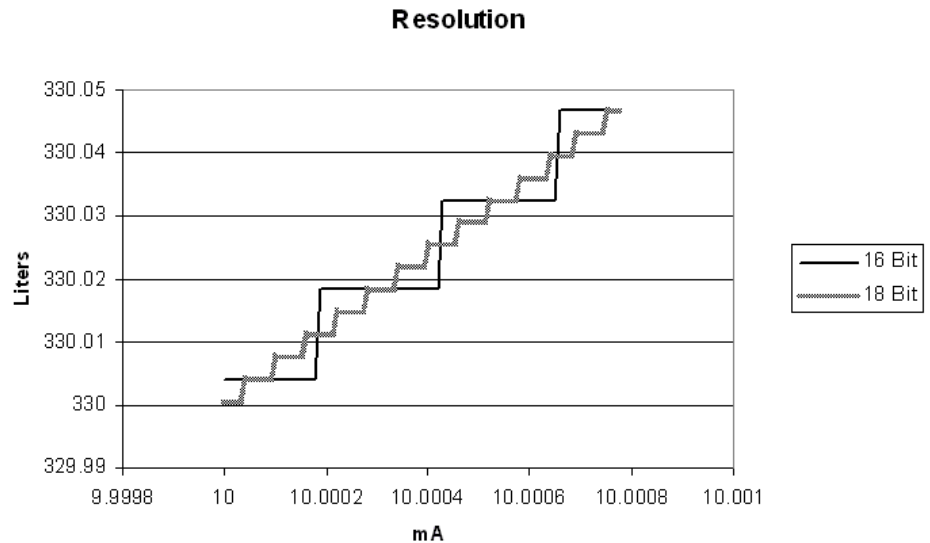

Resolution affects how the module measures analog signals. Scaling converts the analog signal to Engineering Units for convenience in your control system. In the previous 16-bit example and the 750 liter tank example in the previous section, you would have a resulting resolution of 0.0146 liters. As the tank fills, the volume reading could jump from a reading of 250 liters to 250.015 liters without displaying any values between. Because of sampling, filtering, and RPI, you can see more or fewer intermediate values, depending on the fill rate.

The resolution of analog input modules depends on the module and the filter configuration. To measure a rapidly changing signal, a configuration with less resolution is used. For information about the resolution available, see the following locations.

Available Resolution for This Module	Page
1756-IF8H	35
1756-IF8IH	56
1756-IF16H	77
1756-IF16IH	93
1756-OF8H	108
1756-OF8IH	125

IMPORTANT Because these modules must provide for possible calibration inaccuracies, resolution values represent the available analog-to-digital or digital-to-analog counts over the selected range, including a small amount of Overage and Underrange.

Table 81 - Module Filter Values

Module Filter, Hz	C.ModuleFilter
10 ⁽¹⁾	0
15	7
20	6
50	1
60 (default)	2
100	3
250	4
1000 ⁽²⁾	5

- (1) 10 Hz not supported in the 1756-IF16H or 1756-IF16IH modules.
- (2) Do not choose 1000 with HART enabled.

Alarm Tab - 1756-IF8H and 1756-IF8IH Modules

The following information describes how to configure the parameters on the Alarm tab for the 1756-IF8H and 1756-IF8IH modules. For more information, see [Process Alarms on page 38](#) or [page 60](#), and [Rate Alarm on page 39](#) or [page 59](#).

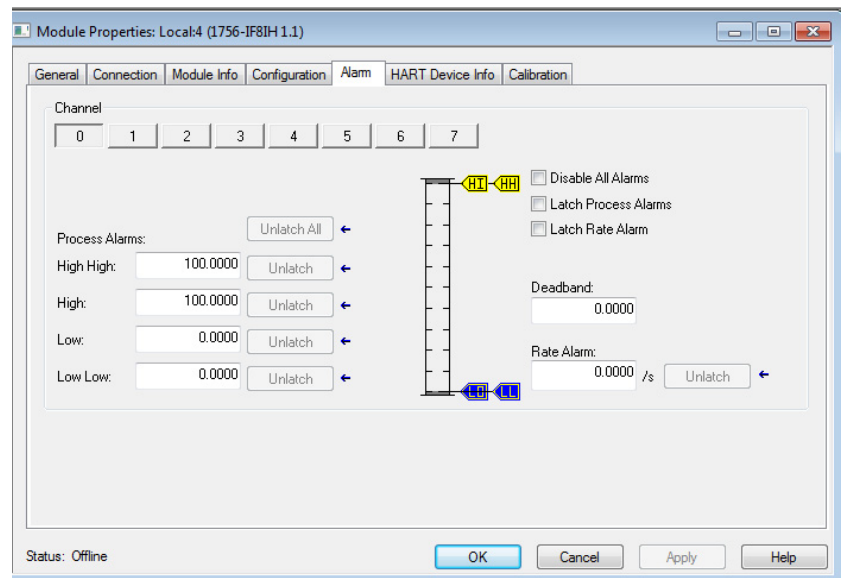

With an individual channel button selected, use these parameter descriptions to configure the alarms.

Table 82 - Alarm Tab Parameters

Parameter	Action	Notes	Available in Hard Run Mode?
Process Alarms	Enter values or drag the corresponding flags on the slider bar to set the values.	<ul style="list-style-type: none"> The High Engineering and Low Engineering parameters on the Configuration tab set the maximum and minimum values for these alarms. Alarm thresholds are in engineering units. To change the trigger points by whole numbers only, hold down the shift key while dragging the flag on the slider bar. A deadband appears around each value. 	No
High High (HH)		<ul style="list-style-type: none"> Sets the level of input to a channel that causes the module to set the High High alarm. The alarm remains active until the input returns below this level by more than the deadband. If Latch Process Alarms is checked, the ChXHHAlarm indication remains set until explicitly cleared. 	
High (HI)		<ul style="list-style-type: none"> Sets the level of input to a channel that causes the module to set the High alarm. The alarm remains until the input returns below this level by more than the deadband. If Latch Process Alarms is checked, the ChXLAlarm indication remains set until explicitly cleared. 	
Low (LO)		<ul style="list-style-type: none"> Sets the level of input on a channel that causes the module to set the Low alarm. The alarm remains until the input returns above this level by more than the deadband. If Latch Process Alarms is checked, the ChXLAlarm indication remains set until explicitly cleared. 	
Low Low (LL)		<ul style="list-style-type: none"> Set the level of input to a channel that causes the module to set a Low Low alarm. The alarm remains until the input returns above this level, more than the deadband. If Latch Process Alarms is checked, the ChXLLAlarm indication remains set until explicitly cleared. 	
Disable All Alarms	Check	Disables all alarms for a channel.	No
Latch Process Alarms	Check	Maintains an alarm triggered condition for any of the process alarms, even after the condition ceases. The alarm unlatches only with an explicit message that acknowledges the alarm.	No
Latch Rate Alarm	Check	When enabled, a Rate Alarm indication remains set, even when the alarm condition returns to normal. This latch lets you maintain the alarm even after the condition ceases. The alarm unlatches only with an explicit message that acknowledges the alarm.	No
Deadband	Enter a value from 0.00 . . . 99,999,999.	<ul style="list-style-type: none"> Select a value at which an alarm, once set, does not disable as long as the input value remains within the deadband range of the alarm trigger point. (This value in combination with the process alarms creates the range.) This configuration prevents the alarm from cycling on and off if the process value hovers near the alarm threshold. The alarm deadband can be only half the distance between high and low alarm limits. The default is 0.00 For related information, see Alarm Deadband on page 38. 	No
Rate Alarm	Enter an alarm limit value from 0.00 . . . 99,999,999.	<ul style="list-style-type: none"> Enter a Maximum Ramp Rate value to trigger a Rate Alarm when the input signal rate of change exceeds the setpoint. This configuraiton is useful for detecting rapid process changes. The default is 0.00 Set this alarm in engineering units/second. 	No
Unlatch All	Click	<ul style="list-style-type: none"> Unlatches all alarms. Is not available when the project is offline. 	Yes
Unlatch	Click	<ul style="list-style-type: none"> Unlatches the adjacent alarm condition. Is not available when the project is offline. 	Yes

Configuration Tab - Output Module

The following information describes how to configure the output channels of the module.

Changes made to the parameters in the Channel box only apply to the individual channel that is selected.

Changes made to these parameters apply to all channels.

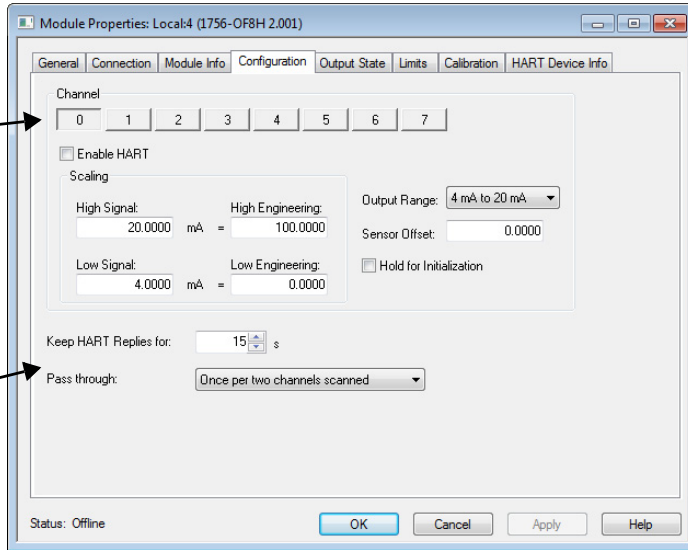

Configure Individual Channels

With an individual channel button selected, use this table to configure the parameters in the Channel box that apply to the individual channels.

Table 83 - Configuration Tab Parameters

Parameter	Action	Notes	Available in Hard Run Mode?
Enable HART	Check or uncheck.	<ul style="list-style-type: none"> Unchecked by default. Output range must be 0...20 mA or 4...20 mA. When a channel is not enabled: <ul style="list-style-type: none"> HART messages are not sent on this channel. HART pass-through messages are not sent. HART data for this channel is not updated in the input tag. If you selected a HART PV or HART by Channel input tag input tag on the General tab, process data (PV, SV, TV, and FV) from the HART instrument is included in the input tag. If you selected Analog only, the process data is not included in the input tag. Regardless of the choice of input tag, HART communication can be enabled for each channel to provide pass-through HART message access. If Enable HART is not checked, this pass-through message access is not available. We recommend you Enable HART for any channel that has a HART device connected so that information can be displayed on the HART Device Info tab. One reason to disable HART communication is that each channel that is enabled requires time to scan, so enabling unnecessary channels reduces performance on the others. 	No
Scaling	Enter scaling values for High Signal, Low Signal, High Engineering, and Low Engineering.	See Scaling to Engineering Units on page 153 for more information.	No

Table 83 - Configuration Tab Parameters

Parameter	Action	Notes	Available in Hard Run Mode?
Output Range	Chose a value from the pull-down menu.	0...20 mA or 4...20 mA is required for HART.	No
Sensor Offset	Enter a value from -9,999,999...99,999,999 (float).	<ul style="list-style-type: none"> The default value is 0.00. The offset value is in engineering units. The Sensor Offset is added to the data value to determine signal level. 	No
Hold for Initialization	Check or uncheck	<ul style="list-style-type: none"> Check this box to cause the module to hold the output signal unchanged until the output value received from the controller in the ChxData field is within 0.1% of full scale of the value being held. The output holds when the following occurs: <ul style="list-style-type: none"> Powerup occurs (holds at zero) A new connection is established (brings it out of fault state and it holds at the fault value from the previous configuration). The controller returns to Run mode after Program mode (continues to hold at the configured value that was held in Program mode, see the Output State tab). The output channel holding lets the controller synchronize with the output, enables smooth output transitions and avoids rapid transients when control resumes from an interruption. The output can be ramping to the configured hold value when the transition occurs. In this case, it continues the ramp until it completes or until the output value from the controller is within the 0.1% of the output signal. When the Hold for Initialization box is not checked, the output switches as quickly as possible to the first value commanded by the controller. 	No

Configure All Channels

Use [Table 84](#) to configure the parameters on the Configuration tab that apply to all channels.

Table 84 - All Channels Configuration Parameters

Parameter	Action	Notes	Available in Hard Run Mode?
Keep HART Replies	Select a value from 1...255 s.	<ul style="list-style-type: none"> HART pass-through message replies are kept for this time. HART replies that are received from the Field Device in response to pass-through messages you have sent are kept for this long. You must retrieve them within this time or the module discards them. The default is 15. 	No
		IMPORTANT We do not recommend a value of less than 15 s.	
Pass through	Choose a value from the pull-down menu.	<ul style="list-style-type: none"> Determines how often pass-through messages occur. <ul style="list-style-type: none"> Once per two channels scanned (default)- After 2 channels have PVs scanned to the input tag, a pass-through message is sent (if one is pending). Once per module scan - Choose this value if you want to minimize the impact pass-through message clients have on reading the PVs into the input tag. Once per channel scan - After each channel has its PVs scanned to input tag, a pass-through message is sent (if one is pending). Choose this value if you want to give pass-through messages from clients such as FactoryTalk AssetCentre higher priority than reading PV, SV, TV, FV, and field device health into the input tag. See the Pass-through Setting, Ratio, and Priority (Output Modules) table on page 161 for more information. 	No

Table 85 - Pass-through Setting, Ratio, and Priority (Output Modules)

Setting	Scan:Pass-through ratio	Gives priority to
Once per channel scan	1:1	Asset management
Once per two channels scanned	1:2	Default setting
Once per module scan	1:8	Input tag scan

Output State Tab - Output Module

The 1756-OF8H and 1756-OF8IH modules have an Output State tab. Use the following information to configure the parameters on the Output State tab.

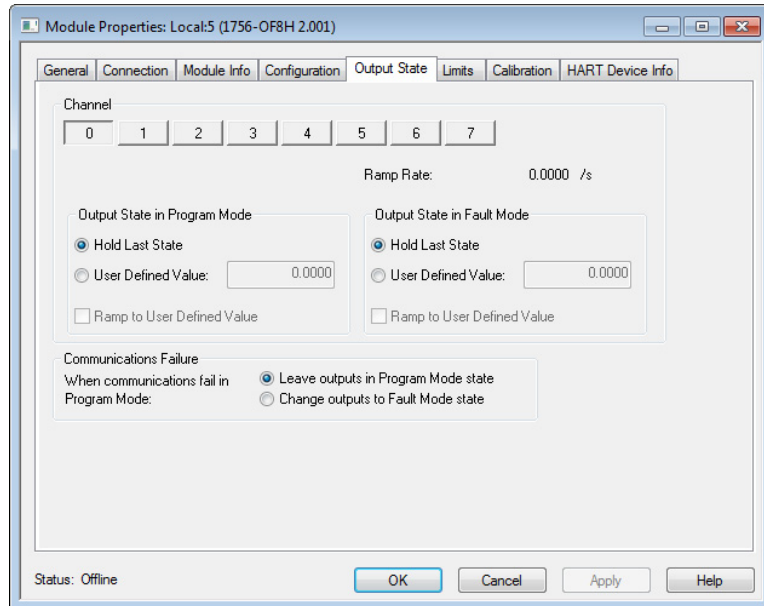

With an individual channel button selected, use this information to configure the parameters in the Channel box that apply to the individual channels.

Ramp Rate

The Ramp Rate limits the speed at which an analog output signal can change. This value prevents fast transitions in output from damaging equipment that the output controls. This feature is available in Hard Run mode. Ramping in Run mode and the ramp rate are set on the Limits tab.

For the 1756-OF8IH module with Configure HART Device set to Yes, ramping in Run mode and ramp rate are set on the Output State tab.

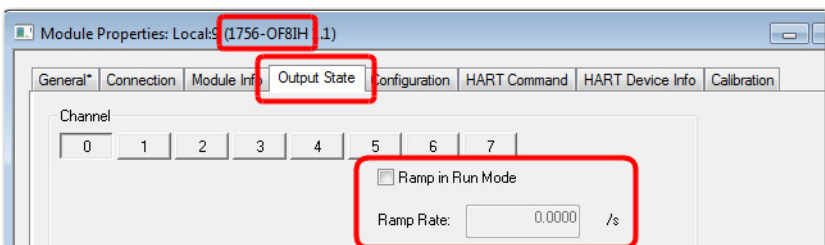

Output State in Program Mode

These parameters are not available in Hard Run mode.

Selecting	Configures the Output Channel for the Following When the Controller Transitions from Run to Program Mode
Hold Last State	Leave the current output at its last value.
User-Defined Value	Go to the specific value when the owner controller is switched into Program mode. If you select this, enter a value from 9,999,999 . . . 99,999,999, default is 0.
Ramp to User-Defined Value	If Hold Last State - this field is disabled. User-Defined Value - check if you want the output to ramp to the user-defined value at the specified ramp rate. The ramp rate is selected from the output Limits tab. If unchecked, output signal steps to the User-Defined Value immediately on entering Program mode.

Output State in Fault Mode

These parameters are not available in Hard Run mode.

The module enters Program mode state if the Connection from Logix is inhibited. If communication later fails, all channels of the module remain in Program mode.

Select	To configure the output module to one of these
Hold Last State	Leave the output signal at its last value.
User-Defined Value	Go to a specific value if a fault occurs. If you click this button, enter a value from - 9,999,999 . . . 99,999,999, default is 0.
Ramp to User-Defined Value	If Hold Last State - This field is disabled. If User-Defined Value - You can check this if you want the output to ramp to the user-defined value at the specified ramp rate. The ramp rate is selected on the output Limits tab. If unchecked, the output signal steps to the user-defined value immediately on entering Fault mode.

The output signal goes to Fault mode when the controller faults or when communication between an output module and its controller is lost. Output State in Fault Mode appears dimmed in Hard Run mode.

Communication Failure

If communication fails while in Run mode, the output signal goes to its Fault Mode state. If communication fails while in Program mode, the output signal behaves as follows.

Select	To
Leave outputs in Program mode state	Leave output signal at the configured Program mode value
Change output to Fault mode state	Change output signal at configured Fault mode value if a communication fails (connection from controller breaks)

Limits Tab - 1756-OF8H and 1756-OF8IH Modules

Use this information to configure the parameters on the Limits tab.

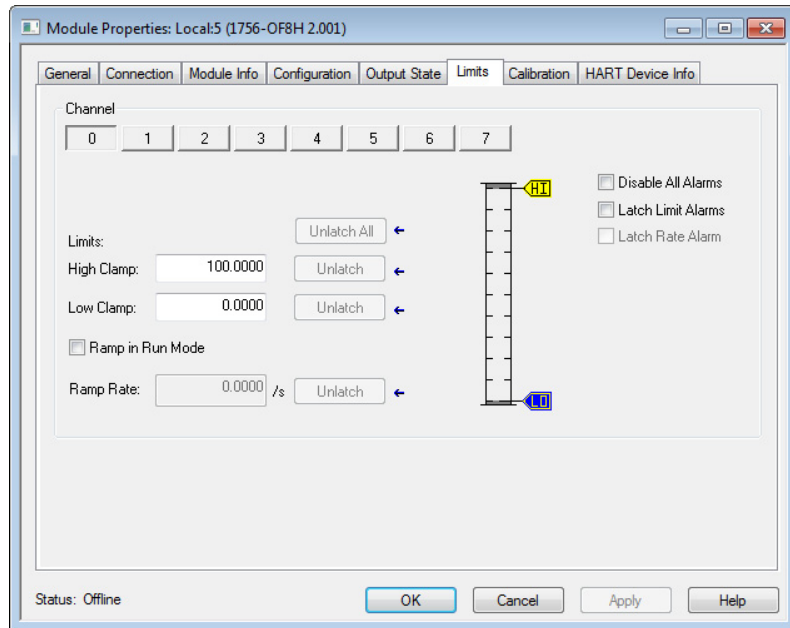

With an individual channel button selected, use these parameter descriptions to configure the alarms.

Table 86 - Alarm Tab Parameters

Parameter	Action	Notes	Available in Hard Run Mode?
Limits	Enter values or drag the corresponding flags on the slider bar to set the values.	<ul style="list-style-type: none"> The High Engineering and Low Engineering parameters on the Configuration tab set the maximum and minimum values for these alarms. Clamp limits are in engineering units. To change the trigger points by whole numbers only, hold down the shift key while dragging the flag on the slider bar. See the Limit Example on page 165. 	No
High Clamp (HI)		<ul style="list-style-type: none"> The highest value an output channel can reach in the control process. -9,999,999...99,999,999, default is 100.00. 	
Low Clamp (LO)		<ul style="list-style-type: none"> The lowest value an output channel can reach in the control process. -9,999,999...99,999,999, default is 0. 	
Ramp in Run Mode	Check	<ul style="list-style-type: none"> Enables ramping in Run mode. Ramping occurs between the current output level and any new output value received. If ramping is enabled, the output can change only at the configured ramp rate limit. 	No
Ramp Rate	Enter a value from 9,999,999...999,999,999, default is 0.	<ul style="list-style-type: none"> Defines the maximum rate of change an output can make in engineering units/second. Serves as a trigger point for a Ramp Rate Limit alarm when the Ramp in Run mode is selected. Can also be used to ramp a user-defined value in Program or Fault mode. A non-editable copy of Ramp Rate is shown on the Output State tab. 	No
Unlatch All	Click	<ul style="list-style-type: none"> Unlatches all alarms. Is not available when the project is offline. 	Yes
Unlatch	Click	<ul style="list-style-type: none"> Unlatches the adjacent alarm condition. Is not available when the project is offline. 	Yes

Table 86 - Alarm Tab Parameters (continued)

Parameter	Action	Notes	Available in Hard Run Mode?
Disable All Alarms	Check	Disables all alarms for a channel.	No
Latch Limit Alarms	Check	Maintains the high and low limit alarms even after the condition ceases. The high and low limit alarm is set if the requested output is beyond the clamp limit (>High or <Low). This is useful if you want to detect a transient alarm condition and preserve its indication until the alarm is explicitly unlatched. Click Unlatch to unlatch an alarm, or send a Common Industrial Protocol (CIP) message using the MSG instruction.	No
Latch Rate Alarm	Check	When enabled, a Rate Alarm indication remains set, even when the alarm condition returns to normal. This latch lets you maintain the alarm even after the condition ceases. The alarm unlatches only with an explicit message that acknowledges the alarm.	No

Limit Example

If your output controls a valve positioner that is configured to use Percent of Stroke for engineering units, you can enter 0 as the Low Clamp and 62 for High Clamp. You enter 0 only if you do not want the valve to be over 62% open at any time for any reason. Even if a PIDE instruction calculates the valve must open more to achieve process Setpoint, the output module clamps it to 62% open.

HART Device Info Tab

The HART Device Info tab displays information about the attached HART field device that the HART module collects.

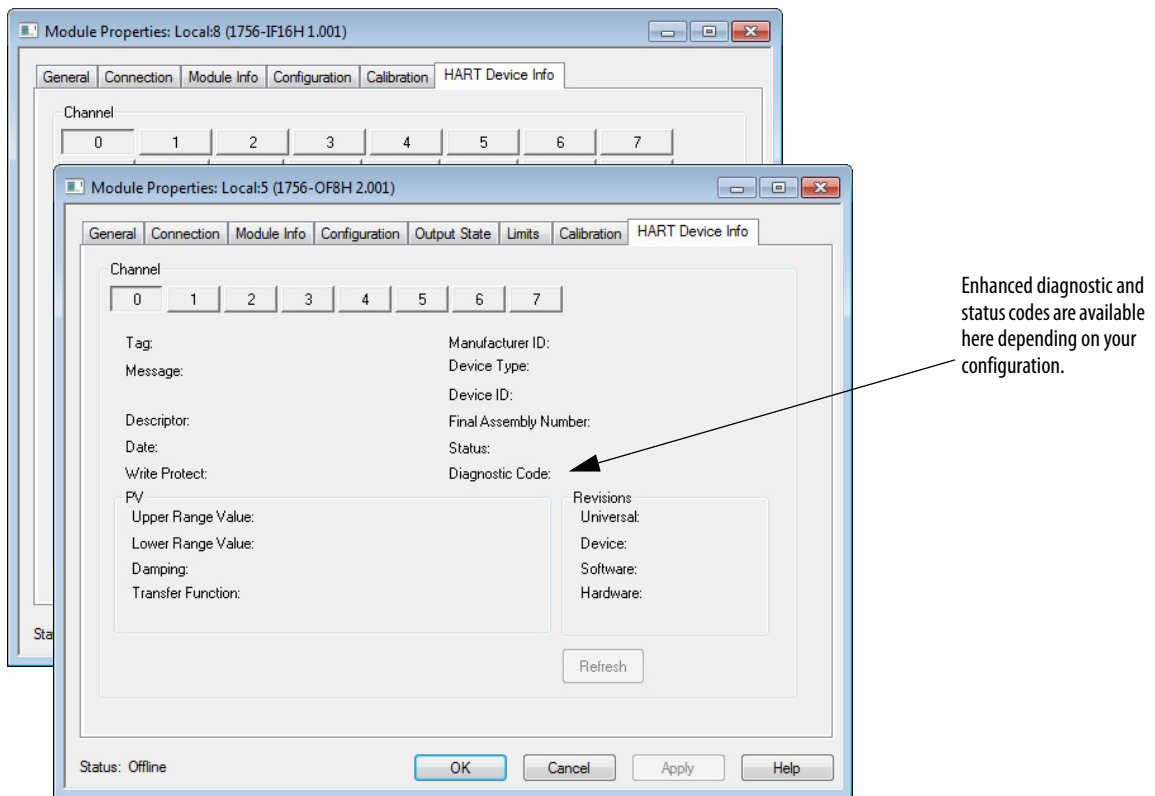

- If you selected a Listen-Only communication format when you created the module, this tab is not available.
- If HART is not enabled for this channel, Channel Not HART Enabled is displayed.

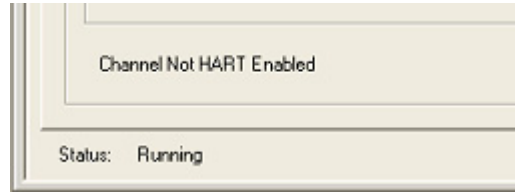

- If HART is enabled, but the HART Field Device is not responding, HART initializing is displayed.



Table 87 - HART Device Info Tab

Parameter	Description
Channel	Click a channel to display the parameters for the corresponding channel.
Refresh	Click to update all attributes that are displayed on this tab for the corresponding channel.
Tag	Displays the tag name of the HART Field Device. The tag name is entered into the Field Device to indicate its location and purpose in the plant.
Message	Displays the text that was entered in the Message parameter of the HART Field Device. The use of this parameter can vary. One possible use is to store information such as who last calibrated the device, or reference to documentation.
Descriptor	Displays the Descriptor field from the HART Field Device. The Descriptor is a text message that can be stored in the device to help identify the device or it can be used for other plant-specific purposes.
Date	Displays the date that is entered in the device. This date is often used to record the last calibration date, but it is up to the end user to maintain it. It is displayed in the format that is selected for your computer with the Regional and Language settings on the Control Panel.
Write Protect	Displays a Yes or No indicating if the HART Field Device is write protected. If a device is write protected, some parameters cannot be changed via HART communication. Sometimes devices do not indicate that the configuration has changed when their write-protect setting changes. This condition causes the previous value to remain displayed here. You can inhibit/uninhibit the HART module to refresh this value.
Manufacturer ID	Displays the manufacturer name (for example, Allen-Bradley or Endress + Hauser) or the numeric value for the manufacturer. Use the Company Identification Code table as a guide, as shown in Appendix E.
Device Type	Displays the device type for Endress + Hauser devices or a numeric value for all other manufacturer devices. Device type indicates the type of the device of the manufacturer, or product name. For example, Cerabar S pressure transmitters from Endress + Hauser have Device Type 7.
Device ID	Displays a number that represents the device ID. Device ID is a serial number that is assigned by the manufacturer that is unique among all devices that are produced by that manufacturer.
Final Assembly Number	Displays a number that represents the final assembly number. The Final Assembly Number is used for identifying the materials and electronics that comprise the field device. It is normally changed when electronics or other components are upgraded in the field. In some instances, this number references a drawing number.

Table 87 - HART Device Info Tab

Parameter	Description
Status	Channel status is available only for: <ul style="list-style-type: none"> • 1756-IF8H and 1756-OF8H firmware revision 2.001 or later • 1756-IF16H firmware revision 1.002 or later • 1756-IF16IH firmware revision 1.001 or later
Diagnostic Code	Device status is available only for: <ul style="list-style-type: none"> • 1756-IF8H and 1756-OF8H firmware revision 2.001 or later • 1756-IF16H firmware revision 1.002 or later • 1756-IF16IH firmware revision 1.001 or later
PV	In HART, the Primary Variable (PV) is signaled on the 4...20 mA analog channel. It can also be read back using HART messages. In many HART devices, the relationship between the PV and the analog signal can be adjusted. This area displays the following Process Variable attributes: <ul style="list-style-type: none"> • Upper Range Value - to use the same engineering units in your Logix controller as in the Field Device, enter this value in High Engineering on the Configuration tab. • Lower Range Value - to use the same engineering units in your Logix controller as in the Field Device, enter this value in Low Engineering on the Configuration tab. • Damping • Transfer Function - describes how the HART field device transforms the signal on its transducer to the PV. Usually Linear, but sometimes Square Root (for example, for flow), or other relationships.
Revision	Displays the following revision attributes. <ul style="list-style-type: none"> • Universal - denotes the version of the HART specification to which the device conforms. • Device • Software • Hardware

Set Device Info (1756-IF8IH and 1756-OF8IH Modules)

For the 1756-IF8IH and 1756-OF8IH modules with Configure HART Device set to Yes, a Set Device Info button appears on the HART Device Info tab. The Set Device Info button is enabled when the controller is on line and not in hard run mode. Clicking this button displays a dialog box that lets you specify tag name, message, and descriptor for the HART device on the selected channel. You can enter values in the text fields or copy existing entries that are already stored on the device. When you click the Set button, the specified values are sent to the device via HART messages.

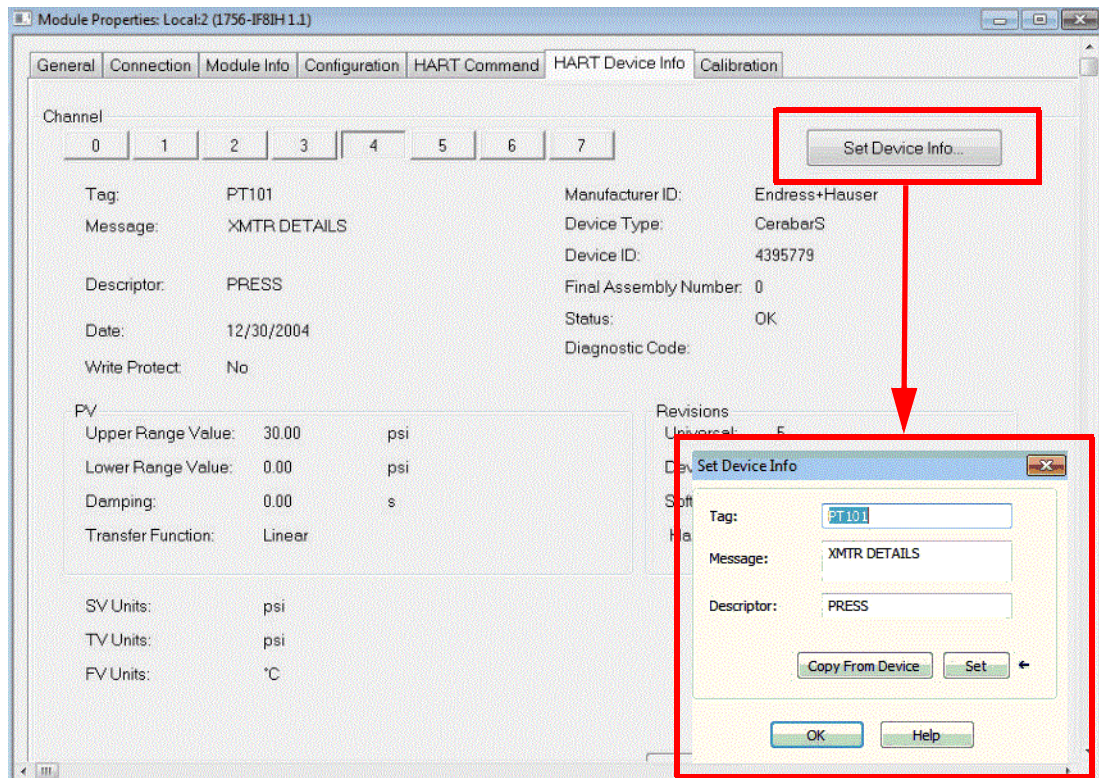

HART Command Tab - 1756-IF8IH, 1756-OF8IH

When Configure HART Device is set to Yes for the 1756-IF8IH and 1756-OF8IH modules, a HART Command tab appears in the Module Properties dialog.

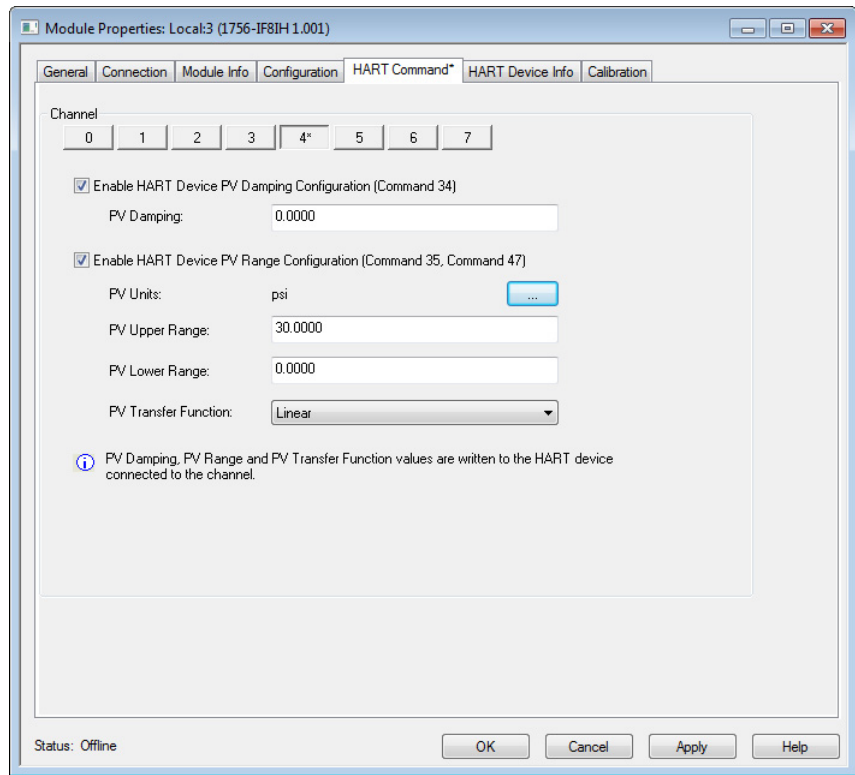

In the HART Command tab, you can specify HART device parameters for each channel. These values are sent to the HART device.

Checkbox	Parameter	Description
Enable HART Device PV Damping Configuration	PV Damping	
Enable HART Device PV Range Configuration	PV Units	Engineering units for the HART PV. Choose from the pull-down menu. See Appendix E for a list of unit codes.
	PV Upper Range	Highest value for PV in the specified engineering units.
	PV Lower Range	Lowest value for PV in the specified engineering units.
	PV Transfer Function	Form of the PV transfer function. Choose from the pull-down menu.

Calibration Tab

In the Calibration tab, you can start a module calibration and read calibration data for each channel.

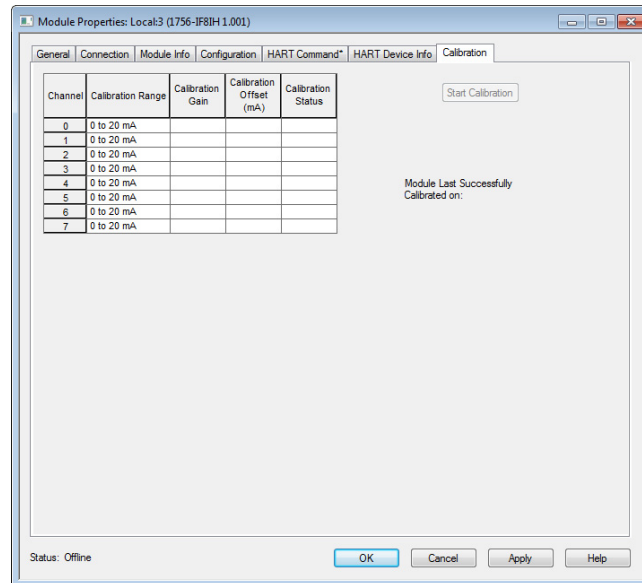

The table describes the data that is displayed on the Calibration tab.

Parameter	Description (all fields are read-only)
Calibration Range	Displays 0...20 mA for current channels or -10...10V for voltage channels, based on the output range selection on the configuration tab.
Calibration Gain	Displays the calibration gain when the module is on line.
Calibration Offset	Displays the calibration offset when the module is on line.
Calibration Status	Displays OK or Error, depending on the result of the last calibration, when the module is on line.
Last Successful Calibration	Displays the date on which a successful calibration was most recently performed.

To start calibration, either the Controller must be in “Program\Idle” mode, or the module must not be connected to a controller. When these conditions are met, clicking the Start Calibration button initiates the calibration sequence for all channels. Results of the calibration are displayed in the tab. To start a module calibration, click the Start Calibration button. The module must be offline. Calibration starts and information is exchanged via CIP messages.

Data in the Input Tags

When HART data is included in the input tag and a channel has HART enabled, the ControlLogix HART I/O module automatically collects HART data. The module also places the most common Dynamic Process Data and Device Health information directly in the input tag.

See the chapter for each module for a complete listing of the fields in the input, output, and configuration tags.

An overview of the HART data includes the following:

- HART Faults - At the beginning of the input tag included even if you click Analog Only input data tag format. These faults indicate that HART communication is not successful or that the field device is reporting a problem such as Device Malfunction, Loop Current Saturated or PV out of Limit. For example, Ch0HARTFault is set if Ch0Config.HARTEn is 0 or if no HART Field Device is attached.
- HART Device Status - A collection of status indicators that reflect the HART communication details and overall device health.
 - Init - Module is searching for a HART device.
 - Fault - HART communication is not successful. If this is 1 and Initializing is 0, probable cause is HART is not enabled on this channel.
 - Message Ready - A HART pass-through message reply is ready to be collected by using the Pass-through Query CIP message. See [Chapter 10](#) for information on how to use CIP MSGs to access HART data.
 - Current Fault - The analog current doesn't match the readback of the current received over the HART communication. An inaccurate field device, faulty wiring, or water in the conduit can cause this. Sometimes a rapid change in the signal results in a transient current fault as the analog and digital representations are sampled at slightly different times and at different places in the signal path.
 - Configuration Changed - The Field Device configuration has changed and new Field Device configuration information can be obtained from the module via CIP MSG GetDeviceInfo, which clears this bit.
 - ResponseCode - HART Communication Status or Response Code. 0 means success. See [Configure Modules in the Logix Designer Application](#) for details.
 - FieldDeviceStatus - HART device health, such as PV out of range or device malfunction. See [Appendix B](#) for details.
 - UpdatedStatusReady - indicates new device diagnostic information is available, which can be obtained by sending a CIP Message with Service 4C.

HART Dynamic Variables

Most HART devices can measure several different process characteristics or of deriving other measurements from directly sensed measurements. For example, many differential pressure transmitters can also sense the process temperature and can calculate the flow. These sensors can also calculate the volume in a tank based on a measurement of its head pressure and knowledge of tank geometry and product density.

The most important of these direct or derived measurements is assigned to the PV (Primary Variable) and the analog signal represents its value. Additional measurements can be read from the HART field device over the HART communication protocol. HART provides a standard message for reading four of the dynamic variables, called PV, SV, TV, and FV (sometimes called QV). These four dynamic variables are the four measurements of interest to a controller.

These four dynamic variables - PV, SV, TV, and FV - are automatically collected from the HART field device and placed in the input tag of the module in HART.ChxPV (for Analog and HART PV data format) or Chxx.PV (for Analog and HART by Channel data format). In some HART devices, the choice of which of the available measurements to assign to PV, SV, TV, and FV can be changed via configuration. In other more simple devices, the assignment is done at the factory and cannot be changed.

An example for a Flow Meter can be:

- PV - Primary Variable. Flow Rate in Liters per Minute.
- SV - Secondary Variable. Process Temperature in °C.
- TV - Third or Tertiary Variable. Product Density in Grams per Cubic Centimeter.
- FV - Fourth or Quaternary Variable

An example for a Valve Positioner can be:

- PV - Primary Variable. Commanded position in %.
- SV - Secondary Variable. Actual position in %.
- TV - Third or Tertiary Variable. Air Pressure in PSI.
- FV - Fourth or Quaternary Variable. Loop current in mA.

In addition to the measurement value, HART devices can provide status information that indicates the quality of the measurement.

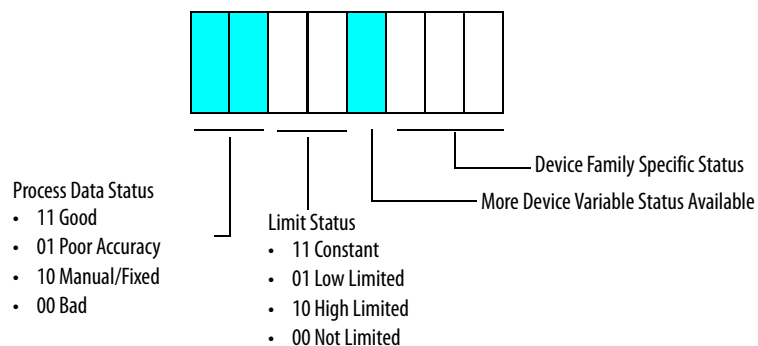

For example, if a valve positioner cannot open any further, it can set its HART.ChxSVStatus to 2#11100000. This configuration indicates that the actual position value in the SV is Good (accurately measured) but is the subject of a High Limit. This status information can be used for windup control in PID loops and for other diagnostic purposes.

The module collects the PV, SV, TV, and FV data as described in [Table 88](#).

Table 88 - Dynamic Variable Assignment⁽¹⁾

HART Version	HART Device Reports PV, SV, TV, FV Assignments in Command 50	HART Command Used by 1756 Module to Collect PV, SV, TV, FV	Device Variable Codes Used in Command 9 for PV, SV, TV, FV
5	–	3	–
6	No	3	–
	Yes	9	As Reported in Command 50
7 or later	No	9	246, 247, 248, 249
	Yes		As Reported in Command 50

(1) Table does not apply to the 1756-IF8H and 1756-OF8H modules, version 1.x, and the 1756-IF16H and 1756-OF16H modules, version 1.1

Command 3 does not provide PVStatus, SVStatus, TVStatus, or FVStatus. HART devices that indicate Command 3 as shown in [Table 88](#) have their Dynamic Variable Status values reported based on the communication status with the HART field device. If the Dynamic Variables are being collected without communication error, the Status value is 16#C0 (2#11000000), which means good. Otherwise, it is 0, meaning bad.

Some devices do not have four dynamic variables. In this case, they can report a NaN value to indicate that they have no valid value for that parameter.

The dynamic variables do not update as fast as the analog signal. The actual rate depends on the number of channels that are configured for HART (for the 8-channel modules), the number of pass-through message commands, the presence of handheld communicators or other secondary masters, and the response speed of the field device.

When eight channels are in use on the non-isolated 8-channel modules, the HART update rate is in the **10-second range**.

IMPORTANT Verify that the actual HART update rate is appropriate for your application. Remember that pass-through message traffic, additional status information, secondary masters, and communication errors can delay the update rate. On the non-isolated 8-channel modules, because all channels share the HART modem, increased delay on one channel affects other channels also.

IMPORTANT Verify that HART data is valid by checking ChxFault, HARTFault, and values such as PVStatus and SVStatus.

How the Module Automatically Collects Data

The ControlLogix HART analog module automatically sends HART messages to characterize the HART field device and collect the dynamic variables. It also collects additional status information when the device indicates it is available. When the device indicates that its configuration has changed, HART messages are sent to reread the configuration information so that a current copy is cached in the modules.

The diagrams on [page 175](#) and [page 176](#) show the general flow of the start-up characterization, response to a new configuration, and cyclic scanning of dynamic variables. Not shown are periodic checks of the current and reading the additional status information.

In addition to the HART activities outlined in the diagram, if there are HART pass-through messages to send, they are interleaved in the auto scanning. Logix controllers can send pass-through messages by using CIP MSG instructions, and Asset Management systems can send them. See [Chapter 10](#) for more information.

HART messages are sent on only one channel at a time when you are using the 1756-IF8H or 1756-OF8H module. When you are using the 1756-IF8IH, 1756-OF8IH, 1756-IF16H, or 1756-IF16IH module, messages are sent on all channels simultaneously.

If the HART field device configuration is changed—from a handheld, asset management, or device faceplate—cyclic reading of the Dynamic Variables pauses briefly while the configuration changes are assimilated. The HART.ChxDeviceStatus.ConfigurationChanged status is set when the updated configuration is retrieved from the HART field device and stored in the module to indicate that new data is available for GetDeviceInfo CIP MSG.

See [Use a CIP MSG to get HART Data on page 177](#) for more information, and specifically [page 189](#) for HART pass-through schedule choices.

Figure 32 - 1756-IF8H and 1756-OF8H Flowchart

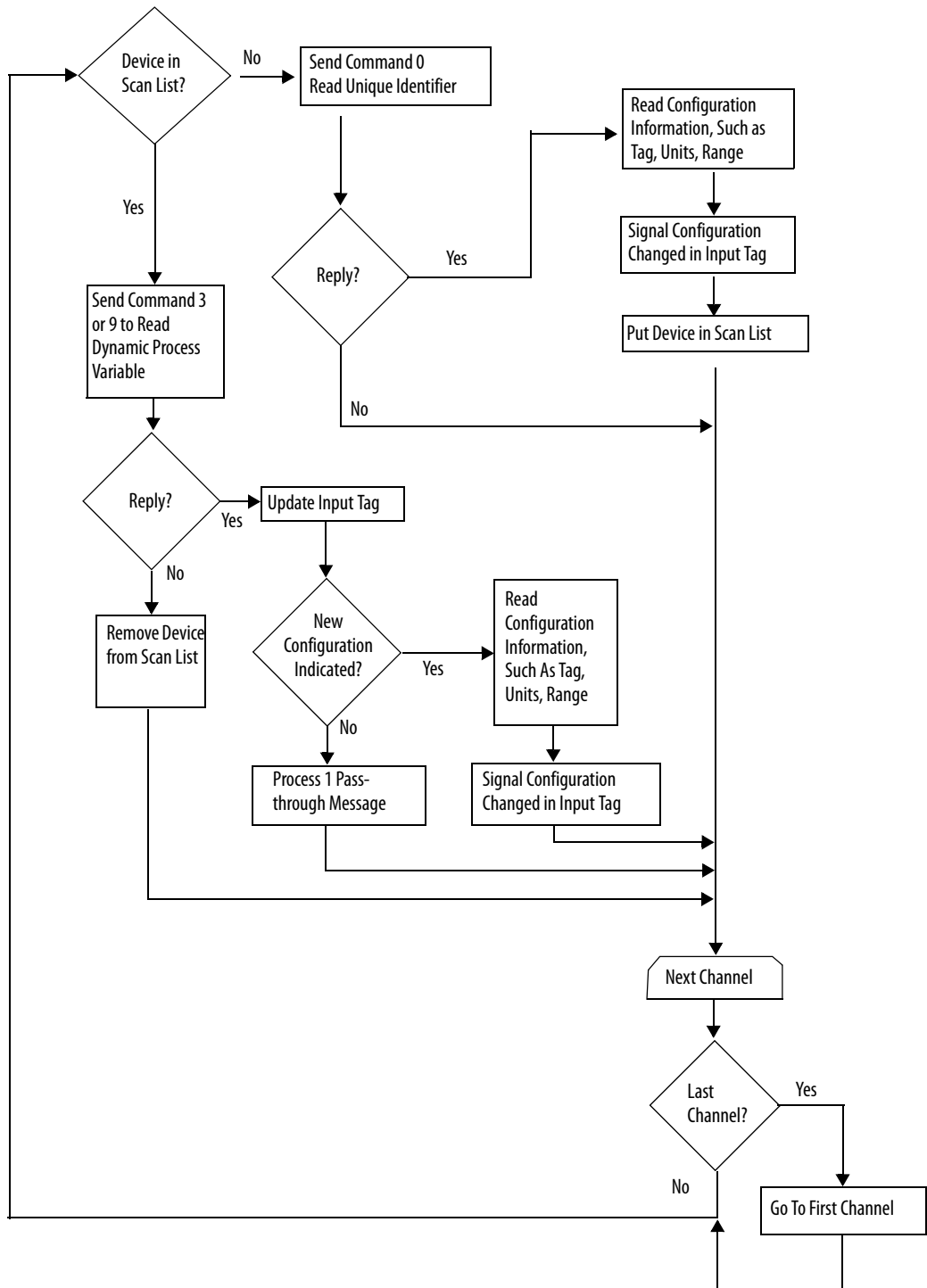
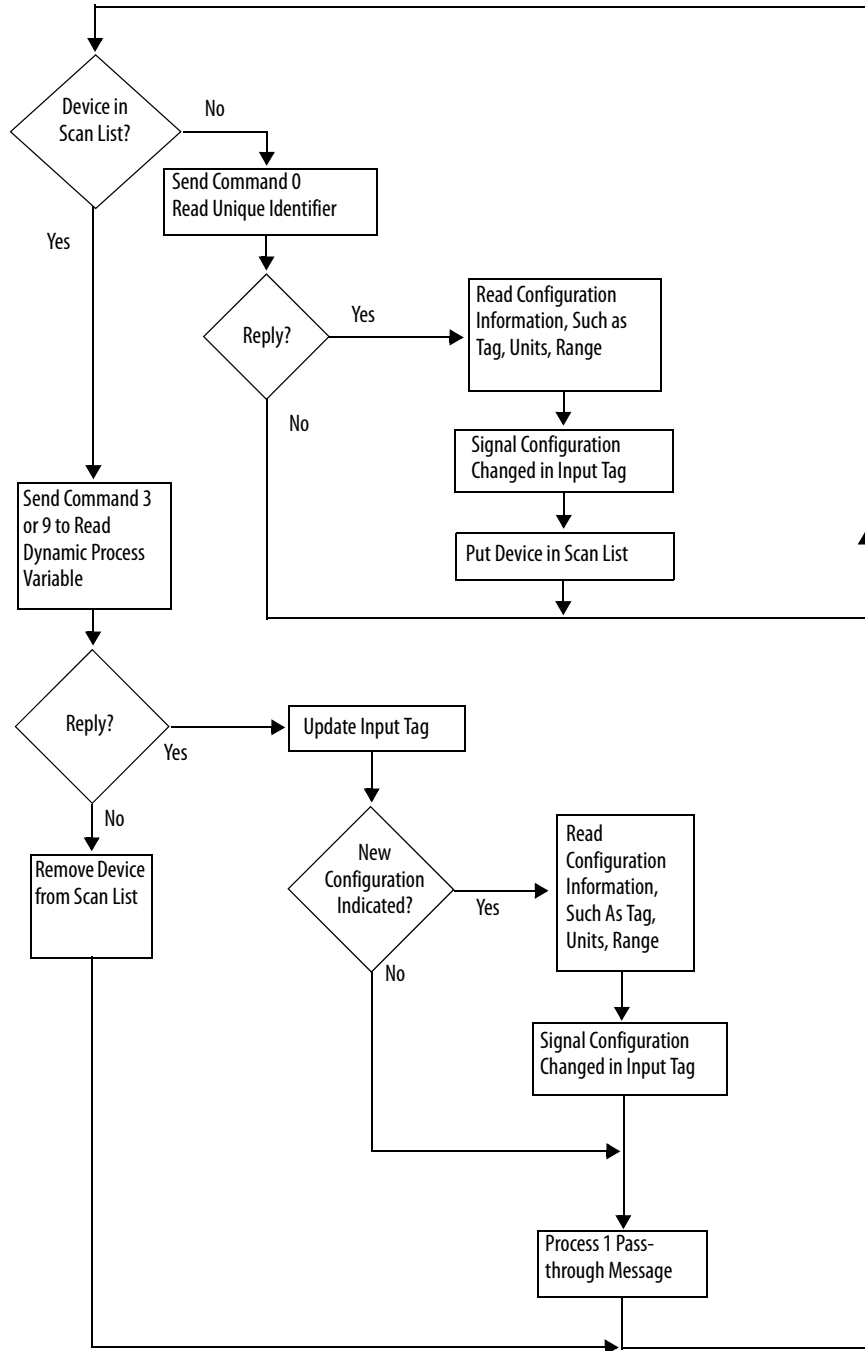

Figure 33 - 1756-IF8IH, 1756-OF8IH, 1756-IF16H, and 1756-IF16IH Modules Flowchart



Use a CIP MSG to get HART Data

This chapter discusses these topics.

Topic	Page
Use MSG Instructions to Access the HART Object	178
CIP Services to Access Common HART Data	179
Use a CIP Generic MSG to get HART Device Information	184
CIP Services to Pass-through a HART Message to the HART Field Device	187
HART Module Scanning Diagram with Pass-through Messages	189
HART Pass-through CIP Message Layout Details	191
HART Pass-through Message Ladder Logic Example	194

This chapter shows how to use HART data in your Logix controller via MSG instructions. Examples of reasons to do this include the following:

- You need only occasional access to the data, and do not want to use the extra network capacity and memory that is required for the Analog with HART PV or Analog and HART by Channel input tags.
- You need extra information, such as device tag, ranges, or manufacturer-specific information.
- You must send a manufacturer-specific command to the HART device.

Usually, everything you must use a HART instrument is automatically collected and placed in the input tag, and these CIP MSG instructions are not needed.

The 1756 ControlLogix® HART analog modules support these broad categories of MSG-based HART access:

- CIP formatted messages to retrieve common HART data cached in the module.
- CIP messages that contain HART formatted commands that are passed directly to the HART field device for processing. These messages are called pass-through messages.

By using these mechanisms your Logix controller has easy access to some commonly used data and, with some extra effort, access to any HART feature.

The features that are described in this chapter use MSG instructions. For more information and examples about MSG instructions, refer to [Chapter 12](#), which explains how to use MSG instructions to unlatch alarms or reconfigure modules.

Use MSG Instructions to Access the HART Object

The HART Object contained in the module handles both categories of MSG. There is one HART Object for each channel. Some CIP messages can be sent to the Class Instance (Instance 0) of the HART object. Most MSGs are sent to a specific instance of the HART object that is associated with a particular channel.

This table shows channel and instance correspondence.

Channel	Instance
0	1
1	2
2	3
3	4
...	...
15	16

These tables show service codes for CIP services.

Class	Service Code	Function
16#35D	16#4B	Read Dynamic Variables
	16#4C	Read Additional Status
	16#4D	Get HART Device Information

Class	Service Code	Pass-through Messages
16#35D	16#4E	Init
	16#4F	Query
	16#50	Flush Queue

TIP The 16# means that this number is Hex display style.

CIP Services to Access Common HART Data

You can get the following kinds of HART data easily from the HART object:

- HART field device information - Similar to data displayed on the Module Properties HART Device Info tab of the Studio 5000 Logix Designer® application.
- Additional status - HART devices that support extended diagnostics can indicate in their Field Device Status that some additional diagnostic information is available.
- Dynamic variables - The same PV, SV, TV, FV that is in the input tag. The mapped Device Variable Code and the engineering units are included.

The data in these commands is returned in the format that is used by Logix controllers, so it is easy to use in your control program. HART data is natively in another format, called big-endian, but the module converts the values in these messages for you.

See the tables that list the data in the CIP messages and the example of getting the Device Info.

In the following sections, the definition CMD#0 byte 3, for example, means HART command 0, byte 3. If your field device user manual includes information about HART command responses, this information is helpful to you. Consult the HART protocol specification for further information on HART commands. See [Appendix B on page 227](#) for more information.

Read Dynamic Variables (Service Code = 16#4B)

[Table 89...](#) [Table 91](#) show the request and reply packet structures for the Read Dynamic Variables service.

Table 89 - Request Packet

Offset	Field	Data Type	Definition
			No request data

Request size = 0 bytes

Table 90 - Reply Packet - Request Failed

Offset	Field	Data Type	Definition
0	Status	USINT	Command status
1	Pad		Pad byte

Reply size = 2 bytes

Request Failed

See [Appendix D on page 247](#) for an explanation of the engineering unit code numbers.

Table 91 - Reply Packet - Request Succeeded

Offset	Field	Data Type	Definition
0	Status	USINT	Command status
1	HARTCommandStatus		HART Device reply Status Byte # 1 (response code)
2	HARTFieldDeviceStatus		HART Device reply Status Byte # 2
3	HARTExtDevice Status		Status Byte returned from Cmd 9 or 0 for 5.x rev HART devices
4...7	PV	REAL	HART Primary variable
8...11	SV		HART Secondary variable
12...15	TV		HART Third variable
16...19	FV		HART Fourth variable
20	PV Units	USINT	Primary variable unit code
21	SV Units		Secondary variable unit code
22	TV Units		Third variable unit code
23	FV Units		Fourth variable unit code
24	PV Assignment Code		Primary variable assignment code
25	SV Assignment Code		Secondary variable assignment code
26	TV Assignment Code		Third variable assignment code
27	FV Assignment Code		Fourth variable assignment code
28	PV Status		1 byte status from Cmd 9(Rev 6.x) or if Rev 5.x device: 16#C0 = Connected 16#00 = Not Connected
29	SV Status		1 byte status from Cmd 9 or if Rev 5.x device: 16#C0 = Connected and Device provides this value in CMD 3 (that is, does not truncate) 16#00 = Not Connected
30	TV Status	1 byte status from Cmd 9 or if Rev 5.x device: 16#C0 = Connected and Device provides this value in CMD 3 (that is, does not truncate) 16#00 = Not Connected	
31	FV Status	1 byte status from Cmd 9 or if Rev 5.x device: 16#C0 = Connected and Device provides this value in CMD 3 (that is, does not truncate) 16#00 = Not Connected	
32...35	Loop Current	REAL	Device reported digital loop current value. (Value from Cmd 3 for Rev 5.x devices or Cmd 2 if Rev 6.x device)

Reply Size = 36 bytes

Read Additional Status (Service Code = 16#4C)

[Table 92](#)...[Table 94](#) show the request and reply packet structures for the Read Additional Status service. Reply Size = 2...224 bytes.

Table 92 - Request Packet

Offset	Field	Data Type	Definition
			No request data
Request size = 0 bytes			

Table 93 - Reply Packet - Request Failed

Offset	Field	Data Type	Definition
0	Status	USINT	Command status
1	Pad		Pad byte
Reply size = 2 bytes			
Request Failed			

Table 94 - Reply Packet - Request Succeeded

Offset	Offset	Data Type	Definition
0	Status	USINT	Command status
1	Count		Number of Ext Status bytes available
2...26	Ext Status Bytes		Extended Status bytes returned by CMD48
7	Pad		Pad type

Reply Size = Instance 1...8: 2...28 bytes; Instance 0: 224 bytes. If sent to Instance 0, all channels of the module are included in the response, which results in 28 bytes per channel. This total is due to 27 bytes of response to the HART Read Additional Status plus 1 byte of pad to align the data to a 32-bit boundary.

Get Device Information (Service Code 16#4D)

[Table 95](#)...[Table 97](#) show the request and reply packet structures for the Get Device Information service.

Table 95 - Request Packet

Offset	Field	Data Type	Definition
			No request data

Request size = 0 bytes

Table 96 - Reply Packet - Request Failed

Offset	Field	Data Type	Definition
0	Status	USINT	Command status
1	Pad		Pad byte

Reply size = 2 bytes

Table 97 - Reply Packet - Request Succeeded

Offset	Field	Data Type	Definition ⁽¹⁾
0	Status	SINT	Command status
1	Manufacturer ID		CMD#0, Byte 1 If this byte is $\geq 16\#E0$, refer to byte offset 10 and 11 for the extended manufacturer identification.
2	Device Type		CMD#0, Byte 2
3	Preamble		CMD#0, Byte 3
4	Universal Command Code		CMD#0, Byte 4
5	Transducer Spec Code		CMD#0, Byte 5
6	Software Revision		CMD#0, Byte 6
7	Hardware Revision		CMD#0, Byte 7
8	Flags		CMD#0, Byte 8
9	Pad_1 for 16-bit alignment		
10...11	Extended Manufacturer ID		CMD#0, Byte 1 if HART revision is < 7 CMD#0, Bytes 17...18 if HART revision is ≥ 7
12...15	Device ID Number	DINT	CMD#0, Bytes 9...11
16...27	Tag	HARTTag	CMD#13, Bytes 0...5 See HARTTag on page 186 for more information.
28...47	Descriptor	HARTDescriptor	CMD#13, Bytes 6...17 See HARTDescriptor on page 186 for more information.
48	DateDay	SINT	CMD#13, Byte 18
49	DateMonth		CMD#13, Byte 19
50...51	DateYear	INT	CMD#13, Byte 20 (+ 1900)
52...55	Final AssemblyNumber	DINT	CMD#16, Bytes 0...2

Table 97 - Reply Packet - Request Succeeded

Offset	Field	Data Type	Definition ⁽¹⁾
56...91	Message	HARTMsg	CMD#12, Bytes 0...23 See HARTMsg on page 186 for more information.
92	PVCode	SINT	CMD#50, Bytes 0, 16#ff if not supported
93	SVCode		CMD#50, Bytes 1, 16#ff if not supported
94	TVCode		CMD#50, Bytes 2, 16#ff if not supported
95	FVCode		CMD#50, Bytes 3, 16#ff if not supported
96	PVUnits		CMD#3, Byte 4
97	SVUnits		CMD#3, Byte 9, 0 if not present
98	TVUnits		CMD#3, Byte 14, 0 if not present
99	FVUnits		CMD#3, Byte 19, 0 if not present
100	TransferFunction		CMD#15, Byte 1
101	RangeUnits		CMD#15, Byte 2
102...103	Expanded Device Type Code		
104...107	PVLowerRange	REAL	CMD#15, Bytes 3...6
108...111	PVUpperRange		CMD#15, Bytes 7...10
112...115	DampingValue		CMD#15, Bytes 11...14
116	WriteProtectCode	SINT	CMD#15, Byte 15
117	Pad_8 for 32-bit alignment		
118...119	Private Label Manufacturer 16 bit		CMD#0, Byte 2 if HART revision is < 7 CMD#0, Bytes 19...20 if HART revision is ≥ 7

Reply Size = 120 bytes

(1) See [Appendix B on page 227](#) for related information.

Use a CIP Generic MSG to get HART Device Information

For an example, this rung of ladder logic retrieves fresh HART device information whenever the 1756-IF8H, 1756-IF8IH, 1756-OF8H, or 1756-OF8IH module indicates that new configuration is available.

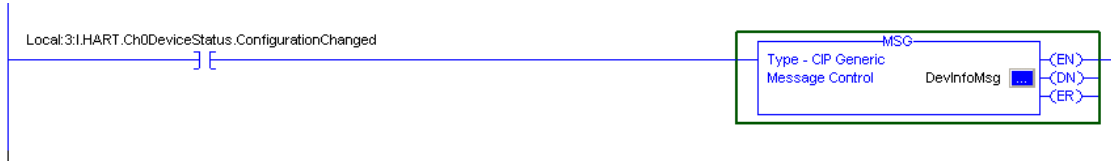

If the Device Information is critical to your application, be sure to check for .ER errors and implement a recovery strategy.

This figure is the Message Configuration dialog box.

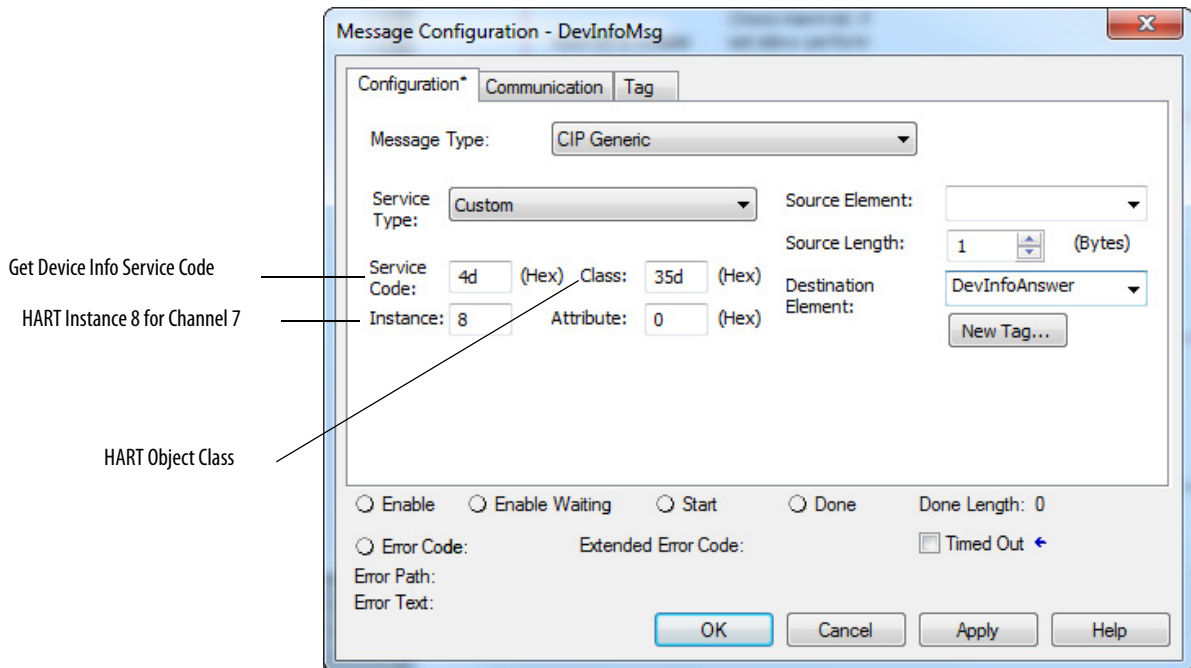

The device information for the HART Device on channel 7 is read and put in DevInfoAnswer.

The Destination tag is as shown in the Controller Tags dialog box.

Name	Value	Force M	Style	Data Type
[-] DevInfoAnswer	{...}	{...}		HARTGetDeviceInfo
+ DevInfoAnswer.Status	0		Decimal	SINT
+ DevInfoAnswer.Manufacturer	17		Decimal	SINT
+ DevInfoAnswer.DeviceType	24		Decimal	SINT
+ DevInfoAnswer.Preamble	3		Decimal	SINT
+ DevInfoAnswer.UniversalCommandCode	5		Decimal	SINT
+ DevInfoAnswer.TransducerSpecRev	20		Decimal	SINT
+ DevInfoAnswer.SoftwareRev	50		Decimal	SINT
+ DevInfoAnswer.HardwareRev	80		Decimal	SINT
+ DevInfoAnswer.Flags	0		Decimal	SINT
+ DevInfoAnswer.pad1	0		Decimal	SINT
+ DevInfoAnswer.pad2	0		Decimal	SINT
+ DevInfoAnswer.pad3	0		Decimal	SINT
+ DevInfoAnswer.DeviceID	3738141		Decimal	DINT
+ DevInfoAnswer.Tag	'PT101'	{...}		HARTTag
+ DevInfoAnswer.Descriptor	'E+H CERABAR S'	{...}		HARTDescriptor
+ DevInfoAnswer.DateDay	11		Decimal	SINT
+ DevInfoAnswer.DateMonth	6		Decimal	SINT
+ DevInfoAnswer.DateYear	2006		Decimal	INT
+ DevInfoAnswer.FinalAssemblyNumber	0		Decimal	DINT
+ DevInfoAnswer.Message	'DESCRIPTIVE DEV...'	{...}		HARTMsg
+ DevInfoAnswer.PVCode	0		Decimal	SINT
+ DevInfoAnswer.SVCode	1		Decimal	SINT
+ DevInfoAnswer.TVCode	2		Decimal	SINT
+ DevInfoAnswer.FVCode	3		Decimal	SINT
+ DevInfoAnswer.PVUnits	8		Decimal	SINT
+ DevInfoAnswer.SVUnits	8		Decimal	SINT
+ DevInfoAnswer.TVUnits	8		Decimal	SINT
+ DevInfoAnswer.FVUnits	32		Decimal	SINT
+ DevInfoAnswer.TransferFunction	0		Decimal	SINT
+ DevInfoAnswer.RangeUnits	8		Decimal	SINT
+ DevInfoAnswer.pad6	0		Decimal	SINT
+ DevInfoAnswer.pad7	0		Decimal	SINT
DevInfoAnswer.PVLowerRange	0.0		Float	REAL
DevInfoAnswer.PVUpperRange	100.0		Float	REAL
DevInfoAnswer.DampingValue	2.0		Float	REAL
+ DevInfoAnswer.WriteProtectCode	0		Decimal	SINT
+ DevInfoAnswer.pad8	0		Decimal	SINT
+ DevInfoAnswer.pad9	0		Decimal	SINT
+ DevInfoAnswer.pad10	0		Decimal	SINT
+ DevInfoMsg	{...}	{...}		MESSAGE

The following figure shows string types for HARTTag, HARTDescriptor, and HARTMsg.

HARTTag

String: HARTTag

Name: HARTTag

Description:

Maximum Characters: 8

Members: Data Type Size:

Name	Data Type	Style	Description
LEN	DINT	Decimal	
DATA	SINT[8]	ASCII	

HARTDescriptor

String: HARTDescriptor

Name: HARTDescriptor

Description:

Maximum Characters: 16

Members: Data Type Size:

Name	Data Type	Style	Description
LEN	DINT	Decimal	
DATA	SINT[16]	ASCII	

HARTMsg

String: HARTMsg

Name: HARTMsg

Description:

Maximum Characters: 32

Members: Data Type Size:

Name	Data Type	Style	Description
LEN	DINT	Decimal	
DATA	SINT[32]	ASCII	

CIP Services to Pass-through a HART Message to the HART Field Device

The HART object supports these CIP messages for HART pass-through messaging: Pass-through Init, Pass-through Query, Flush Queue (rarely needed).

With these three CIP messages, your Logix controller can format the individual bytes of a HART command, send it to a HART field device, and retrieve the response in HART format.

Native HART data is in another format than used by Logix controllers. HART uses the big-endian format and Logix uses little-endian format. This means the order of the bytes in a number is in the opposite order so they must be reversed before use. Logix little-endian means that the least significant byte of a number is stored at the lowest address (array index).

Logix also aligns data on boundaries that permit fast access and HART packs them into the smallest space. HART encodes text strings using 6 bits per letter into a format called Packed ASCII. When using pass-through messaging, your Logix program must be aware of these data layout issues.

The pass-through message CIP services that are supported by the HART object are simplified. The module provides the 5-byte address required by HART messages and the Checksum is calculated automatically for you.

Follow these steps to send a HART pass-through message.

1. Send a CIP message to tell the 1756-IF8H, 1756-IF8IH, 1756-OF8H, or 1756-OF8IH module to send a message to a HART field device (Init).
2. Send a CIP message to retrieve the HART Reply from the 1756-IF8H, 1756-IF8IH, 1756-OF8H, or 1756-OF8IH module (Query).

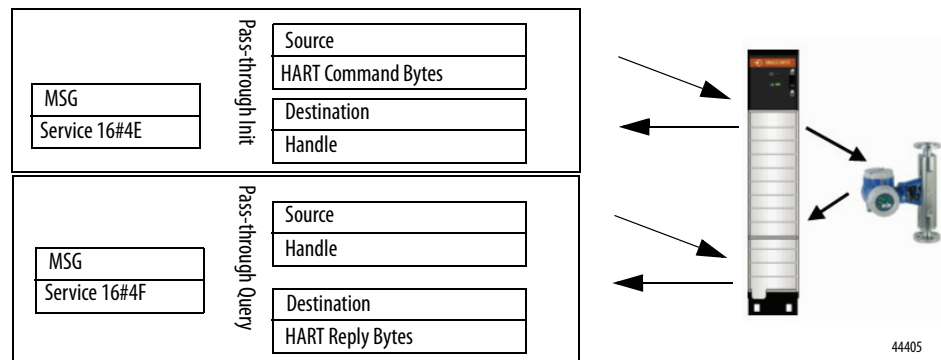

If your input tag includes the HART PV data, a status indicator `HART.ChxDeviceStatus.MsgReady` tells your program that a HART reply is ready to retrieve with the Pass-through Query command.

The CIP reply from the Init service includes a number that is called the handle. This handle identifies the HART message that was placed in a queue for transmission to the field device. When the reply is received and `MsgReady` is set to 1, your Logix controller sends a Query containing that same handle to retrieve the HART reply. The reason these steps are necessary is that it can take a long time for the HART command to be transmitted and a reply received. If all eight channels are in use, the time for a reply would be about 10 seconds if there was no other pass-through traffic.

HART Module Scanning Diagram with Pass-through Messages

When HART pass-through messages are being sent, the normal data acquisition sequence is modified as shown in the diagram. In this case, the Pass-through is configured to send one pass-through message for each channel scanned.

It can be configured for lower priority on the Configuration tab of the Module Properties dialog box.

Figure 34 - 1756-IF8H and 1756-OF8H Flowchart.

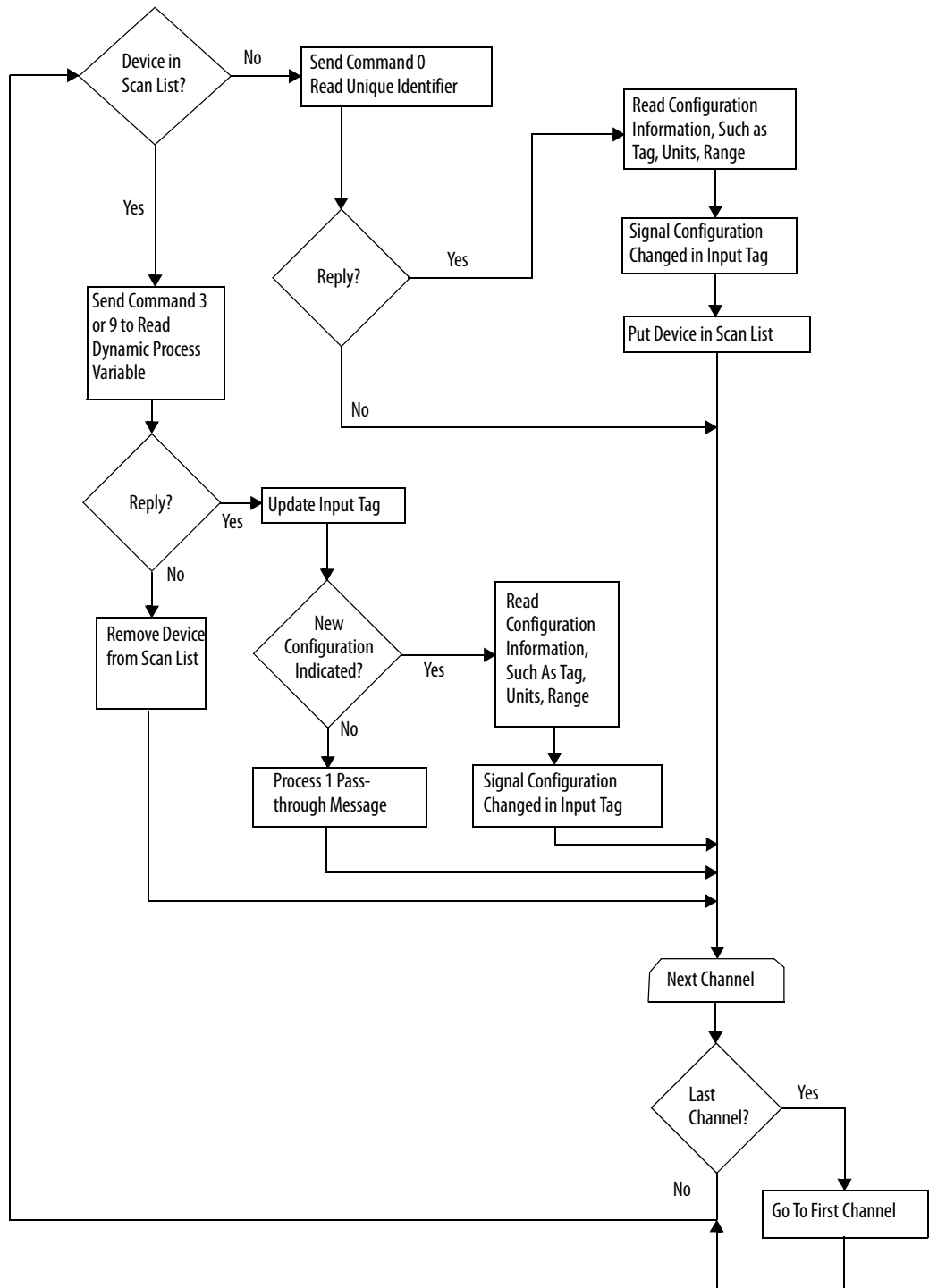
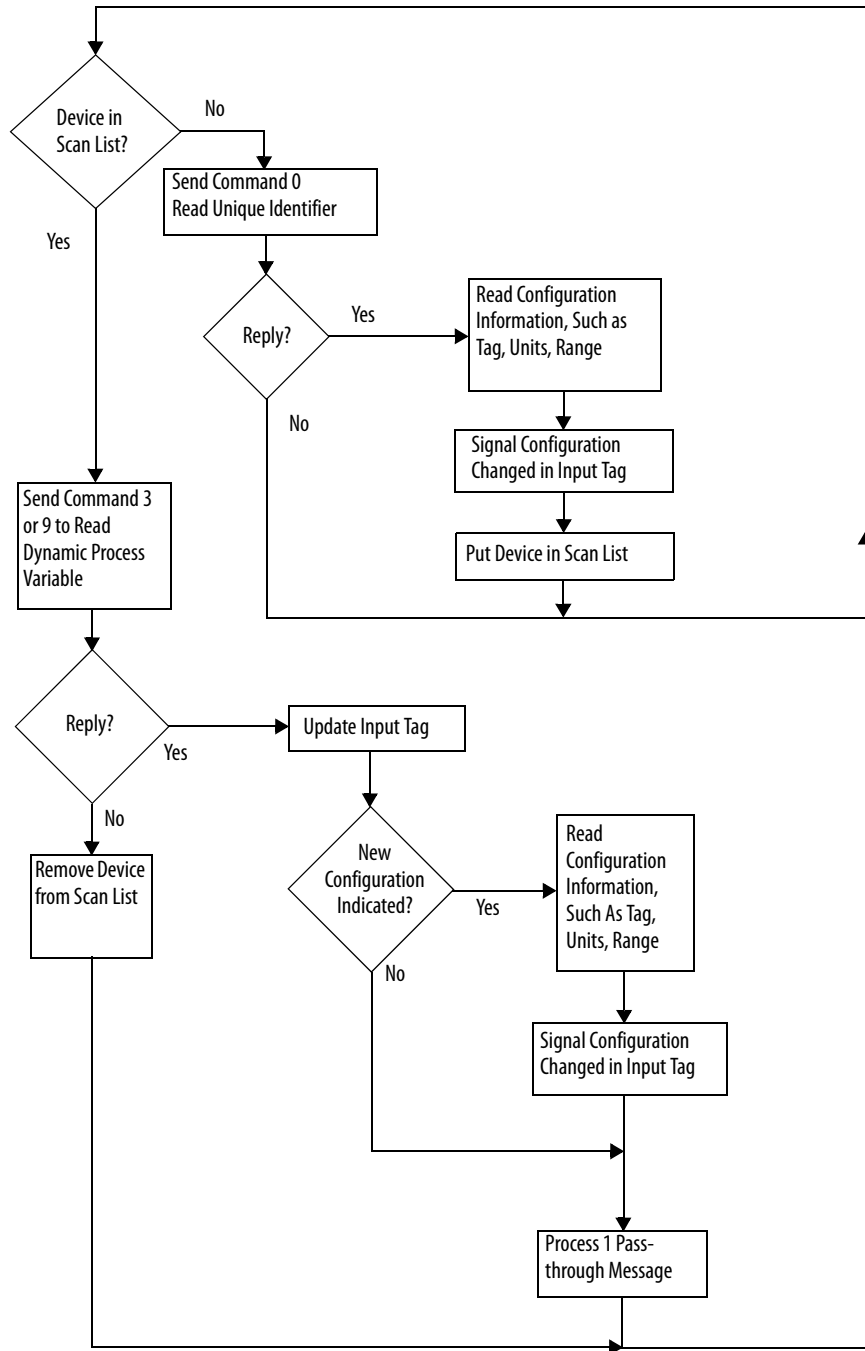

Figure 35 - 1756-IF8IH, 1756-OF8IH, 1756-IF16H, and 1756-IF16IH Modules Flowchart



HART Pass-through CIP Message Layout Details

See the tables in this section for pass-through information.

Pass-through Init (Service Code 16#4E)

[Table 98](#)...[Table 101](#) show the request and reply packet structures for the Pass-through Init service.

Table 98 - Short Format (Ladder) Request Packet (service code 16#4E)

Offset	Field	Data Type	Definition
0	HART Command	USINT	HART Command Number ^{(1) (2)}
1	HART Data Size	USINT	Number of Data Bytes for Selected HART Command ⁽¹⁾⁽²⁾
2...256	HART Data bytes	As many bytes as in HART Data Size	HART Command Data ⁽¹⁾

Request Size = 2...257 bytes

(1) See [Appendix B on page 227](#) for more information.

(2) If this field is displayed as SINT in Logix Designer application, values > 127 appear negative.

Table 99 - Long Format (Logix) Request Packet (service code 16#5B, 16#5F)

Offset	Field	Data Type	Definition
0	Start or Delimiter		
1...5	Long Form Address		Number of Data Bytes for Selected HART Command ⁽¹⁾⁽²⁾
6	HART Command	USINT	HART Command Number ^{(1) (2)}
7	Request Data Count		
2...256	HART Data bytes	As many bytes as in HART Data Size	HART Command Data ⁽¹⁾

Request Size = 2...257 bytes

(1) See [Appendix B on page 227](#) for more information.

(2) If this field is displayed as SINT in Logix Designer application, values > 127 appear negative.

Table 100 - Short Format (Ladder) Reply Packet

Offset	Field	Data Type	Definition
0	Status	USINT	Command status 32 = Busy (queues full) - try again later 33 = Initiated - command started - send Query to get the reply 35 = Dead - Device not online
1	HART Command	USINT	Echo of HART Command number ⁽¹⁾
2	Handle	USINT	Handle Used in Query Operation ⁽¹⁾
3	Queue space remaining	USINT	Number of queues still Available for This Channel ⁽¹⁾ If status (bit 0) is 35, refer to Table 104 for the error code description.

Reply Size = 4 bytes

(1) If this field is displayed as SINT in Logix Designer application; values > 127 appear negative.

Table 101 - Long Format (Logix) Reply Packet

Offset	Field	Data Type	Definition
0	Status	USINT	Command status 32 = Busy (queues full) - try again later 33 = Initiated - command started - send Query to get the reply 35 = Dead - Device not online
1	HART Command	USINT	Echo of HART Command number ⁽¹⁾
2	Handle	USINT	Handle Used in Query Operation ⁽¹⁾
3	Queue Number or Reason Code	USINT	The queue number in which the request was placed
4	Queue space remaining	USINT	Number of queues still Available for This Channel ⁽¹⁾
5	Device Data Changed Flag	BOOL (one byte, 0 or 1)	Signals that the "Device Information " data has changed
Reply Size = 4 bytes			

(1) If this field is displayed as SINT in Logix Designer application, values > 127 appear negative.

Pass-through Query (Service Code 16#4F)

[Table 102](#) and [Table 103](#) show the request and reply packet structures for the Pass-through Query service.

Table 102 - Request Packet

Offset	Field	Data Type	Definition
0	Handle	USINT	Handle for Query (from Handle Field above) ⁽¹⁾
Request Size = 1 byte			

(1) If this field is displayed as SINT in Logix Designer application, values > 127 appear negative.

Table 103 - Reply Packet

Offset	Offset	Data Type	Definition
0	Status	USINT	Query Status 00 = Success 34 = Running - try again later 35 = Dead (See MsgReady in Input Tag)
1	HART Command	USINT	Echo of HART Command ⁽¹⁾
2	HART CommStatus	USINT	HART Reply Status Byte #1 (response code) ⁽¹⁾
3	HART FieldDeviceStatus	USINT	HART Reply Status Byte #2 ⁽¹⁾ If status (bit 0) is 35, refer to Table 104 for the error code description.
4	Data Size	USINT	Number of Data Bytes in Reply for HART Command ⁽¹⁾
5...259	HART Reply Data ...	USINT	Data Bytes Returned in Data Field of HART Reply to Requested Command ⁽¹⁾
Reply Size = 6...260 bytes			

(1) If this field is displayed as SINT in Logix Designer application, values > 127 appear negative.

Pass-through Error Codes

[Table 104](#) defines the error codes that are received when the pass-through status (bit 0) is Dead (35).

Table 104 - Pass-through Error Codes

Value	Definition	Notes
16#81	No response from HART device	
16#82	Invalid long frame address	Applies to only FULL-HART format
16#83	Invalid HART message checksum	Applies to only FULL-HART format
16#84	HART Command not allowed (blocked by module)	Applies to only Ladder Pass-through
16#85	Invalid channel selected	N/A for 1756-IF16H and 1756-IF16IH modules
16#86	Channel is not HART Enabled	
16#87	Channel does not have a device connected	Module has not established HART communication on this channel
16#89	Size of CIP message too small to hold size of HART message	Module reviews HART data size field in request and validates that the incoming CIP message size is large enough to send all data
16#8A	Invalid handle	Applies to only Query message
16#8B	Invalid start delimiter	Applies to only FULL-HART format

TIP The 16# means that this number is Hex display style.

Flush Queue (Service Code= 16#50)

[Table 105](#) and [Table 106](#) show the request and reply packet structures for the Flush Queue service.

Table 105 - Request Packet

Offset	Field	Data Type	Definition
			No request data

Request size = 0 bytes

Table 106 - Reply Packet

Offset	Field	Data Type	Definition

Flush Queue can be sent to have the 1756-IF8H, 1756-IF8IH, 1756-OF8H, or 1756-OF8IH module discard any pending HART replies awaiting a query command. These replies are automatically discarded after a period, which is configurable on the Configuration tab of the Module Properties dialog box. This value is usually 15 seconds. Unless you must discard the replies faster than 15 seconds, you do not need to use this Flush Queue command.

HART Pass-through Message Ladder Logic Example

This is an example of sending HART command 9, which reads Device Variables from the HART field device. You send a list of the Device Variable codes you want, and the field device responds with its values, units, classification, and status.

The information in HART command 9 can be obtained more easily by using service 4B, but this example gives you an idea of how to send any pass-through message command you want.

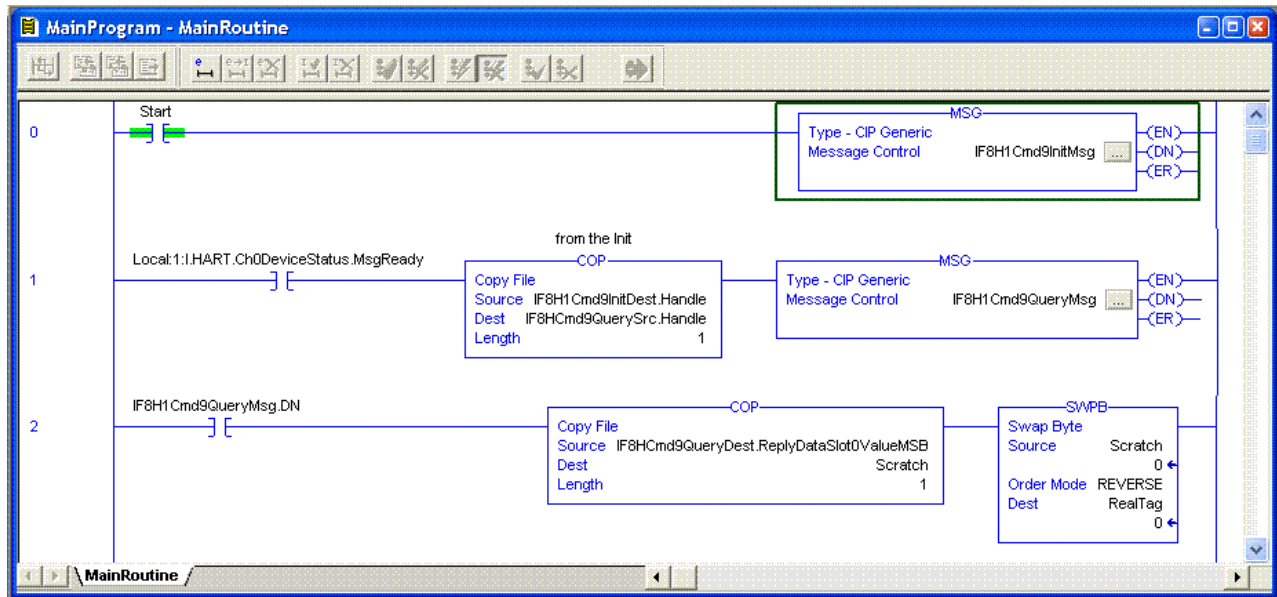

SWPB reverses the order of bytes in the PV, SV, TV, FV floating point numbers to be in the Logix REAL format.

The following dialog boxes are the Init Message Configuration and Communication tabs when Command 9 is sent to HART device on channel 0. Note instance 1 means Channel 0.

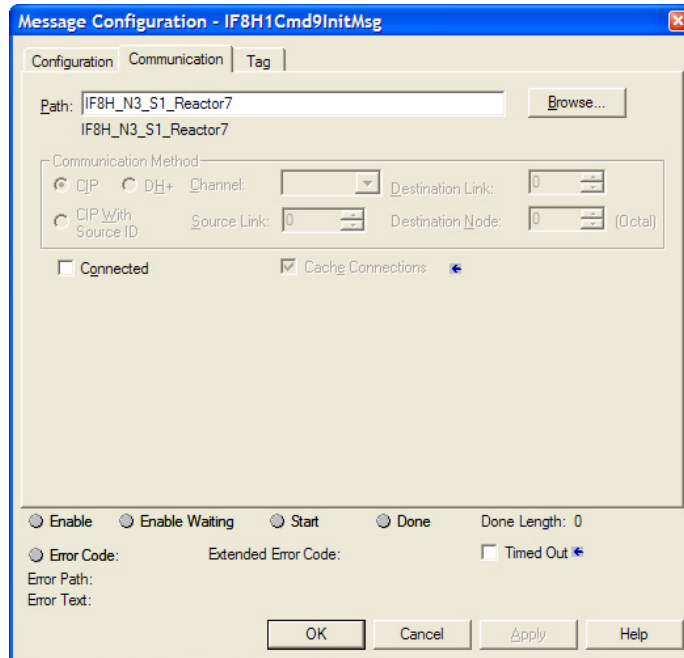
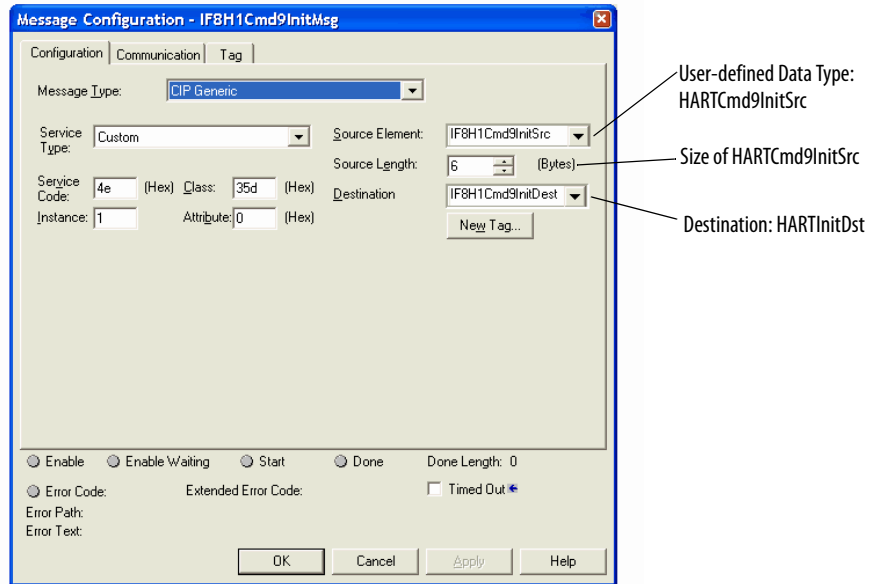

This figure shows the Message Path Browser dialog box.

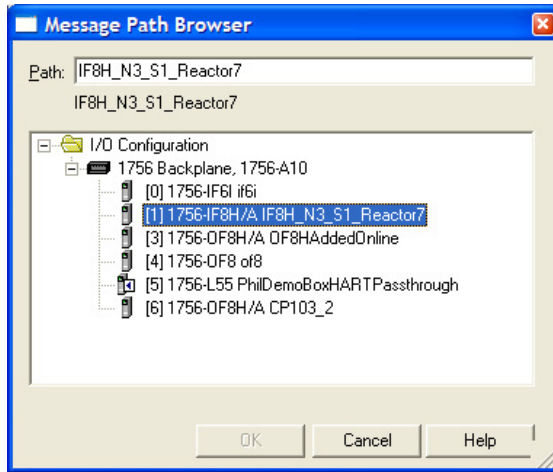

See the query-message configuration dialog box.

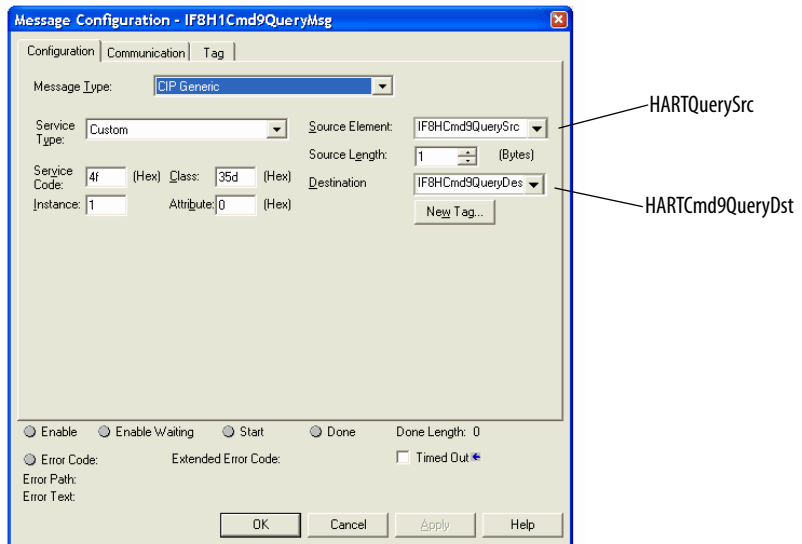

See the dialog box that shows tags. The data types are explained next.

Name	Data Type	Style	Description
Local:8:0	AB:1756_OF8H:0:0		
of8h_ApplyConfig	BOOL	De...	
of8h_slot3_Config	Of8h_ConfigurationBlock		
of8h_slot3_Input	of8h_HARTPV		Input Tag for 1756_OF8H
of8h_slot3_Output	Of8h_OutputBlock		
PassThroughCMD9InitSrc	PassThroughCMD9SrcType		bytes of HART CMD 9 request
PassThroughCMD9InitDst	PassThroughInitDstType		
PassThroughInitMsg	MESSAGE		
PassThruSendIt	BOOL	De...	
PassThroughQueryMsg	MESSAGE		
PassThroughQueryCMD9Src	PassThroughQuerySrcType		
PassThroughQueryCMD9Dst	PassThroughQueryCMD9DstType		
PassThroughQueryCmd9ValuesLogixFormat	PassThroughCMD9RspLogixFormat...		HART Command 9 Values in...
Scratch	REAL	Float	

See the dialog boxes that show the data-type definition and structure examples that are used for the following:

- Init message
 - Source (user-defined data type: HARTCmd9InitSrc)
 - Destination (HARTInitDst Type)
- Query message
 - Source (HARTQuerySrc Type)
 - Destination (HARTCmd9QueryDst Type)

These figures show the HART command 9 example dialog boxes.

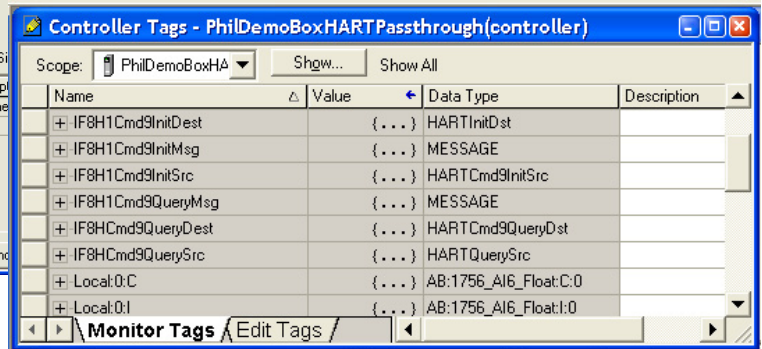
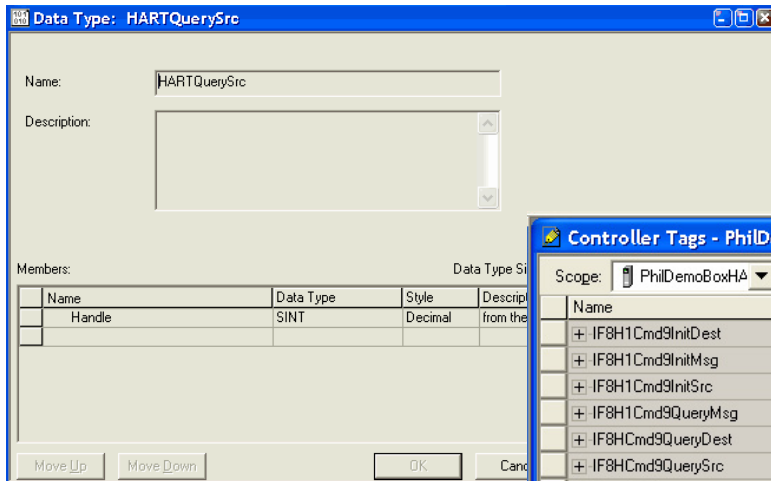
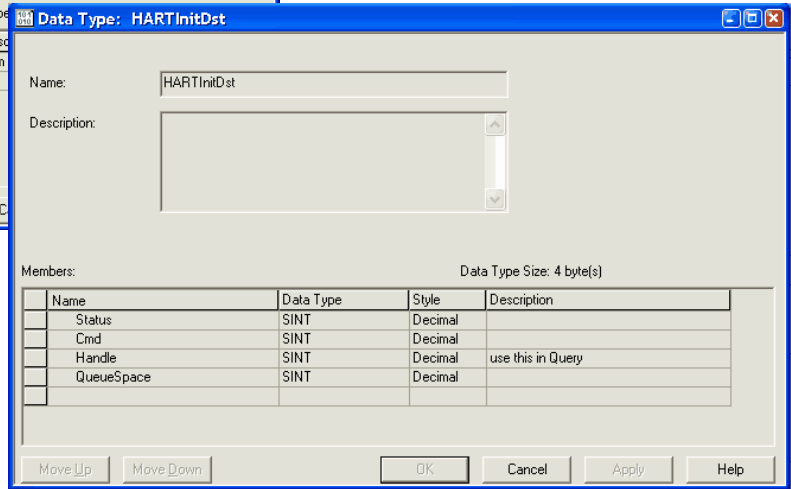
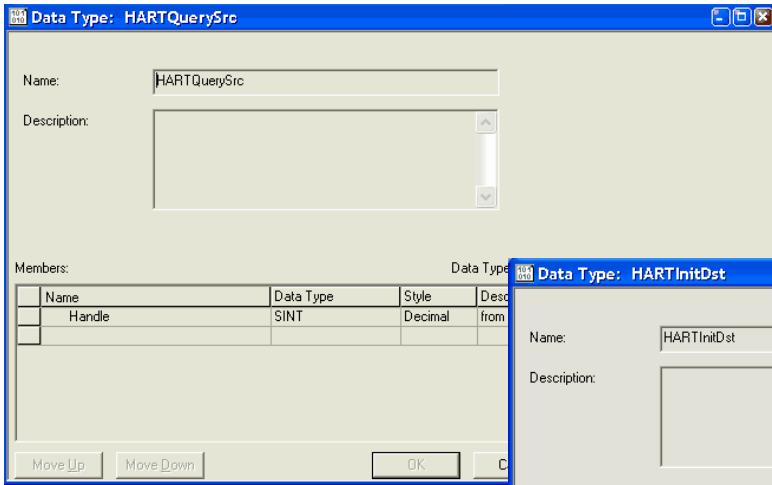

HART Modules Used with Asset Management Software

These topics are discussed in this chapter.

Topic	Page
Considerations for Asset Management Systems	199
Frequently Asked Questions	200

Considerations for Asset Management Systems

The following must be considered before using the I/O modules with asset management systems, such as FactoryTalk® AssetCentre or Endress+Hauser FieldCare systems.

- HART must be enabled before any asset management system access is possible, including scanning for multiplexers, if supported by your asset management software. You do not need to include HART PV or HART by Channel data in your input tag. You must check the Enable HART box on the Configuration tab of the Module Properties dialog box, however.
- The Logix controller must be connected to the I/O module. If the Logix controller is not connected, the module configuration was not sent to the HART module, and the channel is not yet configured for HART access.
- If you use a handheld HART communicator and configuration tool, such as Rosemount 275 or Meriam, configure the tool as the secondary master. The Meriam handheld has a high-speed mode, which assumes it is the only master present. In this mode, the handheld can conflict with the I/O module. Usually, the Meriam handheld automatically detects the proper setting, but if not, set it manually.
- The ConfigurationChanged indication in the Field Device Status is automatically reset by the I/O module. Asset management systems can miss this indication if they are offline at the time of a change.
- A separate configuration-changed indication is in the field device status for the primary master (1756-IF8H, 1756-IF8IH, 1756-IF16, or 1756-IF16IH module) and secondary master (handheld, for example). The I/O modules do not reset the secondary master configuration changed status.

HART traffic from asset management pass-through messages or from secondary masters slows the update rate of HART data in the controller or other pass-through message clients. In the 1756-IF8H, 1756-IF8IH,

1756-OF8H, or 1756-OF8IH modules, extra traffic on one channel also affects other channels.

Frequently Asked Questions

Read this section for answers to frequently asked questions.

How do you use ControlLogix® HART analog I/O modules as part of an asset management system?

HART I/O modules let most asset management software packages communicate through the modules to HART field devices. Use RSLinx software to let the asset management software communicate through the NetLinx networks and 1756 backplane.

Which RSLinx® software is required to support asset management software?

You need RSLinx Classic software with a Professional, Gateway, or OEM activation.

What else is required to use asset management software with a ControlLogix HART analog I/O module?

For Field Device Tool (FDT)/Device Type Manager (DTM) based asset management software such as E+H FieldCare, you use communication DTMs from Rockwell Automation. These same communication DTMs also work in FactoryTalk AssetCentre software. For non-FDT/DTM based asset management software, such as Emerson AMS, use Connects software, available from Spectrum Controls <http://www.spectrumcontrols.com/>.

What is FDT/DTM?

FDT/DTM is a technology for managing intelligent devices.

E+H FieldCare asset management software is an FDT frame application. The frame application runs the DTM files. The DTM files are executable files that are provided by control and device vendors. There are communication DTMs and device DTMs.

We provide communication DTMs for components in the integrated architecture. Companies such as Endress+Hauser and Metso provide device DTMs for their instruments and valves. The device DTMs provide visualization of the parameters that are necessary to configure, monitor, and maintain the devices.

See <http://www.fdtgroup.org> for more information on FDT/DTM technology and to search for registered DTMs.

What communication DTMs are used with the ControlLogix HART analog I/O modules?

Go to the Rockwell Automation Product Compatibility and Download Center (<http://www.rockwellautomation.com/rockwellautomation/support/pcdc.page>), click the Download link, and search for DTM to obtain the DTMs.

Can I get asset management software from Rockwell Automation?

FactoryTalk AssetCentre provides you with a centralized tool for securing, managing, versioning, tracking and reporting automation related asset information across your entire facility. It can do this automatically, with limited additional management oversight or work from employees. FactoryTalk AssetCentre can impact uptime, productivity, quality, employee safety, or regulatory compliance. For more information, see <http://www.rockwellautomation.com/rockwellsoftware/products/factorytalk-asset-center.page?>

What version of Connects software by Spectrum Controls is needed for the ControlLogix HART analog I/O modules?

Use Spectrum Connects software, version 6.0 or later. This software is needed only for asset management software that is not FDT/DTM-based.

What if a DTM is not available for my HART field device?

A generic DTM is available (included with FieldCare) that provides basic access to devices.

Notes:

Use Ladder Logic to Unlatch Alarms and Reconfigure Modules

These topics are discussed in this chapter.

Topic	Page
Using Message Instructions	203
Unlatch Alarms in the 1756-IF8H or 1756-IF8IH Module	209
Unlatch Alarms in the 1756-OF8H or 1756-OF8IH Module	211
Reconfigure a Module	213

The information in this chapter applies only to the 1756-IF8H, 1756-IF8IH with Configure HART Device = No, 1756-OF8H, and 1756-OF8IH modules. Alarms are not available in the 1756-IF16H, 1756-IF16IH, or 1756-IF8IH modules when Configure HART Device = Yes.

Using Message Instructions

In ladder logic, you can use message instructions to send occasional services to any ControlLogix® I/O module. Message instructions send an explicit service to the module and cause specific behavior to occur, for example, the unlatching of a high alarm.

Message instructions maintain the following characteristics:

- Messages use unscheduled portions of system communication bandwidth.
- One service is performed per instruction.
- Performing module services does not impede module functionality, such as sampling inputs or applying new outputs.

Processing Real-time Control and Module Services

Services that are sent via message instructions are not as time critical as the module behavior defined during configuration and maintained by a real-time connection. Therefore, the module processes messaging services only after the needs of the I/O connection are met.

For example, you want to unlatch all process alarms on the module, but real-time control of your process still occurs using the input value from that same channel. Because the input value is critical to your application, the module prioritizes the sampling of inputs ahead of the unlatch service request. This prioritization lets input channels be sampled at the same frequency and the process alarms be unlatched in the time between sampling and producing the real-time input data.

One Service Performed Per Instruction

Message instructions cause a module service to be performed once per execution. For example, if a message instruction sends a service to the module to unlatch the high high alarm on a particular channel, the high high alarm for that channel unlatches. The alarm can be set on a subsequent channel sample. The message instruction must then be re-executed to unlatch the alarm a second time.

Creating a New Tag

Do these steps to create a tag by writing ladder logic in the Main Routine.

1. Double-click MainRoutine (if necessary, expand the MainProgram by clicking the '+' sign).

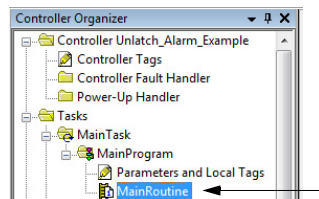

2. Add a message instruction to a rung by clicking the MSG button MSG on the tool bar above the ladder project.
3. Create a tag for the message instruction that you are adding.
 - a. Right-click the question mark (?).
 - b. Choose New Tag.

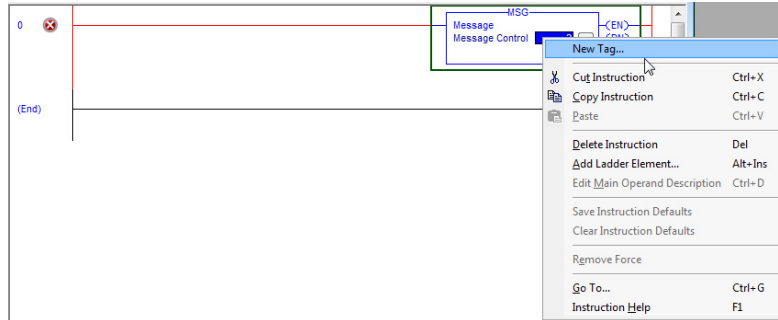

The New Tag dialog box appears.

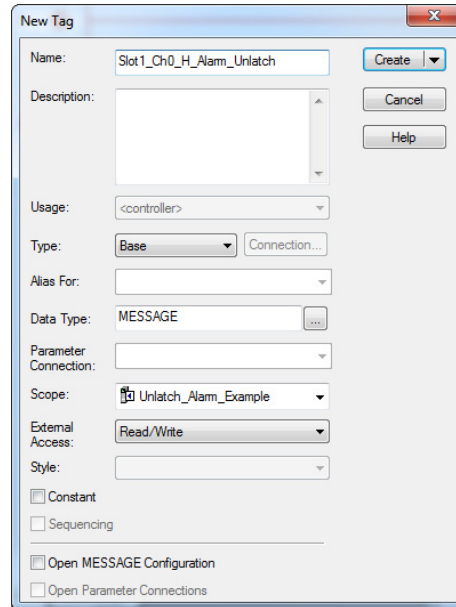

4. On the New Tag dialog box, complete these procedures:
 - a. Name the tag.
 - b. Click Base for tag type.
 - c. Click Message data type.
 - d. Click Controller scope (to create message tags you must use Controller scope).

IMPORTANT We suggest you name the tag to indicate the module service that the message instruction sends. In the example, the message instruction is used to unlatch a high alarm, and the tag name reflects this.

5. Click OK.

Enter Message Configuration

After you create a tag, enter message configuration.

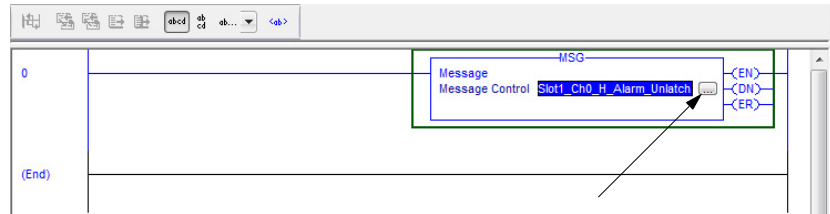

The small box with the ellipsis provides access to the Message Configuration dialog box.

There are two dialog boxes on which you enter message configuration:

- Configuration
- Communication

The purpose and setup of each dialog box is explained on the following pages.

IMPORTANT The Studio 5000 Logix Designer® application defaults information, such as the following, depending on the message type:

- Service type
- Service code
- Class
- Instance
- Attribute
- Source element
- Source length
- Destination

You are required to choose a Service type and configure the Instance field. Instance represents the module channel on which the service is performed, if appropriate.

The Configuration tab provides information on what module service to perform and where to perform it. For example, use this dialog to unlatch high high alarms (module service) on channel 0 of a module (where to perform service).

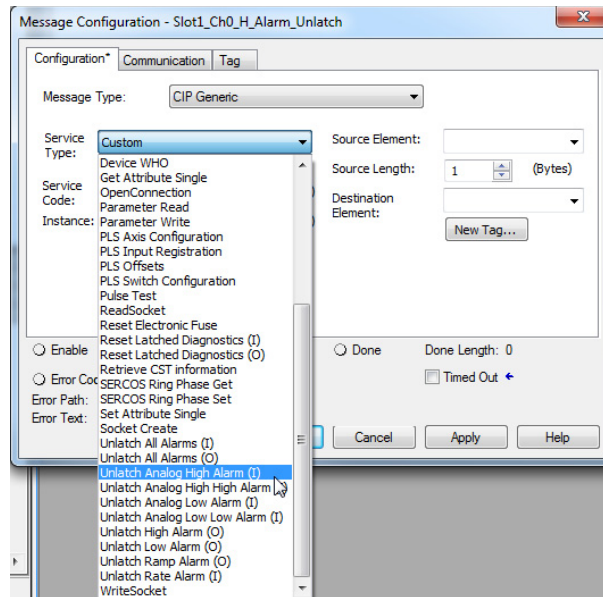

You select a service type by clicking the pull-down menu. A list of available services includes to unlatch high high, high, low low, low, low, ramp, and rate alarms.

The Communication tab provides information on the path of the message instruction. For example, the slot number of a 1756-IF6I module distinguishes exactly for which module a message is designated.

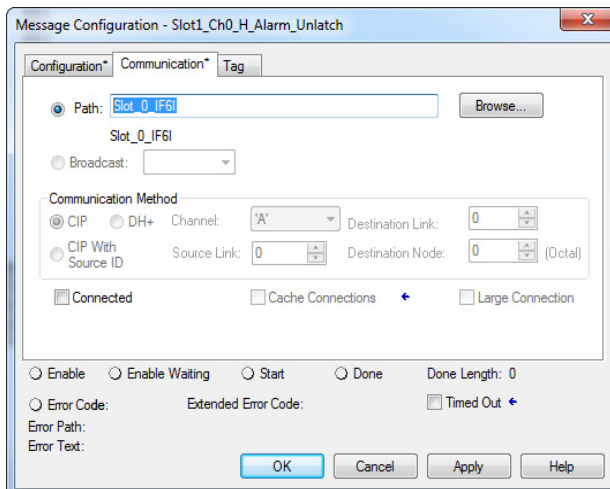

IMPORTANT Click Browse to see a list of the I/O modules in the system.

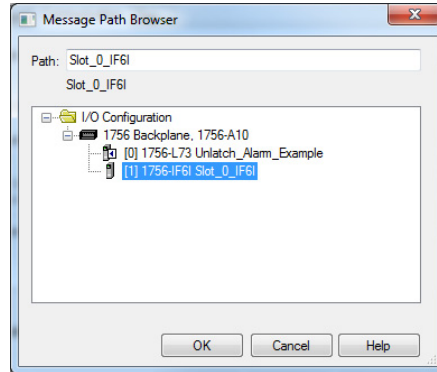

Choose a path when you choose a module from the list.

Name an I/O module during initial module configuration to choose a path for your message instruction.

Unlatch Alarms in the 1756-IF8H or 1756-IF8IH Module

The example ladder logic rungs 0...4 show how to unlatch the following alarms:

- Channel 0 High high alarm - Rung 0
- Channel 0 High alarm - Rung 1
- Channel 0 Low alarm - Rung 2
- Channel 0 Low low alarm - Rung 3
- Channel 0 Rate alarm - Rung 4

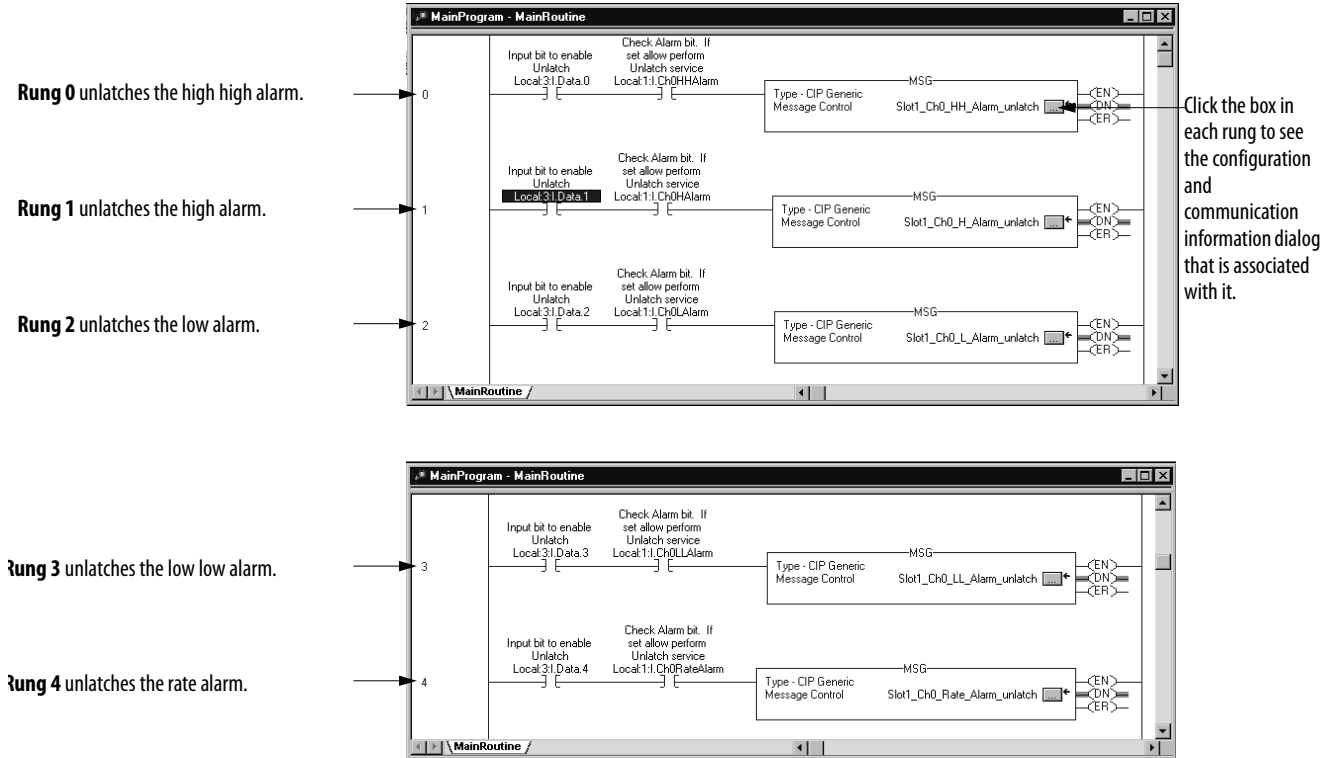

IMPORTANT An I/O module must be configured to latch alarms, before you can perform unlatch services using ladder logic. If a module that is not configured to latch alarms receives an unlatch service, the message instruction errors.

All alarms for channel 0 can be unlatched simultaneously with one message instruction by leaving the Attribute box blank.

Choose a service type and configure the instance.

Instance 1 is for channel 0.

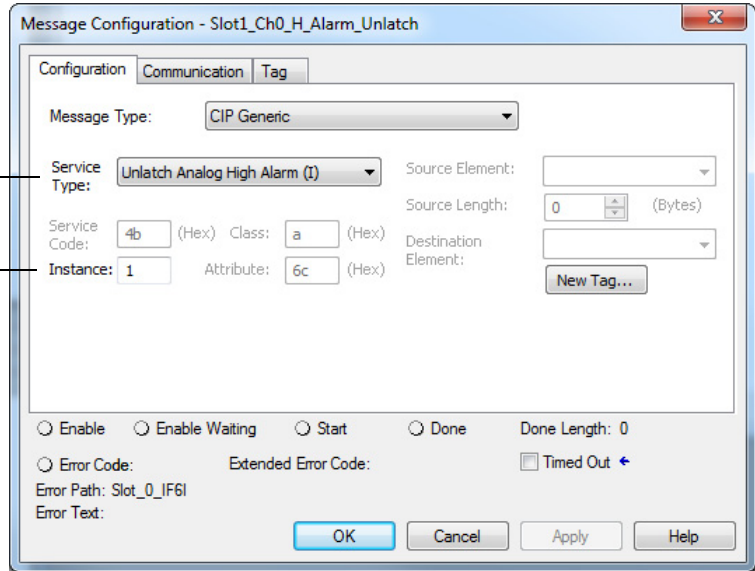

The example shows the communication path for Rung 0

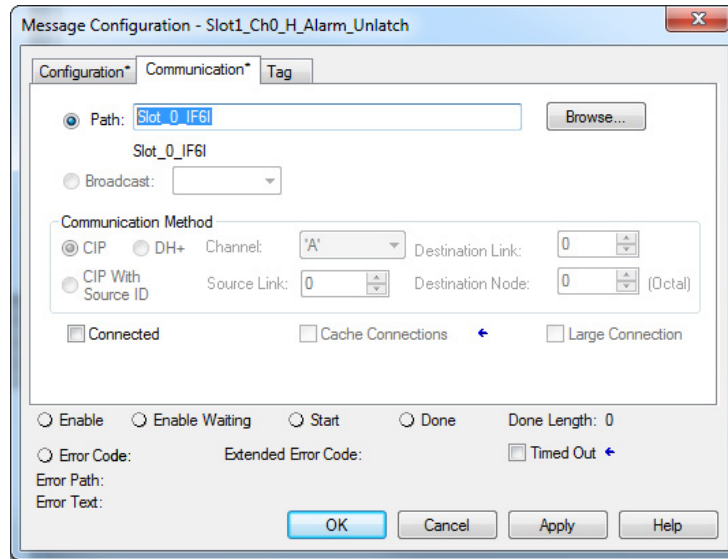

IMPORTANT Name an I/O module to set the message path under the communication dialog for that module.

Unlatch Alarms in the 1756-OF8H or 1756-OF8IH Module

The example ladder logic rungs 5...7 show how to unlatch the following alarms.

- High limit alarm - Rung 5
- Low limit alarm - Rung 6
- Ramp alarm - Rung 7

Rung 5 unlatches the high limit alarm.

Rung 6 unlatches the low limit alarm.

Rung 7 unlatches the ramp alarm.

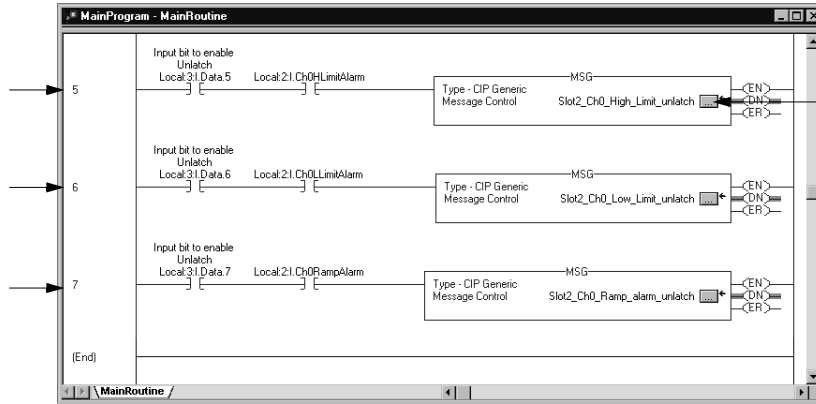

Click the box in each rung to see the configuration and communication information dialog that is associated with it.

The example shows the Configuration dialog box for Rung 5. Choose a service type and configure the instance.

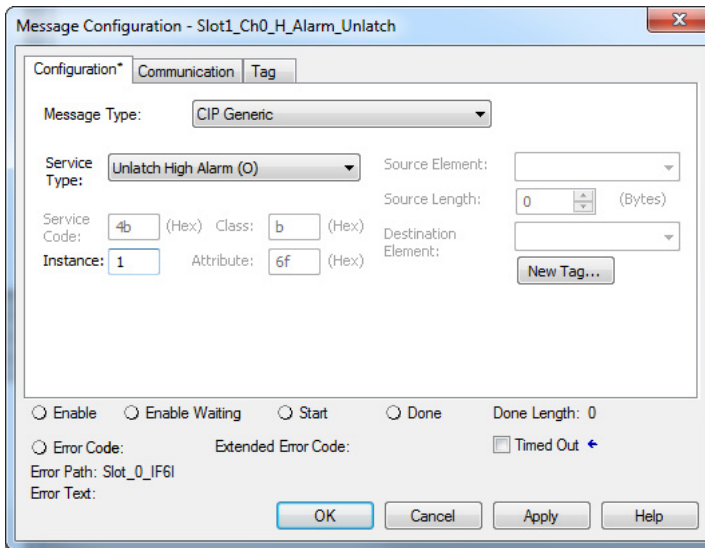

The example shows the communication path for Rung 5

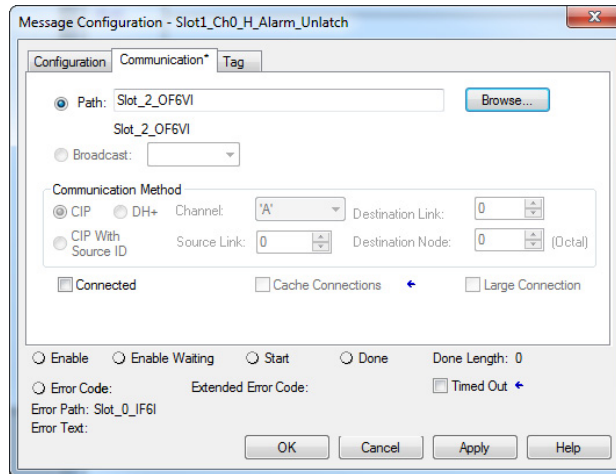

IMPORTANT Name an I/O module to set the message path under the communication dialog for that module.

Reconfigure a Module

It is sometimes advantageous to change the functional operation of a module in the ControlLogix system automatically via the user program rather than using the Logix Designer application to reconfigure a module. This way, changes in the process can dictate when the reconfiguration takes place rather than the user performing that function manually.

IMPORTANT Limit reconfiguration of analog modules via ladder to functions that involve **the changing of values only**. We do not recommend use of ladder logic to enable or disable features. Use the Logix Designer application to enable or disable these features.

Use the steps in this example when reconfiguring a module via ladder logic.

1. Move new configuration parameters to the Configuration portion of the tag structure that is associated with the module.
2. Use a message instruction to send a Reconfigure Module service to the same module.

Before the new configuration parameters are sent to the module, make sure that their relationship to each other is in a format the module accepts (see [Table 107](#) and [Table 108](#)).

The tables below list module parameters that you can change via ladder logic:

Table 107 - Analog Input Module Parameters

Feature	Restriction
High engineering value	Must not be equal to low engineering value
Low engineering value	Must not be equal to high engineering value
High-High alarm value	Must be greater than or equal to high alarm value
High alarm value	Must be greater than low alarm value
Low alarm value	Must be less than high alarm value
Low-Low alarm value	Must be less than or equal to low alarm value
Deadband	Must be less than half of high alarm minus low alarm

Table 108 - Analog Output Module Parameters

Feature	Restriction
High clamp value ⁽¹⁾	Must be greater than low clamp value
Low clamp value ⁽¹⁾	Must be less than high clamp value

(1) The values for user-defined state at Fault or Program (set during initial configuration) must fall within the range of the High and Low Clamp values.

Notes:

Troubleshoot the Module

This chapter discusses these topics.

Topic	Page
Use Module Indicators	215
General Troubleshooting Tips	216
Use the Logix Designer Application to Troubleshoot a Module	220
Module Configuration Errors	221
Remove the Module	224

Use Module Indicators

HART analog I/O modules have indicators to show module status. The illustration shows the indicators on a HART input module.

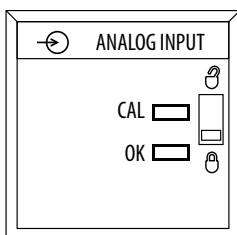

ControlLogix® modules use status indicators as shown in [Table 109](#).

Table 109 - 1756-IF8H Status Indicators

OK Status Indicator State	CAL Status Indicator State	Module State	Notes
Red steady	Green steady	Power on/initialization	Initial state. Status indicator power-on test
Green blinking	Off	Normal operation	The module has passed internal diagnostics, but is not currently performing connected communication
Green steady	Off	Normal operation	Normal run mode; inputs being multicast
Green blinking (if not connected) Green steady (if connected)	Green blinking fast with no pauses	Calibration	Calibration in progress
Red blinking	Off	Lost connection	Communication between controller and module has been lost (timed out)
Red blinking	Green steady	Firmware update	Firmware update in progress
Red steady	Off	Fault	Hardware fault; check to see if module must be replaced
Off	Off	Abnormal	Hardware fault
Orange	Off	Abnormal	Hardware fault
Red steady	Green blinking with pauses	Fault	Module fault - see blink codes ⁽¹⁾

(1) Under fault conditions the module specifies the fault via the CAL status indicator blink code as described in [Table 110](#).

Table 110 shows CAL indicator blink codes.

Table 110 - CAL Indicator Blink Codes

If OK Is	And CAL Is	Condition	Recommended Action
Red	Flashing Green	Firmware Download in Process	Wait for the download to complete.
Red	3 Blinks	ASIC EEPROM CRC is not valid	Nonrecoverable - send the module in for repair.
Red	5 Blinks	Boot code section has failed the CRC check	Nonrecoverable - send the module in for repair
Red	6 Blinks	Application code section has failed the CRC check.	Try reprogramming the module firmware. If condition persists, send the module in for repair.
Red	9 Blinks	Stored calibration data is corrupt and cannot be read. No calibration is applied to input data.	Major nonrecoverable - send the module in for repair
Red	10 Blinks	Module firmware watchdog timer has timed out.	Try resetting the module. If the condition persists, send the module in for repair.
Red	13 blinks	HART processor hardware fault. A communication error has occurred between the main CPU and HART CPU.	Nonrecoverable - send the module in for repair.
Red	14 blinks	HART CPU firmware fault. The HART CPU detected a fault and communicated it to the main CPU.	Nonrecoverable - send the module in for repair.

To see fault status, click the Module Info tab on the Module Properties dialog box in the Studio 5000 Logix Designer® application. A channel fault, such as wire off, is displayed as a ‘Recoverable’ minor fault.

General Troubleshooting Tips

When troubleshooting, consider these typical problems:

- Check the Enable HART box in the Logix Designer application if you want any HART communication access to the channel. This configuration is required for communication from asset management and pass-through messages.
- Choose an Input Tag Data Format that includes HART if you want to use the secondary process variables and device health information in your controller or display it in FactoryTalk® View software.
- On the 1756-IF8H module, put a jumper wire from IN0- to I-RTN-0 if you use 4...20 mA devices.
- On the 1756-IF8H 1756-IF16H, and 1756-IF16IH modules, do not tie RTN-X together if you are mixing 2-wire and 4-wire HART devices on the same module.
- Channel buttons in the Logix Designer application apply only to the currently displayed dialog.



- From RSLinx software, if you click RSWho and see 1756-Module, install the EDS file from the Rockwell Automation Product Compatibility and Download Center. Go to <http://www.rockwellautomation.com/support/> and click the Product Compatibility and Download Center link under Resources.

- In some versions of the Logix Designer application or RSLogix 5000® software, the profiles for the ControlLogix HART analog I/O modules are not included.
Go to <http://www.rockwellautomation.com/support/> and click the Product Compatibility and Download Center link under Resources to find and download the Add-on Profile.
- In RSLogix 5000 software, version 15 and later or the Logix Designer application, with an error about ControlNet Attribute, use Scheduled Connections, or shutdown and restart the RSLogix 5000 software or the Logix Designer application.
- If you cannot find HART data, look in subfield Local:7:I.HART at bottom of the tag or in chassis:7:I.Chxx.PV for data that are grouped by channel.

When troubleshooting, consider these more obscure problems.

- The same device appears to be connected to every channel because a wiring problem causes signals to get connected across channels. In some cases, loose IRET wires cause the path to ground to flow through other channels.
- If Keep HART Replies for XX seconds is set small – less than 5 seconds, the module throws away replies before you get a chance to retrieve them. This action affects both MSG pass-through messages and PC-based asset management, such as FieldCare software. We recommend 15 seconds for this parameter.
- Be sure that you have a HART device. Foundation Fieldbus, PROFIBUS PA, and plain 4...20 devices look the same on the outside and power up OK.
- Write protect jumper is not reported correctly. This condition gets refreshed only if the device reports it changed. E&H and Rosemount devices do not. Disable HART then re-enable HART to get it refreshed on the HART Device Info dialog.

For pass-through message troubleshooting issues, use these tips:

- Check module-specific online help.
- Copy the Handle to the Query.
- Check sizes of MSG and HART command.
- Check packing, alignment, and byte ordering.
- Use MsgReady.
- Name tags and UDTs similarly to group them together for convenience. For example, start the related tags with the same prefix.
- Check .ER and Status.

For input tag troubleshooting, use these tips:

- Local:7:I.Ch0Fault – if 1, suspect wiring/instrument problem.
- Local:7:I.Ch0HARTFault – if 1, check Local:7:C.HARTEn (Enable HART).
- Local:7:I.HART.Ch0DeviceStatus.Init – HART is enabled, but still trying to get a response from device.
- Local:7:I.HART.Ch0DeviceStatus.Fail – HART is disabled, or not responding.
- Local:7:I.HART.Ch0DeviceStatus.CurrentFault – the measured mA current doesn't match what is reported via HART. A recent change in value can cause this condition. It is intended to indicate a current leak, such as water in the conduit.
- Local:7:I.HART.Ch0DeviceStatus.ResponseCode – if negative, there is some communication problem. If positive, device is indicating some problem with the command. 16#40 means command not supported.
- Local:7:I.HART.Ch0DeviceStatus.FieldDeviceStatus – 0 is good; refer to Help or see the [Table 117 on page 229](#) for more information.
- Local:7:I.HART.Ch0PVStatus – 16#C0 is good. 0 is bad. This condition could indicate a communication problem or something wrong with the device. For example, with SVStatus, this condition could mean that the device does not support multiple measurements.

When working with the HART Device Info dialog for troubleshooting, use these tips:

- HART Initializing means that HART is enabled, but not communicating. If this condition persists for 10 seconds after you click Refresh several times, suspect a HART communication problem or no device.
- Be sure that a channel is HART Enabled.
- Be sure that values appear, meaning HART communication is okay.
- Check PV values Local:7:I:HART.Ch0PV or Local:12:I.Ch00.Data for numbers that are changing.
- Check analog values Local:7:I:Ch0Data or Local:12:I.Ch00.Data for numbers that are changing; for the 1756-OF8H module, check that is valid.
- You must have a Logix connection for asset management to deliver the configuration to the module. From the Module Properties dialog, click HART Device Info to see if it shows information.

The words 'HART Initializing' appear here.

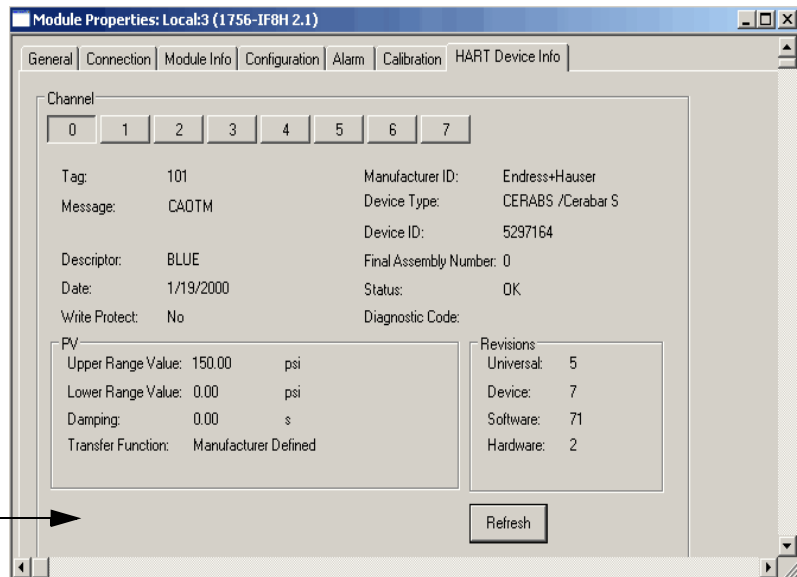

Be sure a channel is HART enabled.



Use the Logix Designer Application to Troubleshoot a Module

In addition to the status displayed on the module, the Logix Designer application alerts you to fault conditions in one of these ways:

- Warning symbol in the I/O Configuration next to the module - This symbol appears when the connection to the module is broken

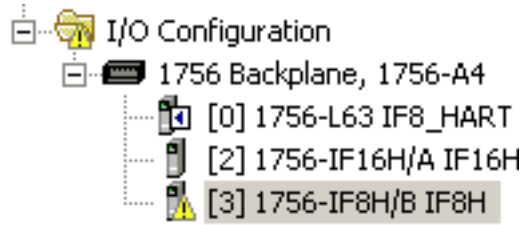

- Fault message in a status line
- Notification in the Tag Monitor
 - General module faults
 - Diagnostic faults
- Status on the Module Info Page

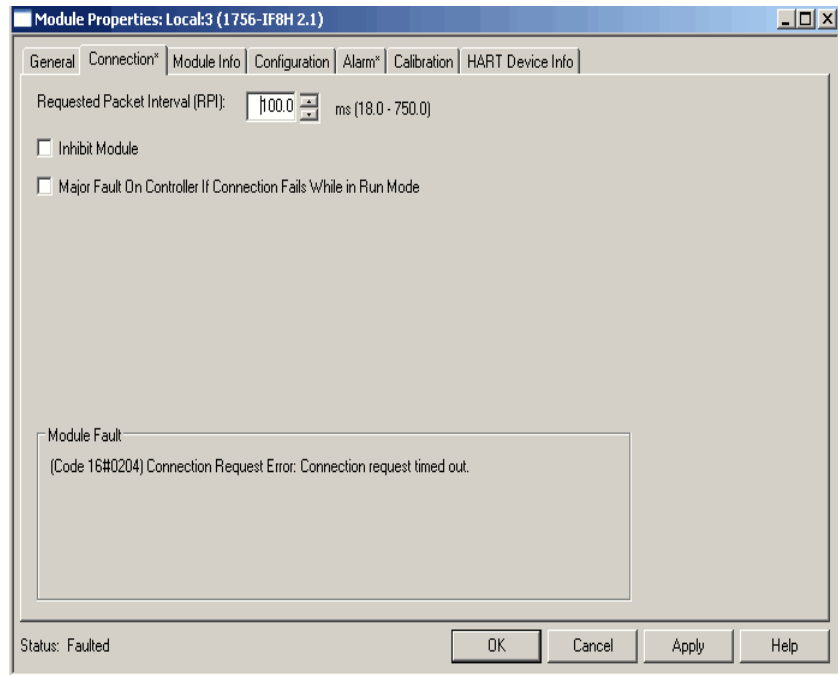

Module Configuration Errors

In the Logix Designer application, if “(Code 16#0009) Module Configuration Rejected: Parameter Error” is displayed on the Connection tab, the additional fault code value describes the configuration error.

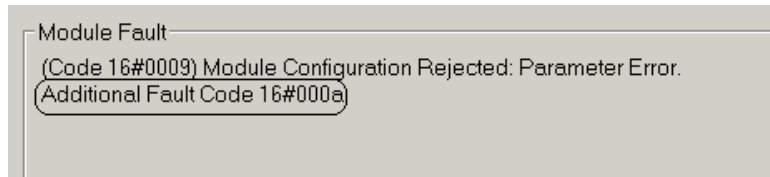

Additional Fault Codes - Module Level

[Table 111](#) shows error codes that are used by ControlLogix HART Analog I/O modules for module level conditions. These are conditions that do not occur in a specific channel.

Table 111 - HART analog I/O Module Level Error Codes

Additional Fault Codes	Description
16#0001	Configuration revision number invalid Valid numbers are 0 or 1
16#0002	Filter value invalid
16#0003	RTS invalid
16#0004	Pass-through handle timeout
16#1001	Configuration does not match In a multiple owner setup, with the configuration revision number set to 1, the configurations must match

TIP The 16# means that this number is Hex display style.

Additional Fault Codes - Channel Level

Each module has channel level error codes that are specific to the individual modules. These channel level error codes, which display in the Module Fault box on the Connection tab dialog box, are described in [Table 112](#)...[Table 114](#).

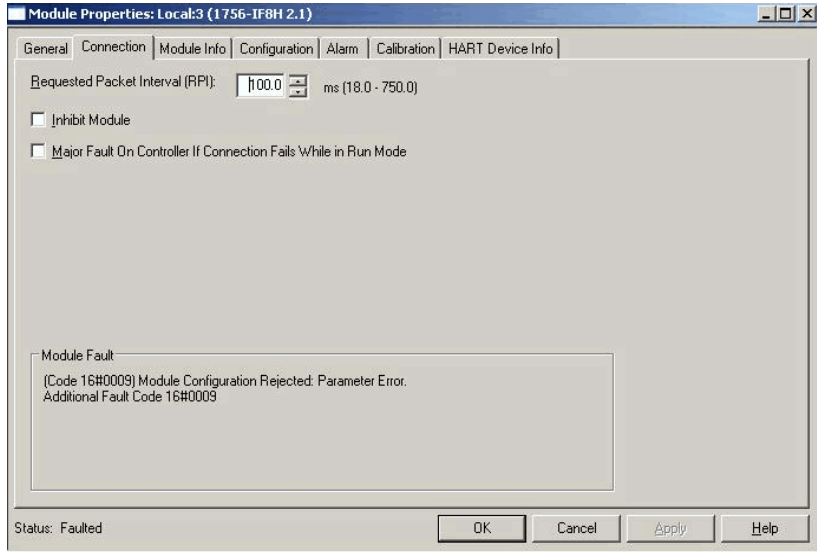

Table 112 - 1756-IF8H, 1756-IF8IH Channel Level Error Codes
 Channel x Extended Status = Channel 0 Error Value + (x*16)

	Channel								Channel Status
	0	1	2	3	4	5	6	7	
Additional Fault Codes	16#0005	16#0015	16#0025	16#0035	16#0045	16#0055	16#0065	16#0075	Process Alarm Latch Set and Disable All Alarms Set
	16#0006	16#0016	16#0026	16#0036	16#0046	16#0056	16#0066	16#0076	Rate Alarm Latch Set and Alarm Disable Set
	16#0007	16#0017	16#0027	16#0037	16#0047	16#0057	16#0067	16#0077	Invalid Input Range
	16#0008	16#0018	16#0028	16#0038	16#0048	16#0058	16#0068	16#0078	Invalid Digital Filter
	16#0009	16#0019	16#0029	16#0039	16#0049	16#0059	16#0069	16#0079	Invalid Rate Alarm
	16#000A	16#001A	16#002A	16#003A	16#004A	16#005A	16#006A	16#007A	High Signal and/or Low Signal outside of selected input range
	16#000B	16#001B	16#002B	16#003B	16#004B	16#005B	16#006B	16#007B	High Signal ≤ Low Signal
	16#000C	16#001C	16#002C	16#003C	16#004C	16#005C	16#006C	16#007C	Sensor Offset set to NaN
	16#000D	16#001D	16#002D	16#003D	16#004D	16#005D	16#006D	16#007D	High Engineering = Low Engineering
	16#000E	16#001E	16#002E	16#003E	16#004E	16#005E	16#006E	16#007E	Invalid HART rate, HART rate fixed at 1:1
	16#000F	16#001F	16#002F	16#003F	16#004F	16#005F	16#006F	16#007F	High Alarm < Low Alarm
	16#0010	16#0020	16#0030	16#0040	16#0050	16#0060	16#0070	16#0080	Low Low Alarm > Low
	16#0011	16#0021	16#0031	16#0041	16#0051	16#0061	16#0071	16#0081	High High alarm < High Alarm
16#0012	16#0022	16#0032	16#0042	16#0052	16#0062	16#0072	16#0082	Invalid Alarm Deadband	

Table 113 - 1756-IF16H and 1756-IF16IH Modules Channel Level Error Codes

Channel x Extended Status = Channel 0 Error Value + (x *16)

		Channel								Channel Status
		0	1	2	3	4	5	6	7	
Extended Fault Codes	16#0007	16#0017	16#0027	16#0037	16#0047	16#0057	16#0067	16#0077	Invalid Input Range	
	16#0008	16#0018	16#0028	16#0038	16#0048	16#0058	16#0068	16#0078	Invalid Digital Filter	
	16#000A	16#001A	16#002A	16#003A	16#004A	16#005A	16#006A	16#007A	High Signal and/or Low Signal outside of selected input range	
	16#000B	16#001B	16#002B	16#003B	16#004B	16#005B	16#006B	16#007B	High Signal ≤ Low Signal	
	16#000C	16#001C	16#002C	16#003C	16#004C	16#005C	16#006C	16#007C	Sensor Offset set to NaN	
	16#000D	16#001D	16#002D	16#003D	16#004D	16#005D	16#006D	16#007D	High Engineering = Low Engineering	
		Channel (cont.)								
		8	9	10	11	12	13	14	15	
Extended Fault Codes	16#0087	16#0097	16#00A7	16#00B7	16#00C7	16#00D7	16#00E7	16#00F7	Invalid Input Range	
	16#0088	16#0098	16#00A8	16#00B8	16#00C8	16#00D8	16#00E8	16#00F8	Invalid Digital Filter	
	16#008A	16#009A	16#00AA	16#00BA	16#00CA	16#00DA	16#00EA	16#00FA	High Signal and/or Low Signal outside of selected input range	
	16#008B	16#009B	16#00AB	16#00BB	16#00CB	16#00DB	16#00EB	16#00FB	High Signal ≤ Low Signal	
	16#008C	16#009C	16#00AC	16#00BC	16#00CC	16#00DC	16#00EC	16#00FC	Sensor Offset set to NaN	
	16#008D	16#009D	16#00AD	16#00BD	16#00CD	16#00DD	16#00ED	16#00FD	High Engineering = Low Engineering	

Table 114 - 1756-OF8H and 1756-OF8IH Modules Channel Level Error Codes

Channel x Extended Status = Channel 0 Error Value + (x *22)

		Channel								Channel Status
		0	1	2	3	4	5	6	7	
Additional Fault Codes	16#0005	16#001B	16#0031	16#0047	16#005D	16#0073	16#0089	16#009F	Bad Ramp Latch	
	16#0006	16#001C	16#0032	16#0048	16#005E	16#0074	16#008A	16#00A0	Bad Clamp Latch	
	16#000A	16#0020	16#0036	16#004C	16#0062	16#0078	16#008E	16#00A4	Bad Ramp to Idle	
	16#000B	16#0021	16#0037	16#004D	16#0063	16#0079	16#008F	16#00A5	Bad Ramp to Fault	
	16#000C	16#0022	16#0038	16#004E	16#0064	16#007A	16#0090	16#00A6	Invalid Input Range	
	16#000D	16#0023	16#0039	16#004F	16#0065	16#007B	16#0091	16#00A7	Bad Max Ramp	
	16#000E	16#0024	16#003A	16#0050	16#0066	16#007C	16#0092	16#00A8	Bad Fault Value	
	16#000F	16#0025	16#003B	16#0051	16#0067	16#007D	16#0093	16#00A9	Bad Idle Value	
	16#0010	16#0026	16#003C	16#0052	16#0068	16#007E	16#0094	16#00AA	Signal Out of Range	
	16#0011	16#0027	16#003D	16#0053	16#0069	16#007F	16#0095	16#00AB	Low Signal Greater or Equal to High Signal	
	16#0012	16#0028	16#003E	16#0054	16#006A	16#0080	16#0096	16#00AC	Sensor Offset set to NaN	
	16#0013	16#0029	16#003F	16#0055	16#006B	16#0081	16#0097	16#00AD	High Engineering Equal to Low Engineering	
	16#0014	16#002A	16#0040	16#0056	16#006C	16#0082	16#0098	16#00AE	Invalid HART Rate	
	16#0015	16#002B	16#0041	16#0057	16#006D	16#0083	16#0099	16#00AF	Bad Clamp	

Remove the Module

Follow these steps to remove a module.

1. Push in the top and bottom locking tabs.

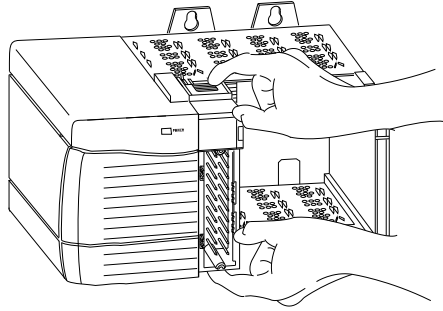

20856

2. Pull the module out of the chassis.

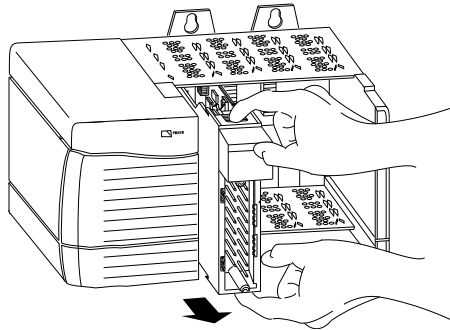

20857

Use 1492 Wiring Systems with Your Analog I/O Module

Wiring System Uses

As an alternative to buying removable terminal blocks and connecting the wires yourself, you can buy a wiring system with these items:

- Analog interface modules (AIFM) that mount on DIN rails and provide the output terminal blocks for the I/O module - Use the AIFMs with the pre-wired cables that match the I/O module to the interface module. For a list of the AIFMs available for use with ControlLogix® analog I/O modules, see the table that provides the list.
- I/O module-ready pre-wired cables - One end of the cable assembly is a removable terminal base that plugs into the front of the I/O module. The other end has individually color-coded conductors that connect to a standard terminal block. For a list of the pre-wired cables available for use with ControlLogix analog I/O modules, see the table that provides the list.

Figure 36 - Analog Interface Modules

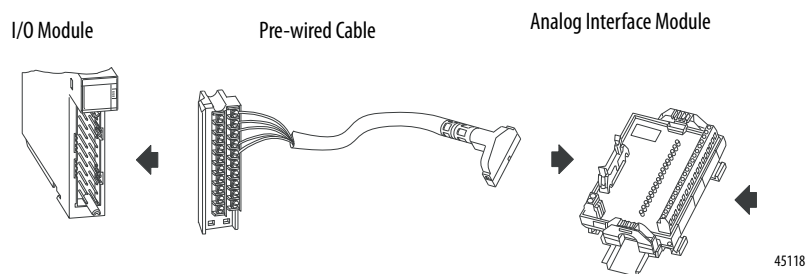

IMPORTANT The ControlLogix system has been agency certified using the ControlLogix removable terminal bases (RTBs) only (for example, catalog numbers 1756-TBCH, 1756-TBNH, 1756-TBSH, and 1756-TBS6H). Any application that requires agency certification of the ControlLogix system that uses other wiring termination methods can require application-specific approval by the certifying agency.

[Table 115](#) and [Table 116](#) list the AIFMs and pre-wired cables that can be used with the 1756-IF8H, 1756-IF16H, 1756-IF16IH, and 1756-OF8H modules.

IMPORTANT For the latest list, see the Digital/Analog Programmable Controller Wiring Systems Technical Data, publication [1492-TD008](#).

Table 115 - Analog Interface Module and Pre-wired Cables

I/O Cat. No.	Mode	AIFM Cat. No. (Fixed Terminal Block)	AIFM Cat. No. (RTB Socket Assembly)	AIFM Type	Description	Pre-wired Cable ⁽²⁾ (x=cable length)
1756-IF8H 1756-IF8IH	Current	1492-AIFM8-3	1492-RAIFM8-3 ⁽¹⁾	Feed-through	8-channel input or output with 3 terminals/channel	1492-ACABLExUD
		1492-AIFM8-F-5	—	Fused	8-channel input with 24V DC BF indicators and 5 terminals/channel	
	Voltage	1492-AIFM8-3	1492-RAIFM8-3 ⁽¹⁾	Feed-through	8-channel input or output with 3 terminals/channel	1492-ACABLExUC
		1492-AIFM8-F-5	—	Fused	8-channel input with 24V DC BF indicators and 5 terminals/channel	
1756-IF16H	Single-ended Current	1492-AIFM16-F-3	—	Fused	16-channel input with 24V DC BF indicators and 3 terminals/channel	1492-ACABLExUB
1756-OF8H	Current	1492-AIFM8-3	1492-RAIFM-8-3 ⁽¹⁾	Feed-through	8-channel input or output with 3 terminals/channel	1492-ACABLExWB
	Voltage					1492-ACABLExWA
1756-OF8IH	Current	1492-AIFM8-3	1492-RAIFM-8-3 ⁽¹⁾			1492-ACABLExWB
						1492-ACABLExWA

- (1) Compatible RTB plug; 1492-RTB8N (screw-style terminals) or 1492-RTB8P (push-in style terminals). Order plugs separately.
- (2) Cables are available in lengths of 0.5 m, 1.0 m, 2.5 m, and 5.0 m. To order, insert the code for the desired cable length into the catalog number in place of the x: 005=0.5 m, 010=1.0 m, 025=2.5 m, 050=5 m. Example: 1492-ACABLE025TB is for a 2.5 m cable, and the letters TB.

Table 116 - I/O Module-ready Pre-wired Cables

Cat. No. ⁽¹⁾	Number of Conductors ^{(2) (3)}	Conductor Size	Nominal Outer Diameter	Removable Terminal Block at the I/O Module End
1492-ACABLExUB	20 conductors	22 AWG	8.4 mm (0.33 in.)	1756-TBCH
1492-ACABLExUC	9 twisted pairs		6.8 mm (0.27 in.)	
1492-ACABLExUD				
1492-ACABLExWA				
1492-ACABLExWB				
				1756-TBNH

- (1) Cables are available in lengths of 0.5 m, 1.0 m, 2.5 m, and 5.0 m. To order, insert the code for the desired cable length into the catalog number in place of the x: 005=0.5 m, 010=1.0 m, 025=2.5 m, 050=5 m. Example: 1492-ACABLE025TB is for a 2.5 m cable, and the letters TB.
- (2) Each cable for analog I/O has an overall shield with a ring lug on a 200 mm (8.87 in.) exposed drain wire at the I/O module end of the cable.
- (3) Not every connection is always used.

Additional HART Protocol Information

This appendix discusses these topics.

Topic	Page
Message Structure	228
Response Code and Field Device Status	229
HART PV, SV, TV, and FV Status	236

This appendix describes the HART protocol and provides references for additional information about the protocol. Consult the HART protocol specification and vendor-provided documentation for specifics on HART commands.

This appendix provides the following:

- HART protocol background information
- Common practice command sets
- Extended command sets
- References to additional information

HART Field Communication Protocol is widely accepted in the industry as the standard for digitally enhanced 4...20mA communication with smart field instruments. The HART Protocol message structure, command set, and status are discussed in this appendix.

The HART command set is organized into these groups and provides read and write access to a wide array of information available in smart field instruments:

- Universal commands provide access to information that is useful in normal plant operation such as the instrument manufacturer, model, tag, serial number, descriptor, range limits, and process variables. All HART devices must implement universal commands.
- Common practice commands provide access to functions that many devices can carry out.
- Device-specific commands provide access to functions that can be unique to a particular device.

Message Structure

Read this section for a description of transaction procedure, character coding, and message structure of the HART protocol. These correspond to layer 2 (data-link layer) of the OSI protocol reference model.

Master-slave Operation

HART is a master-slave protocol. This means that the master originates each message transaction; the slave (field) device replies when it receives a command message that is addressed to it. The reply from the slave device acknowledges that the command was received and can contain data that the master requested.

Multiple Master Operation

The HART protocol provides for two active masters in a system: one primary and one secondary. The two masters have different addresses. Each can positively identify replies to its own command messages. The 1756-IF8H, 1756-IF8IH, 1756-IF16H, 1756-IF16IH, 1756-OF8H, or 1756-OF8IH module acts as primary master. A secondary master, such as a handheld configuration device, can also be connected.

Transaction Procedure

HART is a half-duplex protocol. After completion of each message, the FSK carrier signal must be switched off to let the other station transmit. The carrier control timing rules state the following:

- Not to turn on the carrier more than 5 bit times before the start of the message (the preamble)
- Not to turn off more than 5 bit times after the end of the last byte of the message (the checksum)

The master is responsible for controlling message transactions. If there is no reply to a command within the expected time, the master retries the message. After a few retries, the master aborts the transaction, because presumably the slave device or the communication link has failed.

After each transaction is completed, the master pauses for a short time before sending another command, to provide an opportunity for the other master to break in if it wishes. This way, two masters (if they are present) take turns communicating with the slave devices. Typical message lengths and delays allow two transactions per second.

Burst Mode

The ControlLogix® HART analog modules do not support burst mode.

Response Code and Field Device Status

Two bytes of status that are also called the response code and field device status are included in every reply message from a field or slave device. These two bytes convey communication errors, command response problems, and field device status. If an error is detected in the outgoing communication, the most significant bit (bit 7) of the first byte is set to 1. The details of the error are also reported in the rest of that byte. The second byte is then all zeros.

Communication errors are typically errors that are detected by a UART (parity overrun and framing errors). The field device also reports overflow of its receive buffer and any discrepancy between the message content and the checksum received.

In the Logix Designer application, if the leftmost bit of the ResponseCode is set, it displays a negative number. In this case, the ResponseCode represents a communication fault. Change the display format to hexadecimal to interpret communication status.

If the leftmost bit of the ResponseCode is 0 (value 0...127), then there was no communication error and the value is a ResponseCode from the HART field device. Response codes indicate if the device performed the command. 0 means no error. Other values are errors or warnings. To understand the ResponseCode, contact your HART field device manufacturer or the HART specification.

See [Table 117](#) for descriptions of the response code and the field device status.

Table 117 - Response Codes and Field Device Status

Response Code		Description	
If Bit 7 is	And Bits 6...0 are		
1	16#40	Parity Error	Vertical parity error - The parity of one or more of the bytes received by the device was not odd
1	16#20	Overrun Error	Overrun error - At least one byte of data in the receive buffer of the UART was overwritten before it was read (for example, the slave did not process incoming byte fast enough)
1	16#10	Framing Error	Framing error - The UART did not detect the Stop Bit of one or more bytes received by the device (for example, a mark or 1 was not detected when a Stop Bit should have occurred)
1	16#08	Checksum Error	Longitudinal parity error - The Longitudinal Parity calculated by the device did not match the Check Byte at the end of the message
1	16#04	(Reserved)	Reserved - Set to zero
1	16#02	RX Buffer Overflow	Buffer overflow - The message was too long for the receive buffer of the define
1	16#01	(undefined)	Reserved - Set to zero
0	0	No command specific error	
0	1	(undefined)	
0	3	Value too large	

Table 117 - Response Codes and Field Device Status (continued)

Response Code		Description
If Bit 7 is	And Bits 6...0 are	
0	4	Value too small
0	5	Not enough bytes in command
0	6	Transmitter-specific command error
0	7	In Write-protect mode
0	8	Update Failed - Update In Progress - Set to Nearest Possible Value
0	9	Applied Process Too High - Lower Range Value Too High - Not In Fixed Current Mode
0	10	Applied Process Too Low - Lower Range Value Too Low - MultiDrop Not Supported
0	11	In MultiDrop Mode - Invalid Transmitter Variable Code - Upper Range Value Too High
0	12	Invalid Unit Code - Upper Range Value Too Low
0	13	Both Range Values Out of Limits
0	14	Pushed Upper Range Value Over Limit - Span Too Small
0	16	Access restricted
0	32	Device busy
0	64	Command not implemented

If no error was detected in the outgoing communication, the second byte contains status information that pertains to the operational state of the field or slave device.

Table 118 - Field Device Status Bit Mask Definitions

Bit	Bit Mask	Definition
7	16#80	Device malfunction - The device detected a serious error or failure that compromises device operation
6	16#40	Configuration changed - An operation was performed that changed the configuration of the device
5	16#20	Cold start - A power failure or device reset occurred
4	16#10	More status available - More status information is available via command 48, Read Additional Status Information
3	16#08	Loop current fixed - The loop current is being held at a fixed value and is not responding to process variations
2	16#04	Loop current saturated - The loop current has reached its upper or lower endpoint limit and cannot increase or decrease any further
1	16#02	Non-primary variable out of limits - A device variable that is not mapped to the PV is beyond its operating limits
0	16#01	Primary variable out of limits - The PV is beyond its operating limit

IMPORTANT The 16# means that this number is Hex display style.

Table 119 - HART Universal Commands

Command		Data in Command			Data in Reply			Contained in	
No.	Function	Byte	Data	Type ⁽¹⁾	Byte	Data	Type ⁽¹⁾	Input Tag	CIP MSG
0	Read Unique Identified		None		0 1 2 3 4 5 6 7 8 9...11	254 (expansion) Manufacturer identification code Manufacturer device type code Number of preambles required Universal command revision Device-specific command revision Software version Hardware revision Device function flags ⁽²⁾ Device ID number	(H) (B)		x x x x x x x x x
1	Read primary variable				0 1...4	PV units code Primary variable	(F)	x	x x
2	Read current and percent of range		None		0...3 4...7	Current (mA) Primary variable %	(F) (F)	x x	x x
3	Read current and four (predefined) dynamic variables		None		0...3 4 5...8 9 10...13 14 15...18 19 20...23	Current (mA) PV units code Primary variable SV units code Secondary variable TV units code Third variable FV units code Fourth variable ⁽³⁾		x x x x x x x x	
6	Write polling address	0	Polling address			As in command			
11	Read unique identifier associated with tag	0...5	Tag	(A)	0...11				
12	Read message		None		0...23	Message (32 characters)	(A)		x
13	Read tag, descriptor, date				0...5 6...17 18...20	Tag (8 characters) Descriptor (16 characters) Date	(A) (A) (D)		x x x
14	Read PV sensor information				0...2 3 4...7 8...11 12...15	Sensor serial number Units code for sensor limits and min span Upper sensor limit Lower sensor limit Min span	(B) (F) (F) (F)		
15	Read output information				0 1 2 3...6 7...10 11...14 15 16	Alarm select code Transfer function code PV/range units code Upper range value Lower range value Damping value (seconds) Write-protect code Private-label distributor code	(F) (F) (F)		x x x x x x
16	Read final assembly number		None		0...2	Final assembly number	(B)		x

Table 119 - HART Universal Commands

Command		Data in Command			Data in Reply			Contained in	
No.	Function	Byte	Data	Type ⁽¹⁾	Byte	Data	Type ⁽¹⁾	Input Tag	CIP MSG
17	Write message	0...23	Message (32 characters)	(A)		As in command			
18	Write tag, descriptor, date	0...5	Tag (8 characters)	(A)					
		6...17	Descriptor (16 characters)	(A)					
		18...20	Date	(D)					
19	Write final assembly number	0...2	Final assembly number	(B)					
48	Read additional device status		Starting in HART version 7, the data in the command could be the same as in the reply.		0...5 6...7 8 9 10 11 12 13 14...24	Device-specific status Operational modes Standardized status 0 Standardized status 1 Analog channel saturated Standardized status 2 Standardized status 3 Analog channel fixed ⁽⁴⁾ Device-specific status	s ⁽⁵⁾		x x x x x x x x x

- (1) (A) = Packed ASCII, (B) = 3-byte integer, (D) = Date, (F) = Floating Point (HART format), (H) = HART flag
- (2) Bit 6 = multisensor device. Bit 1 = EEPROM control required. Bit 2 = protocol bridge device.
- (3) Truncated after last supported variable.
- (4) 24 bits each LSB...MSB refers to A0 #1...24.
- (5) Sint []

Table 120 - Common Practice Commands

Command		Data in Command			Data in Reply			Contained in													
No.	Function	Byte	Data	Type ⁽⁶⁾	Byte	Data	Type ⁽⁶⁾	Input Tag	CIP MSG												
33	Read transmitter variables		None		0	Transmitter variable code for slot 0	(F)														
					1	Units code for slot 0															
					2...5	Variable for slot 0															
					6	Transmitter variable code for slot 1															
					7	Units code for slot 1															
					8...11	Variable for slot 1															
					12	Transmitter variable code for slot 2															
					13	Units code for slot 2															
					14...17	Variable for slot 2															
34	Write damping value	0...3	Damping value (seconds)	(F)		As in command	(F)														
										35	Write range values	0...8	Range units code	(F)		(F)					
																		1...4	Upper-range value	(F)	
36	Set upper-range value (= push SPAN button)		None			None															
										37	Set lower-range value (= push ZERO button)										
																		38	Reset 'configuration changed' flag		
39	EEPROM control	0	EEPROM control code ⁽³⁾			As in command															
40	Enter/exit Fixed Current mode	0...3 ⁽¹⁾	Current (mA)	(F)		As in command															
41	Perform device self-test		None			None															
42	Perform master reset																				
43	Set (trim) PV zero																				
44	Write PV units	0		PV units code				As in command													
45	Trim DAC zero	0...3	Measured current (mA)																		
46	Trim DAC gain	0...3		(F)																	
47	Write transfer function	0	Transfer function code																		
48	Read additional device status		Moved to Universal Commands in HART version 7.			See 48 in Universal Commands															
49	Write PV sensor serial number	0...2	Sensor serial number			As in command															
50	Read dynamic variable assignments		None	0	PV transmitter variable code				x												
				1	SV transmitter variable code				x												
				2	TV transmitter variable code				x												
				3	FV transmitter variable code				x												

Table 120 - Common Practice Commands

Command		Data in Command			Data in Reply			Contained in	
No.	Function	Byte	Data	Type ⁽⁶⁾	Byte	Data	Type ⁽⁶⁾	Input Tag	CIP MSG
51	Write dynamic variable assignments	0 1 2 3	PV transmitter variable code SV transmitter variable code TV transmitter variable code FV transmitter variable code			As in command			
52	Set transmitter variable zero	0	Transmitter variable code						
53	Write transmitter variable units		Transmitter variable code						
54	Read transmitter variable information		Transmitter variable code		0 1...3 4 5...8 9...12 13...16	Transmitter variable code Transmitter variable sensor serial Transmitter variable limits units code Transmitter variable upper limit Transmitter variable lower limit Transmitter variable damping value (seconds)	(F) (F) (F)		
55	Write transmitter variable damping value	0 1...4	Transmitter variable code Transmitter variable damping value (seconds)			As in command			
56	Write transmitter variable sensor serial number	0 1...3	Transmitter variable code Transmitter variable sensor			As in command			
57	Read unit tag, description, date		None		0...5 6...17 18...20		(A) (A) (D)		x x x x
58	Write unit tag, descriptor, date	0...5 6...17 18...20	Unit tag (8 characters) Unit descriptor (16 characters) Unit date	(A) (A) (D)					
59	Write number of response preambles	0	Number of response preambles						
60	Read analog output and percent of range	0	Analog output number code		0 1 2...5 6...9	Analog output number code Analog output units code Analog output level Analog output percent of range			
61	Read dynamic variables and PV analog output		None		0 1...4 5 6...9 10 11...14 15 16...19 20 21...24	PV analog output units code PV analog output level PV units code Primary variable SV units code Secondary variable TV units Tertiary variable FV units code Fourth variable	(F) (F) (F) (F) (F) (F)	x x x x x x	x x x x x x

Table 120 - Common Practice Commands

Command		Data in Command			Data in Reply			Contained in			
No.	Function	Byte	Data	Type ⁽⁶⁾	Byte	Data	Type ⁽⁶⁾	Input Tag	CIP MSG		
62	Read analog outputs	0	Analog output number; code for slot 0	0 1 2...5 6		Slot 0 analog output number code Slot 0 Slot 0 level Slot 1 Slot 1 level	(F)				
		1	Analog output number; code for slot 1	7 8...11 12		Slot 1 Slot 1 level Slot 2 Slot 2 level	(F)				
		2	Analog output number; code for slot 2	13 14...17 18		Slot 2 Slot 2 level Slot 3 Slot 3 level ⁽⁸⁾	(F)				
		3 ⁽²⁾	Analog output number; code for slot 3 ⁽⁴⁾	19 20...23			(F)				
63	Read analog output information	0	Analog output number code	0 1 2 3 4...7 8...11 12...15		Analog output number code Analog output alarm select code Analog output transfer function code Analog output range units code Analog output upper-range value Analog output lower-range value Analog output additional damping value (seconds)	(F) (F) (F)				
		0	Analog output number code			As in command					
		1...4	Analog output additional damping value (seconds)								
		0	Analog output number code								
		1	Analog output range units code								
65	Write analog output range value	2...5	Analog output upper-range value	(F)							
		6...9	Analog output lower-range value	(F)							
66	Enter/exit Fixed Analog Output mode	0	Analog output number code								
		1 2...6	Analog output units code Analog output level ⁽⁵⁾							(F)	
67	Trim analog output zero	0	Analog output number code								
		1 2...6	Analog output units code Externally measured analog output level							(F)	
68	Trim analog output gain	0	Analog output number code								
		1 2...6	Analog output units code Externally measured analog output level							(F)	
69	Write analog output transfer function	0	Analog output number code								
		1	Analog output transfer function code								
70	Read analog output endpoint values	0	Analog output number code								
		1 2...5 6...9	Analog output endpoint units code Analog output upper endpoint value Analog output lower endpoint value								

Table 120 - Common Practice Commands

Command		Data in Command			Data in Reply			Contained in	
No.	Function	Byte	Data	Type ⁽⁶⁾	Byte	Data	Type ⁽⁶⁾	Input Tag	CIP MSG
107	Write Burst mode transmitter variables (for command 33)	0 1 2 3	Transmitter variable code for slot 0 Transmitter variable code for slot 1 Transmitter variable code for slot 2 Transmitter variable code for slot 3			As in command			
108	Write Burst mode command number	0	Burst mode command number			As in command			
109	Burst mode control	0	Burst mode control code (0 = exit, 1 = enter)						
110	Read all dynamic variables		None		0 1...4 5 6...9 10 11...14 15 16...19	PV units code PV value SV units code SV value TV units code TV value FV units code FV value	(F) (F) (F) (F)	x x x x x	x x x x x

- (1) 0 = exit Fixed Current mode.
- (2) Truncated after last requested code.
- (3) 0 = burn EEPROM, 1 = copy EEPROM to RAM.
- (4) Truncated after last requested code.
- (5) Not a number exits Fixed-output mode.
- (6) (A) = Packed ASCII, (B) = 3-byte integer, (D) = Date, (F) = Floating Point (HART format), (H) = HART flag
- (7) Truncated after last requested code. Truncated after last requested variable.
- (8) Truncated after last requested level.

HART PV, SV, TV, and FV Status

HART PV, SV, TV, and FV are dynamic variables that contain the values of device variables, which are various direct or indirect process measurements that are performed by the HART field device.

Some devices let a set of their internal device variables be mapped to the PV, SV, TV, FV dynamic variables that are automatically collected in the 1756-IF8H Input Tag.

This mapping is part of the field device configuration, performed via a handheld configurator or asset management system, such as FactoryTalk® AssetCentre or Endress+Hauser FieldCare system.

HART PVStatus, SVStatus, TVStatus, FVStatus are known as Device Variable Status values. These Status values are composed of groups of bits that indicate the quality of the associated device variable.

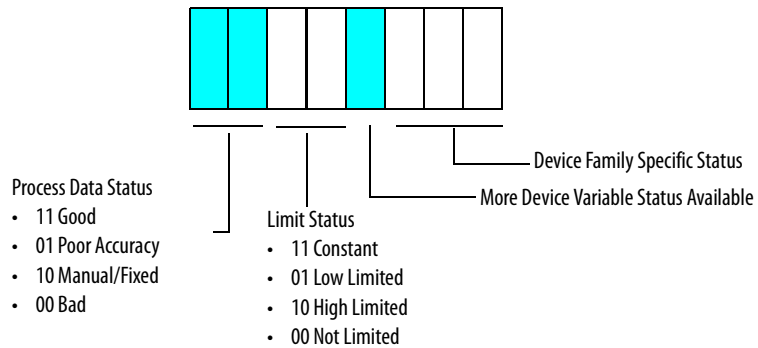

The Limit Status can be used to control windup in PID loops.

Table 121 - HART PV, SV, TV, and FV Status Values

HART PV, SV, TV FV Status Values			Quality		Limit		More Status Available?		Device Family Specific	
Decimal	Hex	Binary							Binary	Decimal
0	0	00000000	00	Bad	00	Not Limited	0	No	000	0
1	1	00000001	00	Bad	00	Not Limited	0	No	001	1
2	2	00000010	00	Bad	00	Not Limited	0	No	010	2
3	3	00000011	00	Bad	00	Not Limited	0	No	011	3
4	4	00000100	00	Bad	00	Not Limited	0	No	100	4
5	5	00000101	00	Bad	00	Not Limited	0	No	101	5
6	6	00000110	00	Bad	00	Not Limited	0	No	110	6
7	7	00000111	00	Bad	00	Not Limited	0	No	111	7
8	8	00001000	00	Bad	00	Not Limited	1	Yes	000	0
9	9	00001001	00	Bad	00	Not Limited	1	Yes	001	1
10	A	00001010	00	Bad	00	Not Limited	1	Yes	010	2
11	B	00001011	00	Bad	00	Not Limited	1	Yes	011	3
12	C	00001100	00	Bad	00	Not Limited	1	Yes	100	4
13	D	00001101	00	Bad	00	Not Limited	1	Yes	101	5
14	E	00001110	00	Bad	00	Not Limited	1	Yes	110	6
15	F	00001111	00	Bad	00	Not Limited	1	Yes	111	7
16	10	00010000	00	Bad	01	Low Limited	0	No	000	0
17	11	00010001	00	Bad	01	Low Limited	0	No	001	1
18	12	00010010	00	Bad	01	Low Limited	0	No	010	2
19	13	00010011	00	Bad	01	Low Limited	0	No	011	3
20	14	00010100	00	Bad	01	Low Limited	0	No	100	4
21	15	00010101	00	Bad	01	Low Limited	0	No	101	5
22	16	00010110	00	Bad	01	Low Limited	0	No	110	6
23	17	00010111	00	Bad	01	Low Limited	0	No	111	7

Table 121 - HART PV, SV, TV, and FV Status Values (continued)

HART PV, SV, TV FV Status Values			Quality		Limit		More Status Available?		Device Family Specific	
Decimal	Hex	Binary							Binary	Decimal
24	18	00011000	00	Bad	01	Low Limited	1	Yes	000	0
25	19	00011001	00	Bad	01	Low Limited	1	Yes	001	1
26	1A	00011010	00	Bad	01	Low Limited	1	Yes	010	2
27	1B	00011011	00	Bad	01	Low Limited	1	Yes	011	3
28	1C	00011100	00	Bad	01	Low Limited	1	Yes	100	4
29	1D	00011101	00	Bad	01	Low Limited	1	Yes	101	5
30	1E	00011110	00	Bad	01	Low Limited	1	Yes	110	6
31	1F	00011111	00	Bad	01	Low Limited	1	Yes	111	7
32	20	00100000	00	Bad	10	High Limited	0	No	000	0
33	21	00100001	00	Bad	10	High Limited	0	No	001	1
34	22	00100010	00	Bad	10	High Limited	0	No	010	2
35	23	00100011	00	Bad	10	High Limited	0	No	011	3
36	24	00100100	00	Bad	10	High Limited	0	No	100	4
37	25	00100101	00	Bad	10	High Limited	0	No	101	5
38	26	00100110	00	Bad	10	High Limited	0	No	110	6
39	27	00100111	00	Bad	10	High Limited	0	No	111	7
40	28	00101000	00	Bad	10	High Limited	1	Yes	000	0
41	29	00101001	00	Bad	10	High Limited	1	Yes	001	1
42	2A	00101010	00	Bad	10	High Limited	1	Yes	010	2
43	2B	00101011	00	Bad	10	High Limited	1	Yes	011	3
44	2C	00101100	00	Bad	10	High Limited	1	Yes	100	4
45	2D	00101101	00	Bad	10	High Limited	1	Yes	101	5

This Device Variable Status byte is a new HART feature in HART protocol revision 6 and many HART devices do not yet support it. For those devices, the module creates a status value that is based on the communication status of the device.

If the PV, SV, TV, FV are being collected without communication errors, the value is set to 16#C0, which indicates Good, Not Limited. Otherwise, the value is set to 0, which indicates Bad, Not Limited, no specific information available.

Manufacturer Identification Codes

This appendix identifies the manufacturer with their assigned code.

Decimal	Hex	Company Name
1	01	Acromag
2	02	Allen-Bradley
3	03	Ametek
4	04	Analog Devices
5	05	ABB
6	06	Beckman
7	07	Bell Microsenser
8	08	Bourns
9	09	Bristol Babcock
10	0A	Brooks Instrument
11	0B	Chessell
12	0C	Combustion Engineering
13	0D	Daniel Industries
14	0E	Delta
15	0F	Dieterich Standard
16	10	Dohrmann
17	11	Endress+Hauser
18	12	ABB
19	13	Fisher Controls
20	14	Foxboro
21	15	Fuji
22	16	ABB
23	17	Honeywell
24	18	ITT Barton
25	19	Thermo MeasureTech
26	1A	ABB
27	1B	Leeds & Northup
28	1C	Leslie
29	1D	M-System Co.
30	1E	Measurex
31	1F	Micro Motion
32	20	Moore Industries

Decimal	Hex	Company Name
33	21	PRIME Measurement Products
34	22	Ohkura Electric
35	23	Paine
36	24	Rochester Instrument Systems
37	25	Ronan
38	26	Rosemount
39	27	Peek Measurement
40	28	Actaris Neptune
41	29	Sensall
42	2A	Siemens
43	2B	Weed
44	2C	Toshiba
45	2D	Transmation
46	2E	Rosemount Analytic
47	2F	Metso Automation
48	30	Flowserve
49	31	Varec
50	32	Viatran
51	33	Delta/Weed
52	34	Westinghouse
53	35	Xomox
54	36	Yamatake
55	37	Yokogawa
56	38	Nuovo Pignone
57	39	Promac
58	3A	Exac Corporation
59	3B	Mobrey
60	3C	Arcom Control System
61	3D	Princo
62	3E	Smar
63	3F	Foxboro Eckardt
64	40	Measurement Technology
65	41	Applied System Technologies
66	42	Samson
67	43	Sparling Instruments
68	44	Fireye
69	45	Krohne
70	46	Betz
71	47	Druck
72	48	SOR

Decimal	Hex	Company Name
73	49	Elcon Instruments
74	4A	EMCO
75	4B	Termiflex Corporation
76	4C	VAF Instruments
77	4D	Westlock Controls
78	4E	Drexelbrook
79	4F	Saab Tank Control
80	50	K-TEK
81	51	SENSIDYNE, INC
82	52	Draeger
83	53	Raytek
84	54	Siemens Milltronics PI
85	55	BTG
86	56	Magnetrol
87	58	Metso Automation
88	59	Siemens Milltronics PI
89	59	HELIOS
90	5A	Anderson Instrument Company
91	5B	INOR
92	5C	ROBERTSHAW
93	5D	PEPPERL+FUCHS
94	5E	ACCUTECH
95	5F	Flow Measurement
96	60	Courdon-Haenni
97	61	Knick
98	62	VEGA
99	63	MTS Systems Corp.
100	64	Oval
101	65	Masoneilan-Dresser
102	66	BESTA
103	67	Ohmart
104	68	Harold Beck and Sons
105	69	rittmeyer instrumentation
106	6A	Rossel Messtechnik
107	6B	WIKA
108	6C	Bopp & Reuther Heinrichs
109	6D	PR Electronics
110	6E	Jordan Controls
111	6F	Valcom s.r.l.
112	70	US ELECTRIC MOTORS

Decimal	Hex	Company Name
113	71	Apparatebau Hundsbach
114	72	Dynisco
115	73	Spriano
116	74	Direct Measurement
117	75	Klay Instruments
118	76	CiDRA CORP.
119	77	MMG AM DTR
120	78	Buerkert Fluid Control Systems
121	79	AALIAN Process Mgt
122	7A	PONDUS INSTRUMENTS
123	7B	ZAP S.A. Ostrow Wielkopolski
124	7C	GLI
125	7D	Fisher-Rosemount Performance Technologies
126	7E	Paper Machine Components
127	7F	LABOM
128	80	Danfoss
129	81	Turbo
130	82	TOKYO KEISO
131	83	SMC
132	84	Status Instruments
133	85	Huakong
134	86	Duon System
135	87	Vortek Instruments, LLC
136	88	AG Crosby
137	89	Action Instruments
138	8A	Keystone Controls
139	8B	Thermo Electronic Co.
140	8C	ISE Magtech
141	8D	Rueger
142	8E	Mettler Toledo
143	8F	Det-Tronics
144	90	Thermo MeasureTech
145	91	DeZURIK
146	92	Phase Dynamics
147	93	WELLTECH SHANGHAI
148	94	ENRAF
149	95	4tech ASA
150	96	Brandt Instruments
151	97	Nivelco
152	98	Camille Bauer

Decimal	Hex	Company Name
153	99	Metran
154	9A	Milton Roy Co.
155	9B	PMV
156	9C	Turck
157	9D	Panametrics
158	9E	R. Stahl
159	9F	Analytical Technologies Inc.
160	A0	FINT
161	A1	BERTHOLD
162	A2	InterCorr
163	A3	China BRICONTE Co Ltd
164	A4	Electron Machine
165	A5	Sierra Instruments
166	A6	Fluid Components Intl
167	A7	Solid AT
168	A8	Meriam Instrument
169	A9	Invensys
170	AA	S-Products
171	AB	Tyco Valves & Controls
172	AC	Micro Matic Instrument A/S
173	AD	J-Tec Associates
174	AE	TRACERCO
175	AF	AGAR
176	B0	Phoenix Contact
177	B1	Andean Instruments
178	B2	American Level Instrument
179	B3	Hawk
180	B4	YTC
181	B5	Pyromation Inc.
182	B6	Satron Instruments
183	B7	BIFFI
184	B8	SAIC
185	B9	BD Sensors
186	BA	Andean Instruments
187	BB	Kemotron
188	BC	APLISENS
189	BD	Badger Meter
190	BE	HIMA
191	BF	GP:50
192	C0	Kongsberg Maritime

Decimal	Hex	Company Name
193	C1	ASA S.p.A.
194	C2	Hengesbach
195	C3	Lanlian Instruments
196	C4	Spectrum Controls
197	C5	Kajaani Process Measurements
198	C6	FAFNIR
199	C7	SICK-MAIHAK
200	C8	JSP Nova Paka
201	C9	MESACON
202	CA	Spirax Sarco Italy
203	CB	L&J TECHNOLOGIES
204	CC	Tecfluid S.A.
205	CD	Sailsors Instruments
206	CE	Roost
207	CF	KOSO
208	D0	MJK
209	D1	GE Energy
210	D2	BW Technologies
211	D3	HEINRICHS
212	D4	SIC
213	D5	HACH LANGE
214	D6	Exalon Instruments
215	D7	FAURE HERMAN
216	D8	STI S.r.l.
217	D9	Manometr-Kharkiv
218	DA	Dalian-Instruments
219	DB	Spextrex
220	DC	SIPAI Instruments
221	DD	Advanced Flow
222	DE	Rexa. Koso America
223	DF	General Monitors, Inc.
224	E0	Manufacturer Expansion
249	F9	HART Communication Foundation
24576	6000	ExSaf
24577	6001	SEOJIN INSTECH
24578	6002	TASI FLOW
24579	6003	Daihan Control
24580	6004	APM
24581	6005	ORANGE INSTRUMENTS. UK
24582	6006	BARTEC

Decimal	Hex	Company Name
24583	6007	Detcon
24584	6008	MSA
24585	6009	METROVAL
24586	600A	Etalon Rus
24587	600B	JOGLER
24588	600C	KSB
24589	600D	Richter CT
24590	600E	NET SAFETY
24591	600F	SECanada
24592	6010	SUPCON
24593	6011	DKK - TOA
24594	6012	Dwyer Instruments
24595	6013	FineTek
24596	6014	Top Worx Inc.
24597	6015	Hoffer Flow Controls
24598	6016	Dust Networks
24599	6017	Forbes Marshall
24600	6018	All Measures, Ltd.
24601	6019	MACTek
24602	601A	CSI
24603	601B	TC Fluid Control
24604	601C	Rohrback Cosasco
24605	601D	AirSprite
24606	601E	Microcyber Inc.
24607	601F	TIG
24608	6020	ifm prover Gmbh
24609	6021	FLEXIM
24610	6022	TOKIMEC.INC
24611	6023	SBEM
24612	6023	SkoFlo Industries, Inc.
24613	6024	StoneL Corporation
24614	6026	EUREKA FLOW
24615	6027	BEKA associates
24616	6028	Capstar Automation
24617	6029	Pulsar
24618	602A	Elemer
24619	602B	Soft Tech Group

Notes:

Engineering Unit Code Numbers

Code Number Details

This table maps engineering unit code numbers to their meaning and abbreviations. These codes are used in the process variable range display.

Unit Codes	Description from HART Specification	Abbreviated Units
1	inches of water at 20 °C (68 °F)	inH2O (20 °C or 68 °F)
2	inches of mercury at 0 °C (32 °F)	inHg (0 °C or 32 °F)
3	feet of water at 20 °C (68 °F)	ftH2O (20 °C or 68 °F)
4	millimeters of water at 20 °C (68 °F)	mmH2O (20 °C or 68 °F)
5	millimeters of mercury at 0 °C (32 °F)	mmHg (0 °C or 32 °F)
6	pounds per square inch	psi
7	bars	bar
8	millibars	mbar
9	grams per square centimeter	g/square cm
10	kilograms per square centimeter	kg/square cm
11	pascals	Pa
12	kilopascals	kPa
13	torr	torr
14	atmospheres	atm
15	cubic feet per minute	cubic ft/min
16	gallons per minute	usg/min
17	liters per minute	L/min
18	imperial gallons per minute	impgal/min
19	cubic meter per hour	cubic m/h
20	feet per second	ft/s
21	meters per second	m/s
22	gallons per second	usg/s
23	million gallons per day	million usg/d
24	liters per second	L/s
25	million liters per day	ML/day
26	cubic feet per second	cubic ft/s
27	cubic feet per day	cubic ft/d
28	cubic meters per second	cubic m/s
29	cubic meters per day	cubic m/d
30	imperial gallons per hour	impgal/h
31	imperial gallons per day	impgal/d

Unit Codes	Description from HART Specification	Abbreviated Units
32	Degrees Celsius	°C
33	Degrees Fahrenheit	°F
34	Degrees Rankine	°R
35	Kelvin	°K
36	millivolts	mV
37	ohms	ohm
38	hertz	hz
39	milliamperes	mA
40	gallons	usg
41	liters	L
42	imperial gallons	impgal
43	cubic meters	cubic m
44	feet	ft
45	meters	m
46	barrels	bbl
47	inches	in
48	centimeters	cm
49	millimeters	mm
50	minutes	min
51	seconds	s
52	hours	h
53	days	d
54	centistokes	centistokes
55	centipoise	cP
56	microsiemens	microsiemens
57	percent	%
58	volts	V
59	pH	pH
60	grams	g
61	kilograms	kg
62	metric tons	t
63	pounds	lb
64	short tons	short ton
65	long tons	long ton
66	milli siemens per centimeter	millisiemens/cm
67	micro siemens per centimeter	microsiemens/cm
68	newton	N
69	newton meter	N m
70	grams per second	g/s
71	grams per minute	g/min

Unit Codes	Description from HART Specification	Abbreviated Units
72	grams per hour	g/h
73	kilograms per second	kg/s
74	kilograms per minute	kg/min
75	kilograms per hour	kg/h
76	kilograms per day	kg/d
77	metric tons per minute	t/min
78	metric tons per hour	t/h
79	metric tons per day	t/d
80	pounds per second	lb/s
81	pounds per minute	lb/min
82	pounds per hour	lb/h
83	pounds per day	lb/d
84	short tons per minute	short ton/min
85	short tons per hour	short ton/h
86	short tons per day	short ton/d
87	long tons per hour	long ton/h
88	long tons per day	long ton/d
89	deka therm	Dth
90	specific gravity units	specific gravity units
91	grams per cubic centimeter	g/cubic cm
92	kilograms per cubic meter	kg/cubic m
93	pounds per gallon	lb/usg
94	pounds per cubic feet	lb/cubic ft
95	grams per milliliter	g/mL
96	kilograms per liter	kg/L
97	grams per liter	g/L
98	pounds per cubic inch	lb/cubic in
99	short tons per cubic yard	short ton/cubic yd
100	degrees twaddell	°Tw
101	degrees brix	°Bx
102	degrees baume heavy	BH
103	degrees baume light	BL
104	degrees API	°API
105	percent solids per weight	% solid/weight
106	percent solids per volume	% solid/volume
107	degrees balling	degrees balling
108	proof per volume	proof/volume
109	proof per mass	proof/mass
110	bushels	bushel
111	cubic yards	cubic yd

Unit Codes	Description from HART Specification	Abbreviated Units
112	cubic feet	cubic ft
113	cubic inches	cubic in
114	inches per second	in/s
115	inches per minute	in/min
116	feet per minute	ft/min
117	degrees per second	°/s
118	revolutions per second	rev/s
119	revolutions per minute	rpm
120	meters per hour	m/hr
121	normal cubic meter per hour	normal cubic m/h
122	normal liter per hour	normal L/h
123	standard cubic feet per minute	standard cubic ft/min
124	bbl liq	bbl liq
125	ounce	oz
126	foot pound force	ft lb force
127	kilo watt	kW
128	kilo watt hour	kW h
129	horsepower	hp
130	cubic feet per hour	cubic ft/h
131	cubic meters per minute	cubic m/min
132	barrels per second	bbl/s
133	barrels per minute	bbl/min
134	barrels per hour	bbl/h
135	barrels per day	bbl/d
136	gallons per hour	usg/h
137	imperial gallons per second	impgal/s
138	liters per hour	L/h
139	parts per million	ppm
140	mega calorie per hour	Mcal/h
141	mega joule per hour	MJ/h
142	british thermal unit per hour	BTU/h
143	degrees	degrees
144	radian	rad
145	inches of water at 15.6 °C (60 °F)	inH2O (15.6 °C or 60 °F)
146	micrograms per liter	micrograms/L
147	micrograms per cubic meter	micrograms/cubic m
148	percent consistency	% consistency
149	volume percent	volume %
150	percent steam quality	% steam quality
151	feet in sixteenths	ft in sixteenths

Unit Codes	Description from HART Specification	Abbreviated Units
152	cubic feet per pound	cubic ft/lb
153	picofarads	pF
154	milliliters per liter	mL/L
155	microliters per liter	microliters/L
156	percent plato	% plato
157	percent lower explosion level	% lower explosion level
158	mega calorie	Mcal
159	Kohms	kohm
160	mega joule	MJ
161	british thermal unit	BTU
162	normal cubic meter	normal cubic m
163	normal liter	normal L
164	standard cubic feet	normal cubic ft
165	parts per billion	parts/billion
235	gallons per day	usg/d
236	hectoliters	hL
237	megapascals	MPa
238	inches of water at 4 °C (39.2 °F)	inH2O (4 °C or 39.2 °F)
239	millimeters of water at 4 °C (39.2 °F)	mmH2O (4 °C or 39.2 °F)

Notes:

The following terms and abbreviations are used throughout this manual. For definitions of terms that are not listed here, refer to the Allen-Bradley Industrial Automation Glossary, publication [AG-7.1](#).

- balanced circuit** 1) A circuit whose two sides are electrically alike and symmetrical to a common reference point, usually ground. 2) Contrasted with **unbalanced circuit** ([page 255](#)).
- broadcast** Data transmissions to all addresses.
- CIP** Acronym for Common Industrial Protocol; a communication protocol, or language, between industrial devices. CIP provides seamless communication for devices on DeviceNet, ControlNet, and EtherNet/IP networks.
- compatible match** An Electronic Keying Protection mode that requires the physical module and the module that is configured in the software to match according to vendor, catalog number, and major revision. The minor revision of the module must be greater than or equal to that configured.
- connection** The continuous communication mechanism from the controller to an I/O module in the control system.
- ControlBus** The backplane that is used by the 1756 chassis.
- coordinated system time (CST)** Timer value, which is kept synchronized for all modules within one ControlBus™ chassis. The CST is a 64-bit number with microsecond resolution.
- differential** 1) Pertaining to a method of signal transmission through two wires. The transmission always has opposite states. The signal data is the polarity difference between the wires; when one is high, the other is low. Neither wire is grounded. The circuit can be either a balanced circuit, a floating circuit, or a circuit with a high-impedance path to ground from either end. Used regarding encoders, analog I/O circuits, and communication circuits. 2) Contrasted with **single-ended** ([page 255](#)).
- direct connection** An I/O connection, where the controller establishes an individual connection with I/O modules.
- disable keying** An option that turns off all electronic keying to the module. Requires no attributes of the physical module and the module that is configured in the software to match. A connection is attempted to the module even if it is the wrong type.
- download** The process of transferring the contents of a project on the workstation into the controller.
- electronic keying** A system feature that makes sure that physical module attributes are consistent with what was configured in software.

- exact match** An Electronic Keying Protection mode that requires the physical module and the module that is configured in the software to match identically, according to vendor, catalog number, major revision, and minor revision.
- field side** Interface between user field wiring and I/O module. In this glossary, see related entry for system side.
- flash update** The process of updating the firmware of the module.
- fourth value (FV)** Also abbreviated as QV for quaternary value, this dynamic variable contains the fourth value of Device Variables, which are direct or indirect process measurements by a HART field device.
- frequency shift keying** A method of using frequency modulation to send digital information that is used by HART field devices.
- Hard Run mode** Mode where keyswitch of controller is in Run position.
- HART** Acronym for highway addressable remote transducer.
- inhibit** A ControlLogix® process that lets you configure an I/O module, but prevent it from communicating with the owner-controller. In this case, the controller does not establish a connection.
- Input Data format** Format that defines the type of information that is transferred between an I/O module and its owner-controller. This format also defines the tags that are created for each I/O module.
- interface module (IFM)** A pre-wired removable terminal block (RTB).
- listen-only connection** An I/O connection that lets a controller monitor I/O module data without owning the module, sending it a configuration, or controlling its outputs.
- major revision** A module revision that is updated any time there is a functional change to the module, and results in an interface change with software.
- minor revision** A module revision that is updated any time there is a change to the module that does not affect its function or software user interface.
- multicast** Data transmissions that reach a specific group of one or more destinations.
- multiple owners** A configuration setup where multiple owner-controllers use the same configuration information to simultaneously own an input module.
- network update time (NUT)** The smallest repetitive time interval in which the data can be sent on a ControlNet network. The NUT can be configured over the range from 2...100 ms using RSNetWorx™ software.
- owner-controller** The controller that creates and stores the primary configuration and communication connection to a module.

primary value (PV)	Dynamic variable that contains the primary value of Device Variables, which are direct or indirect process measurements by a HART field device. See page 16 for more information.
Program mode	In this mode, the controller program is not executing. Inputs are actively producing data. Outputs are not actively controlled and go to their configured Program mode state.
remote connection	An I/O connection where the controller establishes an individual connection with I/O modules in a remote chassis.
removable terminal block (RTB)	Field wiring connector for I/O modules.
removal and insertion under power (RIUP)	ControlLogix feature that lets you install or remove a module or RTB while power is applied.
requested packet interval (RPI)	A configurable parameter that defines when the module will multicast data.
Run mode	In this mode, the controller program is executing. Inputs are actively producing data. Outputs are actively controlled.
secondary value (SV)	Dynamic variable that contains the secondary value of Device Variables, which are direct or indirect process measurements by a HART field device.
service	A system feature that is performed on user demand.
single-ended	1) Unbalanced, as when one side is grounded. See unbalanced circuit (page 255) 2) Contrasted with differential (page 253).
system side	Backplane side of the interface to the I/O module. In this glossary, see related entry for field side.
tag	A named area of the memory of the controller where data is stored like a variable.
third value (TV)	Dynamic variable that contains the tertiary, or third, value of Device Variables, which are direct or indirect process measurements by a HART field device.
timestamping	ControlLogix process that stamps a change in input, output, or diagnostic data with a time reference that indicates when that change occurred.
unbalanced circuit	1) A circuit whose two sides are electrically dissimilar, as when one side is grounded. 2) Contrasted with balanced circuit (page 253).

Notes:

Numerics

1756-IF16H module

- analog and HART by channel tags 89
- analog and HART PV tags 88
- analog only tags 87
- channel faults 85
- configuration tags 86
- data formats 75
- fault reporting 83, 99
- features 75
- input channel ranges 76
- input tags, analog and HART by channel 89
- input tags, analog and HART PV 88
- input tags, analog only 87
- wiring diagram 80

1756-IF16IH module

- channel faults 100
- configuration tags 102
 - Configure HART Device = No 102
- data formats 91, 93
- fault reporting 99
- features 91
- input channel ranges 93
- input tags, analog and HART by channel 105
- input tags, analog and HART PV 104
- input tags, analog only 103
- Set Device Info 168
- wiring diagram 97

1756-IF8H module

- analog and HART by channel tags 51
- analog and HART PV tags 49
- analog only tags 48
- configuration tags 47
- data formats 33
- features 33
- input channel ranges 34
- input tags, analog and HART PV 49
- input tags, analog only 48
- wiring diagram 40

1756-IF8IH module

- analog and HART by channel tags 72
- auto-configure HART device 59
- channel faults 63
- configuration tags
 - Configure HART Device = No 65
 - Configure HART Device = Yes 66
- data formats 53, 55
- fault reporting 62
- features 53, 91
- filter
 - digital 57
- HART compatibility 54
- input channel ranges 55
- input ranges 53
- input tags, analog and HART by channel
 - Configure HART Device = No 70
 - Configure HART Device = Yes 72
- input tags, analog and HART PV 68
- input tags, analog only 67
- isolation 53
- output tags, analog and HART by channel

- Configure HART Device = Yes 74

- process alarms 60
- Set Device Info 168
- wiring diagram 61

1756-OF8H module

- analog and HART by channel tags 121
- analog and HART PV tags 119
- analog only tags 118
- configuration tags 117
- data formats 107
- fault reporting 113
- features 107
- input tags
 - analog and HART PV 138
- input tags, analog only 118
- output tags 122
- wiring diagram 111

1756OF8H module

- input tags, analog and HART PV 119

1756-OF8IH module

- auto-configure HART device 127
- channel faults 131
- configuration tags
 - Configure HART Device = No 134
 - Configure HART Device = Yes 136
- data formats 123
- fault mode output state 125
- fault reporting 129
- features 123
- input tags
 - analog only 137
- input tags, analog and HART by channel
 - Configure HART Device = No 139
 - Configure HART Device = Yes 141
- input tags, analog and HART PV 138
- input tags, analog only 137
- module faults 131
- output tags
 - Configure HART Device = No 143
 - Configure HART Device = Yes 143
- powerup state 125
- Set Device Info 168
- wiring diagram 128
- write HART variables 127

A

alarm

- 1756-IF8H tab 158
- clamp limit 110, 127
- deadband 38
- process 38
- rate 39, 59

alarm deadband 60

all channels

- configuration 156
- output configuration 161

asset management

- HART modules 199
- software 19

assignment

- dynamic variable 173

auto-configure HART device 59

C

calibration tab 170

channel

- configuration 152
- input status 46, 85, 101
- output status 116, 132

channel faults

- 1756-IF16H module 85
- 1756-IF16IH module 100
- 1756-IF8IH module 63
- 1756-OF8IH module 131

CIP messaging

- HART data 177
- pass-through HART data 187

circuit

- input diagram
 - 1756-IF16H module 82, 98
 - 1756-IF8IH module 42
 - 1756-IF8IH module 61
- output diagram
 - 1756-OF8IH module 112
 - 1756-OF8IH module 128

clamp limit

- alarm 110, 127
- output module 110, 126

command 3 or 9

- dynamic variable assignment 173

communication

- fault 163
- HART 17
- unicast 32

components

- module 14

configuration

- all channels 156
- all output channels 161
- channel 152
- configuration tab for input modules 151
- HART devices 148
- input channels 160
- module 145
- output tab 160

connection 253

- direct connection 253
- direct connections 22
- listen-only 30
- tab 149

controller

- HART 13

ControlNet network 26, 29 . . . 30

coordinated system time (CST) 150, 253

create a module 145

D

data

- collection 174
- echo
 - output modules 111, 127
- formats
 - 1756-IF16H module 75
 - 1756-IF16IH module 93

- 1756-IF8IH module 55
- 1756-OF8IH 124
 - input module 34, 76
 - output module 108
- input tag 170
- tags
 - 1756-116IH module 101
 - 1756-IF8H module 46, 86, 117
 - 1756-IF8IH module 65
 - 1756-OF8IH module 134

Data Echo 127

data formats

- 1756-IF16IH module 91
- 1756-IF8H module 33
- 1756-IF8IH module 53
- 1756-OF8H module 107
- 1756-OF8IH module 123

detection

- open circuit 58
- open wire 110, 126
- underrange and overrange 36, 58, 78, 96
- wire-off 80

digital

- filter 37
- filter 79

direct connection 22, 253

dynamic variable assignment 173

E

electronic keying 20, 253

- compatible match 253
- disable keying 253
- exact match 254

engineering unit

- code numbers 247
- scaling 153

EtherNet/IP network 27, 30

event tasks 25

F

fault

- codes 221
- communication 163
- reporting
 - 1756-IF16IH module 99
 - 1756-IF8H module 43
 - 1756-IF8IH module 62
 - 1756-OF8IH 129

fault mode output state

- 1756-OF8IH 125

features

- 1756-IF16H module 75
- 1756-IF16IH module 91
- 1756-IF8H module 33
- 1756-IF8IH module 53, 91
- 1756-OF8H module 107
- 1756-OF8IH module 123

filter

- channel ADC 56, 93
- digital 37, 79

1756-IF8IH module 57
 input module 77
 module 35
fourth value definition 18

G

general tab 147
glossary of terms 253

H

HART
 additional protocol information 227
 communication 17
 data via MSG instructions 177
 definition 254
 device
 auto-configuration 127
 configuration 148
 device information tab 165
 getting data over CIP MSG 177
 integrated networks 18
 Logix controller 13
 protocol 17
 variables 171
 writing variables 127
HART command tab 169
HART compatibility
 1756-IF8IH module 54
hold
 initialization 109, 126

I

inhibit module 254
initialization
 hold 109, 126
input
 circuit diagram
 1756-IF16H module 82
 1756-IF8IH module, current 42
 1756-IF8IH module, voltage 43
 1756-IF8IH module 61
 error codes 222, 223
 module
 channel ranges 34
 channel status 46, 85, 101
 data formats 34, 76
 filter 77
 local chassis 23
 multiple owners 31
 operation 22
 real time sample 36, 58, 96
 remote chassis 26
 tag data 170
input ranges
 1756-IF16H module 76
 1756-IF16IH module 93
 1756-IF8IH module 53, 55
input tags
 analog and HART by channel
 Configure HART Device = No 105

isolation
 1756-IF8IH module 53

K

keying
 electronic 20
 RTB 16

L

ladder logic
 message configuration 206
 message instructions 203
 unlatch alarms (1756-IF6I module) 210
 unlatch alarms (1756-OF6VI module) 212
limits tab 164
listen-only connection 30
local chassis
 input module 23
 output module 28

M

major revision 254
manufacturer ID codes 239
minor revision 254
module
 accessories 15
 components 14
 configuration 145
 creation 145
 data collection 174
 filter 35
 channel ADC filter 56, 93
 keying 20
 operation 21
 refresh 150
 removal 224
 resolution 157
 scaling 19
 status 150
 tab 149
 troubleshooting 215
module faults
 1756-OF8IH module 131

N

network update time (NUT)
 for ControlNet network 254

O

open circuit detection 58
open wire detection 110, 126
operation
 input module 22
 module 21
 output 28

output

- 1756-OF8IH
 - data formats 124
- circuit diagram
 - 1756-OF8H module 112
 - 1756-OF8IH module 128
- data echo 28
- error codes 223
- module
 - channel status 116, 132
 - circuit diagrams 112
 - clamp limit 110, 126
 - data formats 108
 - local chassis 28
 - ramp rate 162
 - ramp/rate 109, 125
 - remote chassis 29
 - resolution 108
 - wiring 111
- operation 28
- state
 - module tab 162

overrange

- detection 36, 58, 78, 96

ownership

- changing configuration in multiple owner-controllers 32
- multiple owners 31, 32, 254
- owner-controller 254

P

- pass-through messages** 177, 187, 189, 191, 194, 216, 217

power supply

- input wiring 41
- wiring 81

powerup state

- 1756-OF8IH module 125

primary value definition 18**process alarms** 60**protocol**

- HART 17

R**ramp rate limit**

- output module 109, 125, 162

rate alarm 59**real time sample (RTS)** 23, 36, 58, 78, 96

- in a local chassis 23
- in a remote chassis 26

refresh module 150**remote chassis**

- connecting via ControlNet network 26, 29
 - ... 30
- connecting via EtherNet/IP network 27, 30
- input module 26
- output module 29

remove

- and insert under power (RIUP) 255
- module 224

requested packet interval (RPI) 24, 255

- local chassis 23

resolution

- module 157
- output module 108

revision

- major 254
- minor 254

RPI 23, 24**RTB keying** 16**RTS. See real time sample****S****scaling**

- engineering units 153
- module 19

secondary value definition 18**Set Device Info** 168**software**

- asset management 19

status

- module 150

T**tab**

- 1756-IF8H alarm 158
- connection 149
- general 147
- HART device information 165
- input configuration 151
- module 149
- output configuration 160
- output limits 164
- output state 162

tasks

- event 25

third value definition 18**timestamp** 19**triggering event tasks** 25**troubleshooting**

- module 215

U**underrange**

- detection 36, 58, 78, 96

unicast

- communication 32
- connection 149

unlatch alarms 209**V****variables**

- HART 171

W**wire-off detection** 80**wiring**

- analog interface modules (AIFM) 225
- input diagrams 40, 80, 97
- output module 111
- power supply 41, 81
- pre-wired cables 225

wiring diagram

- 1756-IF16H module 80
- 1756-IF16IH module 97
- 1756-IF8H module 40
- 1756-IF8IH module 61
- 1756-OF8H module 111
- 1756-OF8IH module 128

Notes:

Rockwell Automation Support

Use the following resources to access support information.

Technical Support Center	Knowledgebase Articles, How-to Videos, FAQs, Chat, User Forums, and Product Notification Updates.	https://rockwellautomation.custhelp.com/
Local Technical Support Phone Numbers	Locate the phone number for your country.	http://www.rockwellautomation.com/global/support/get-support-now.page
Direct Dial Codes	Find the Direct Dial Code for your product. Use the code to route your call directly to a technical support engineer.	http://www.rockwellautomation.com/global/support/direct-dial.page
Literature Library	Installation Instructions, Manuals, Brochures, and Technical Data.	http://www.rockwellautomation.com/global/literature-library/overview.page
Product Compatibility and Download Center (PCDC)	Get help determining how products interact, check features and capabilities, and find associated firmware.	http://www.rockwellautomation.com/global/support/pcdc.page

Documentation Feedback

Your comments will help us serve your documentation needs better. If you have any suggestions on how to improve this document, complete the How Are We Doing? form at http://literature.rockwellautomation.com/idc/groups/literature/documents/du/ra-du002_-en-e.pdf.

Rockwell Automation maintains current product environmental information on its website at <http://www.rockwellautomation.com/rockwellautomation/about-us/sustainability-ethics/product-environmental-compliance.page>.

Allen-Bradley, ControlBus, ControlFLASH, ControlLogix, FactoryTalk, Logix5000, Rockwell Automation, Rockwell Software, RSLinx, RSLogix 5000, RSNetWorx, Studio 5000, and Studio 5000 Logix Designer are trademarks of Rockwell Automation, Inc.

Rockwell Otomasyon Ticaret A.Ş., Kar Plaza İş Merkezi E Blok Kat:6 34752 İçerenköy, İstanbul, Tel: +90 (216) 5698400

www.rockwellautomation.com

Power, Control and Information Solutions Headquarters

Americas: Rockwell Automation, 1201 South Second Street, Milwaukee, WI 53204-2496 USA, Tel: (1) 414.382.2000, Fax: (1) 414.382.4444

Europe/Middle East/Africa: Rockwell Automation NV, Pegasus Park, De Kleetlaan 12a, 1831 Diegem, Belgium, Tel: (32) 2 663 0600, Fax: (32) 2 663 0640

Asia Pacific: Rockwell Automation, Level 14, Core F, Cyberport 3, 100 Cyberport Road, Hong Kong, Tel: (852) 2887 4788, Fax: (852) 2508 1846

Publication 1756-UM533E-EN-P - November 2016

Supersedes Publication 1756-UM533D-EN-P - January 2015

Copyright © 2016 Rockwell Automation, Inc. All rights reserved. Printed in the U.S.A.