



Allen-Bradley

1395 Digital DC Drive

Troubleshooting Guide

**Rockwell
Automation**

Important User Information

Solid state equipment has operational characteristics differing from those of electromechanical equipment. “*Safety Guidelines for the Application, Installation and Maintenance of Solid State Controls*” (Publication SGI-1.1 available from your local Rockwell Automation Sales Office or online at <http://www.ab.com/manuals/gi>) describes some important differences between solid state equipment and hard-wired electromechanical devices. Because of this difference, and also because of the wide variety of uses for solid state equipment, all persons responsible for applying this equipment must satisfy themselves that each intended application of this equipment is acceptable.

In no event will Rockwell Automation, Inc. be responsible or liable for indirect or consequential damages resulting from the use or application of this equipment.

The examples and diagrams in this manual are included solely for illustrative purposes. Because of the many variables and requirements associated with any particular installation, Rockwell Automation, Inc. cannot assume responsibility or liability for actual use based on the examples and diagrams.

No patent liability is assumed by Rockwell Automation, Inc. with respect to use of information, circuits, equipment, or software described in this manual.

Reproduction of the contents of this manual, in whole or in part, without written permission of Rockwell Automation, Inc. is prohibited.

Throughout this manual we use notes to make you aware of safety considerations.



ATTENTION: Identifies information about practices or circumstances that can lead to personal injury or death, property damage, or economic loss.

Attentions help you:

- identify a hazard
- avoid the hazard
- recognize the consequences

Important: Identifies information that is especially important for successful application and understanding of the product.



Shock Hazard labels may be located on or inside the drive to alert people that dangerous voltage may be present.

Chapter 1	Understanding the Basic Principles	
	General	1-1
	Required Equipment	1-1
	ESD Sensitivity Precaution	1-2
	Safety Facts to Read Before Proceeding	1-3
 Chapter 2	 Malfunctions with Indications	
	General	2-1
	Hard Faults	2-1
	Soft Faults	2-2
	Warning Faults	2-2
	Fault Response Selection	2-2
	Fault Setup Parameters	2-4
	Fault Status Indicators	2-5
	Bulletin 1300 Programming Terminal	2-7
	Fault Descriptions and Recovery	2-7
	Fault Display on HHT or DHT	2-7
	System Processor Faults (SP-XX)	2-7
	Velocity Processor (VP-XX)	2-12
	Current Processor Faults (CP-XX)	2-22
	Final Fault Recovery	2-32
 Chapter 3	 Malfunctions Not Indicated by a Fault	
	General	3-1
	Logic Control Malfunctions	3-1
	Link/Configuration Parameter Malfunctions	3-3
	Velocity Control Malfunctions	3-3
	Velocity Feedback Device Malfunction	3-9
	Encoder Device Malfunction	3-9
	Analog Tachometer Malfunction	3-13
	Armature Current Control	3-15
	Main Control Board Test Points	3-16
	Field Current Control	3-19
	Magnetics/Power Structure	3-22
	Series A	3-22
	Series B	3-29
	Auto Tuning Malfunctions (Series A & B)	3-34
 Chapter 4	 Using Trending to Aid Troubleshooting	
	General	4-1
	Trend Programming	4-1
	Examining Trend Data With a Program Terminal	4-3
	Examining Trend Data with the Node Adapter	4-4
	Examining Trend Data with the Discrete Adapter	4-4
	Examples of Trends	4-4
	System Considerations	4-7
	Ground Network Considerations	4-7
	Electrical Noise Control	4-8

Chapter 5	Manually Tuning the 1395 Drive	
	Introduction	5-1
	Tools & Test Equipment	5-1
	Current Loop Tuning	5-1
	Velocity Loop Tuning	5-3
	Field Flux Tuning	5-4
Chapter 6	Test Points	
	General.	6-1
	Main Control Board.	6-1
	Power Stage Interface/Switcher Board	6-3
	Power Stage Interface Board	6-4
	Power Supply Board	6-4
Appendix A	Parameter List/Record	
	General Checklist.	A-1
	Drive Nameplate Data	A-1
	Wiring and Control Board Checks.	A-1
	Measurement Record.	A-2
	Parameter Record.	A-3

Index

Understanding the Basic Principles

General

This guide is intended to help you define troubleshooting techniques and procedures and help simplify servicing of the Bulletin 1395 DC Drive by identifying likely causes for malfunction. The 1395 employs extensive diagnostics to aid in correcting many malfunctions that may occur in the system. This guide is designed to help interpret the diagnostic response of the Drive when a malfunction occurs. It will also aid in diagnosing malfunctions that do not solicit a fault response from the Drive. Possible corrective measures will be explained to help get the Drive repaired or functional as quickly as possible for all types of malfunctions.



ATTENTION: Only personnel familiar with the 1395 Drive System and the associated machinery should perform troubleshooting or maintenance functions on the Drive. Failure to comply may result in personal injury and/or equipment damage.

Required Equipment

In addition to a Bulletin 1300 Programming Terminal the following should be available before initiating any troubleshooting procedures:

- Digital Multimeter (DMM) capable of 1000VDC/750VAC, with a one megohm minimum input impedance.
- Assorted screwdrivers (Phillips and Straight).
- Clamp on Ammeter (AC/DC) with current ratings to 3X rated armature current output of 1395.
- Dual trace oscilloscope with differential capability, digital storage, with two X10 and one X100 calibrated probes. (Optional but recommended.)
- Hand Tachometer used to monitor motor velocities.
- Bulletin 1395 Installation Manuals for:
 - Programming Terminal (Bulletin 1300)
 - Adapter Boards

ESD Sensitivity Precaution



ATTENTION: This Drive may contain ESD (Electrostatic Discharge) sensitive parts and assemblies. Static control precautions are required when installing, testing, servicing or repairing this assembly. Component damage may result if ESD control procedures are not followed. If you are not familiar with static control procedures, reference U.S. Department of Defense, DOD-HDBK-263, Electrostatic Discharge Control Handbook for protection of Electronic Parts, Assemblies and Equipment or any other applicable ESD Protection Handbook.

During Start-up the following information should have been recorded for reference during troubleshooting. If it was not, record the following at this time:

- An accurate list of Drive Setup and Configuration parameters, in case the EEPROM is corrupted. Tables are supplied in Chapter 6 for this purpose.
- Software Version numbers should be recorded for each board. These are necessary to provide to on-site personnel or when calling for assistance.
- Drive and motor nameplate data should have been recorded at start-up and maintained for ready reference during troubleshooting. Many systems do not allow for easy access to the motor after startup. If the motor nameplate data was not recorded previously, attempt to do so at this time.



ATTENTION: When replacing boards containing firmware EPROM modules, Do Not transfer EPROMs from the damaged board to the replacement board. Electrostatic Discharge (ESD), Electromagnetic Interference (EMI), excessive heat, contamination of printed circuit boards (PCB), and connections that are damaged or improperly seated, etc., can cause serious malfunctions to occur in the 1395 drive. An attempt should be made to correct any of these environmental conditions prior to installing new components.

Safety Facts to Read Before Proceeding



ATTENTION: Severe injury or death can result from electrical shock, burn, or unintended actuation of controlled equipment. Hazardous voltages may exist in the cabinet even with the circuit breaker in the off position. Recommended practice is to disconnect and lock out control equipment from power sources, and discharge stored energy in capacitors, if present. If it is necessary to work in the vicinity of energized equipment, the safety related work practices of NFPA 70E, Electrical Safety Requirements for Employee Workplaces, must be followed. **DO NOT** work alone on energized equipment.



ATTENTION: Potentially fatal voltages may result from improper usage of oscilloscope and other test equipment. The oscilloscope chassis may be at a potentially fatal voltage if not properly grounded. If an oscilloscope is used to measure high voltage waveforms, use only a dual channel oscilloscope in the differential mode with X 100 probes. It is recommended that the oscilloscope be used in the A minus B Quasi-differential mode with the oscilloscope chassis correctly grounded to an earth ground. Refer to equipment safety instructions for all test equipment before using with the 1395.



ATTENTION: The CMOS devices used on the control circuit boards can be destroyed or damaged by static charges. If personnel will be working near static sensitive devices, they must be appropriately grounded. If you are not familiar with static control procedures, reference A-B publication 8000-4.5.2 Guarding Against Electrostatic Damage or any other applicable ESD Protection Handbook.

Notes:

Malfuncions with Indications

General

Most malfuncions that occur induce a fault response from the 1395 drive. This aids greatly in determining what malfunction has occurred. By recording all of the faults indicated by the 1395 and using the accompanying information, most problems can be corrected. The 1395 employs extensive diagnostics which monitor both internal and external operating conditions and responds to incorrect conditions as programmed by the user.

Hard Faults

A Hard Fault is the highest priority fault which indicates a condition in which the 1395 has detected an internal malfunction and has determined that operation can no longer continue. This type of fault indicates that a major internal component or system has malfunctioned and that control of the drive functions may be lost. The response of the drive to a Hard Fault is a coast stop or whenever possible, a controlled motor stop.

A rotating motor will stop according to the Torque Mode commanded. The following is an example of the action that will occur based on the value of Parameter 625 "Torque Mode"

1. If Parameter 625 = 0 (Zero Torque) the drive will immediately phase back the armature bridge and open the DC contactor.
2. If Parameter 625 = 1 (Velocity Regulate) the Drive will ramp the motor velocity to zero and then open the contactor.
3. If Parameter 625 = 2 (External Torque Regulate) the Drive will immediately phase back the armature bridge and open the DC contactor.
4. If Parameter 625 = 3 (Min Select) the Drive will immediately phase back the armature bridge and open the DC contactor.
5. If Parameter 625 = 4 (Max Select) the Drive will immediately phase back the armature bridge and open the DC contactor.
6. If Parameter 625 = 5 (Load Response) the Drive will immediately phase back the armature bridge and open the DC contactor.

When a Hard Fault has occurred, fault recovery can only be accomplished by initiating a system RESET or cycling AC line power. Examples of Hard Faults include:

Handshake Fault - A fault between processors that indicate communication or functionality was lost by one, or both processors.

Internal Memory Fault - A fault detected by a processor that indicates a component malfunction.

Soft Faults

A Soft Fault indicates a condition in which the 1395 has detected a malfunction that could cause damage to the drive control, power components, or the motor. It may also indicate that undesirable operating conditions exist external to the drive. This type of fault is used to protect the drive system components from damage due to both internal and external malfunctions. It differs from the Hard Fault in that the 1395 can, in most cases, maintain proper control during the fault.

A Soft Fault is a second priority fault. When it occurs the response of the drive is to initiate a coast stop or controlled motor stop. Fault recovery is accomplished by a Clear Fault command, a system RESET command, or by cycling AC line power.

Examples of Soft Faults are:

Velocity Feedback Loss - Fault detected when the selected feedback device malfunctions. The drive will respond with a coast stop.

SCR Overtemperature Trip - detected when the thermal switch opens on the power structure heat sink. The drive will respond by initiating a controlled motor stop.

Warning Faults

A Warning Fault is the lowest priority fault which indicates a condition that if left uncorrected, could result in a Soft Fault. This type of fault is designed to annunciate a condition present in the system. When a Warning Fault occurs, the appropriate Fault Code is entered into the Fault Queue and the Fault Status parameters reflect the condition present. The drive will not command a stop, and operation will continue unaffected. Fault Recovery is accomplished by initiating a Clear Fault command, but is not necessary for continued operation. Examples of Warning Faults are:

Motor Overload Pending - Detected when the armature current exceeds 115% (default value of parameter 720) of the motor armature current rating. The drive will respond by indicating a Warning Fault and entering a message into the Fault Queue, if parameter 632, bit 0 is set to zero.

Bridge Overload Pending - Detected when the armature current exceeds 105% of the bridge rating. The drive will respond by indicating a Warning Fault, and entering a message into the Fault Queue, if parameter 632, bit 2 is set to zero.

Fault Response Selection

A number of fault conditions in the 1395 may be configured to respond as either Soft or Warning type faults. This allows the user to control the response of the drive to some fault conditions based on his unique application requirements. Parameter 623 “Fault Select” is a bit coded word which controls whether eight predetermined faults will cause a Soft or Warning type response. Bit definitions for parameter 623, corresponding to the eight faults, are given in [Table 2.A](#). A fault condition will cause a Soft Fault at this time.

A Soft Fault response will occur if the corresponding bit is set to 1. A Warning response will occur if the corresponding bit is set to 0.

The default for all bits of parameter 623, when the parameter table is initialized, is 1. This causes all of the faults listed in [Table 2.A](#) to respond as a Soft Fault type. For a fault to respond as a Warning Fault, the corresponding bit must be set to 0 by the user. If the faults above are configured as Warning Faults, then a provision should be made to report these warnings through the PLC or other external device.

Configuring “Waiting Safe Arm Volts” (bit 5=0) and “Waiting Zero Arm Current” (bit 6=0) as Warning faults is recommended. This allows the current loop to attempt to correct the condition without causing nuisance trips. Drive operation is continued even when these faults are configured as Warning Faults. ALL other bits should be set to 1 in most applications.

Three warning faults can be disabled by bit manipulation of parameter 632:

Parameter 632	Associated Fault
Bit 0 = Motor Overload Pending	VP-16, (reference parameter 720)
Bit 1 = Excessive armature volts demand	VP-36
Bit 2 = Bridge Overload Pending	VP-39 (reference parameter 615)

If a bit is set to 1, that particular fault will not be reported in the fault word (parameter 100).

Table 2.A Fault Select Parameter 623

Bit	Fault Number	Fault Definition	Fault Description
0	VP-14	SCR Overtemp	Occurs when the SCR heat sink (HST) thermo switch reaches 85 degrees C (185 degrees F) for 1 second. If bit 0 = 1, then a fault occurrence will cause a controlled motor stop.
1	VP-15	Motor Overtemp	Occurs when the external overtemp discrete input is low for specified delay of Param 725. If bit 1 = 1, then a fault occurrence will cause a controlled motor stop.
2	VP-17	Overload Tripped	Occurs when the armature current output has exceeded the selected motor overload coefficients. These coefficients are selected in parameter 629 “Mtr Overload Sel”. If bit 2 = 1, then a fault occurrence will cause a controlled motor stop.
3	VP-18	Stall	Occurs when the armature current output is at current limit and velocity is within the zero speed tolerance (parameter 710) for the time specified in parameter 727 “Stall Delay”. If Bit 3 = 1, then a fault occurrence will cause a Coast Stop.
4	VP-20	AC Voltage	Occurs when the incoming AC line voltage exceeds +15% or -20% of voltage specified in parameter 617 “Rated AC Line” for 1 second. If Bit 4 = 1 then a fault occurrence will cause a controlled motor stop.
5	VP-34	Waiting Safe Arm Voltage	Occurs when armature CEMF is too high to allow successful commutation during a forward to reverse bridge change. If bit 5 = 1, then a fault occurrence will cause a Coast Stop. If bit 5 = 0, then an occurrence will cause the motoring bridge to be held off, allowing the motor to coast to a lower CEMF. When an acceptable level is reached the drive will allow a bridge change and operation will continue.
6	VP-35	Waiting Zero Arm Current	Occurs when the armature current does not go to zero when a bridge change is commanded. If bit 6 = 1, then a fault occurrence will cause a Coast Stop. If bit 6 = 0, then an occurrence will cause the drive to attempt to force the current to zero.
7	VP-31	Arm Bridge Overload Trip	Occurs when armature current output exceeds the predetermined armature bridge overload coefficients which are based on 150% for 60 seconds, 200% for 10 seconds, 260% for 5 seconds. If bit 7 = 1, then a fault occurrence will cause a Coast Stop.

Fault Setup Parameters

Certain Faults have setup parameters associated with them. They allow the user to set thresholds and time delays according to the particular application. A description of faults with setup parameters follows:

No.	Name	Description	Associated Parameter(s)
VP-10	Feedback Loss	This Soft fault occurs when the measured velocity feedback from the selected feedback device is less than parameter 732 "Tach Loss Vel" and the CEMF of the motor is greater than parameter 731 "Tach Loss CEMF". Velocity Fdbk (106) < Tach Loss Vel (732), AND calculated CEMF from Arm Voltage Fdbk (105) > Tach Loss CEMF (731), THEN Fault on Feedback Loss.	Parameter 731 "Tach Loss CEMF". This parameter indicates the lower limit of CEMF of the motor voltage allowed for determination of feedback loss. Programmable range is 0-33%. Parameter 732 "Tach Loss VEL" This parameter indicates the upper limit of velocity feedback measured by the selected feedback device allowed for determination of feedback loss. Programmable range is 0.244, ±10%. Parameter 731 "Tach Loss CEMF" must always be programmed to a value greater than parameter 732 "Tach Loss VEL" or nuisance trips will occur.
VP-12	Absolute Overspeed	This Soft fault occurs when motor velocity exceeds the maximum forward/reverse speed limits by the absolute overspeed level.	Parameter 724 "ABS Overspeed" This parameter indicates the incremental motor velocity (RPM) above parameter 607 "Rev Speed Limit" or parameter 608 "Fwd Speed Limit" that must be detected in parameter 106 "Velocity Fdbk" to cause the above fault. Programmable range is zero to Base Speed. See also parameters 607 "Rev Speed Limit" and 608 "Fwd Speed Limit".
VP-13	MotorField Loss	This Soft fault occurs when the field current feedback is less than 50% of field current reference for the time delay specified.	Parameter 730 "Fld Failure Dly" This parameter indicates the time the field current feedback must remain less than 50% of the field current reference before the above fault is indicated. Programmable range is 0-5 seconds. Parameter 627 "Flux Mode Select". Bit 6 can be used to disable field loss detection. For normal operation, set it to 0 to detect field loss conditions.



ATTENTION: Uncontrolled motor rotation can cause injury or equipment damage if field loss detection is disabled. Field loss protection can only be disabled if using an external field supply. Set bit 6 to disable field loss detection.

VP-14	SCR Overtemp	This fault occurs when the SCR heat sink (HST) thermoswitch and/or vane switch (MKVA) opens after the specified time delay.	Parameter 726 "SCR Overtemp Dly". This parameter indicates the time the thermoswitch must remain open before the above fault is indicated. Programmable range: 0-3276.7 secs.
VP-15	External Overtemp	This selectable fault occurs when the external overtemp discrete input (TB3-1& 2) is low for the time delay specified.	Parameter 725 "Motor Ovtemp Dly". This parameter indicates the time the discrete input must remain low before the above fault is indicated. Programmable range: 0-3276.7 secs. Verify that the motor thermostat is properly wired. If the motor is not equipped with a thermostat, 115 VAC or 24V DC must still be applied to TB3 terminal 2. See 1395 Installation Manual (publication 1395-5.40).

No.	Name	Description	Associated Parameter(s)
VP-16	Thermal Overload Pending	This Warning fault occurs when the armature current exceeds the Motor Overload Pending Level.	Parameter 720 "Ovrlid Pend Level". It is used to indicate that the present armature current output exceeds a predetermined level and continued operation at this level may cause damage to the motor and/or process. This warning fault can be disabled. Refer to Parameter 632.
VP-17	Thermal Overload Tripped	This selectable fault occurs when armature current output over time has exceeded the selected motor overload coefficients.	Parameter 629 "Mtr Overload Sel". This parameter is used to select the coefficients for the motor thermal overload function. 0. Overload function disabled 1. 60 seconds to trip at 150% armature current for externally cooled motors. 2. 60 seconds to trip at 200% armature current for externally cooled motors. 3. 60 seconds to trip at 150% armature current for self cooled motors. 4. 60 seconds to trip at 200% armature current for self cooled motors.
VP-18	Motor Stalled	This selectable fault occurs when the armature output is at current limit and velocity is within the zero speed tolerance for the time delay specified.	Parameter 727 "Stall Delay". This parameter indicates the time that the armature current must remain at current limit with the motor velocity within the zero speed tolerance before the above fault is indicated. Programmable range: 0-100 seconds. See also parameters 663 "Fwd Brdg Cur Lim", 664 "Rev Brdg Cur Lim", and 710 "Zero Speed Tol".
VP-20	AC Voltage	This selectable fault occurs when the incoming AC line voltage exceeds +15% or -20% of rated AC line voltage for the time delay specified.	Parameter 617 "Rated AC Line". This parameter indicates the incoming AC line voltage and is used as a basis for the above comparison and resulting fault. Programmable range: 150-460V. Parameter 728 "AC Line Tol Dly". This parameter indicates the time the AC Line must remain out of tolerance before the above fault is indicated. Programmable range: 0-1.0 secs.

Fault Status Indicators

The Bulletin 1395 contains various Fault Status Indicators which can be used to monitor the faults that occur in the drive. These are available for use with the Bulletin 1300 Programming Terminal (DHT/DMT), the PLC/Node adapter, the PLC/Data Highway +, the Multi Communication Adapter and through the use of discrete I/O devices.

Fault Status Indicators																																																					
Parameter	Name	Description																																																			
100	Logic Status	Parameter 100 uses bits 0 and 1 to indicate the highest priority fault level present in the drive. The two bits are binary coded to allow for four different indications. This source configuration parameter can be linked to various adapters depending on the application. It can also be monitored by the Programming Terminal.																																																			
			<table border="1"> <thead> <tr> <th>Bit 1</th> <th>Bit 0</th> <th>Definition</th> </tr> </thead> <tbody> <tr> <td>0</td> <td>0</td> <td>No Fault</td> </tr> <tr> <td>0</td> <td>1</td> <td>Warning Fault</td> </tr> <tr> <td>1</td> <td>0</td> <td>Soft Fault</td> </tr> <tr> <td>1</td> <td>1</td> <td>Hard Fault</td> </tr> </tbody> </table>	Bit 1	Bit 0	Definition	0	0	No Fault	0	1	Warning Fault	1	0	Soft Fault	1	1	Hard Fault																																			
			Bit 1	Bit 0	Definition																																																
			0	0	No Fault																																																
			0	1	Warning Fault																																																
1	0	Soft Fault																																																			
1	1	Hard Fault																																																			
101	Drive Fault	Parameter 101 is a bit coded source configuration parameter that can report the status of Soft and Warning Faults that exist in either the Current Processor or Velocity Processor. The selection between Current Processor or Velocity Processor faults is made in the setup parameter 630 "Fault Report".																																																			
630	Fault Report	Parameter 630 is a setup parameter which determines whether the Current or Velocity Processor faults will be reported. If parameter 630 = 0, then Current Processor faults will be reported in parameter 101. If parameter 630 = 1, then Velocity Processor faults will be reported in parameter 101. The corresponding bit definitions can be found below.																																																			
		<table border="1"> <thead> <tr> <th>Bit</th> <th>Fault Definition(630=0)</th> <th>Fault Definition(630=1)</th> </tr> </thead> <tbody> <tr> <td>0</td> <td>CP-06 Phase Loss</td> <td>VP-10 Feedback Loss</td> </tr> <tr> <td>1</td> <td>CP-05 Logic Power Supply</td> <td>ECOAST Status (0=Closed, 1=Open)⁽¹⁾</td> </tr> <tr> <td>2</td> <td>CP-08 AC Overcurrent Trip</td> <td>VP-12 Absolute Overspeed</td> </tr> <tr> <td>3</td> <td>CP-09 DC Fault (Overcurrent)</td> <td>VP-13 Motor Field Tolerance</td> </tr> <tr> <td>4</td> <td>CP-07 Overcurrent Trip (AC/DC)</td> <td>VP-14 SCR Overtemp</td> </tr> <tr> <td>5</td> <td>VP-31 Arm Bridge Overload Trip</td> <td>VP-15 External Overtemp</td> </tr> <tr> <td>6</td> <td>VP-32 Motor Field Loss</td> <td>VP-16 Thermal Overload Pending</td> </tr> <tr> <td>7</td> <td>Defined for internal use only</td> <td>VP-17 Thermal Overload Tripped</td> </tr> <tr> <td>8</td> <td>VP-34 Waiting Safe Arm Voltage</td> <td>VP-18 Motor Stalled</td> </tr> <tr> <td>9</td> <td>VP-35 Waiting Zero Arm Current</td> <td>VP-19 Contactor Failure</td> </tr> <tr> <td>10</td> <td>Excessive Arm Voltage Demand</td> <td>VP-20 AC Voltage</td> </tr> <tr> <td>11</td> <td>Defined for internal use only</td> <td>VP-21 VP Handshake with SP</td> </tr> <tr> <td>12</td> <td>Defined for internal use only</td> <td>VP-22 VP Handshake with CP</td> </tr> <tr> <td>13</td> <td>VP-39 Arm Bridge Overload Pend</td> <td>VP-23 SP Mode Request Not Honored</td> </tr> <tr> <td>14</td> <td>Not Used</td> <td>VP-24 CP Not in VP Requested Mode</td> </tr> <tr> <td>15⁽²⁾</td> <td>Status of Param 630 "Fault Report"</td> <td>Status of Parameter 630 "Fault Report"</td> </tr> </tbody> </table>	Bit	Fault Definition(630=0)	Fault Definition(630=1)	0	CP-06 Phase Loss	VP-10 Feedback Loss	1	CP-05 Logic Power Supply	ECOAST Status (0=Closed, 1=Open) ⁽¹⁾	2	CP-08 AC Overcurrent Trip	VP-12 Absolute Overspeed	3	CP-09 DC Fault (Overcurrent)	VP-13 Motor Field Tolerance	4	CP-07 Overcurrent Trip (AC/DC)	VP-14 SCR Overtemp	5	VP-31 Arm Bridge Overload Trip	VP-15 External Overtemp	6	VP-32 Motor Field Loss	VP-16 Thermal Overload Pending	7	Defined for internal use only	VP-17 Thermal Overload Tripped	8	VP-34 Waiting Safe Arm Voltage	VP-18 Motor Stalled	9	VP-35 Waiting Zero Arm Current	VP-19 Contactor Failure	10	Excessive Arm Voltage Demand	VP-20 AC Voltage	11	Defined for internal use only	VP-21 VP Handshake with SP	12	Defined for internal use only	VP-22 VP Handshake with CP	13	VP-39 Arm Bridge Overload Pend	VP-23 SP Mode Request Not Honored	14	Not Used	VP-24 CP Not in VP Requested Mode	15 ⁽²⁾	Status of Param 630 "Fault Report"	Status of Parameter 630 "Fault Report"
Bit	Fault Definition(630=0)	Fault Definition(630=1)																																																			
0	CP-06 Phase Loss	VP-10 Feedback Loss																																																			
1	CP-05 Logic Power Supply	ECOAST Status (0=Closed, 1=Open) ⁽¹⁾																																																			
2	CP-08 AC Overcurrent Trip	VP-12 Absolute Overspeed																																																			
3	CP-09 DC Fault (Overcurrent)	VP-13 Motor Field Tolerance																																																			
4	CP-07 Overcurrent Trip (AC/DC)	VP-14 SCR Overtemp																																																			
5	VP-31 Arm Bridge Overload Trip	VP-15 External Overtemp																																																			
6	VP-32 Motor Field Loss	VP-16 Thermal Overload Pending																																																			
7	Defined for internal use only	VP-17 Thermal Overload Tripped																																																			
8	VP-34 Waiting Safe Arm Voltage	VP-18 Motor Stalled																																																			
9	VP-35 Waiting Zero Arm Current	VP-19 Contactor Failure																																																			
10	Excessive Arm Voltage Demand	VP-20 AC Voltage																																																			
11	Defined for internal use only	VP-21 VP Handshake with SP																																																			
12	Defined for internal use only	VP-22 VP Handshake with CP																																																			
13	VP-39 Arm Bridge Overload Pend	VP-23 SP Mode Request Not Honored																																																			
14	Not Used	VP-24 CP Not in VP Requested Mode																																																			
15 ⁽²⁾	Status of Param 630 "Fault Report"	Status of Parameter 630 "Fault Report"																																																			

(1) Bit 1 ECOAST Status is not a fault indicator but does allow the operator to monitor, through a source configuration parameter, whether the ECOAST circuit is closed. The ECOAST string allows the drive to close the DC contactor. If the string is closed bit 1 will be set to 0 and the DC contactor will be allowed to close if commanded. If the circuit is open then bit 1 will be set to 1 and the DC contactor will be held open.

(2) Bit 15 in either selection reflects the present status of parameter 630 "FaultReport". If bit 15 is 0 then the Current Processor Fault status is being reflected in parameter 101. If bit 15 is 1 then the Velocity Processor Fault Status is being reflected.

Bulletin 1300 Programming Terminal

You can also use the Bulletin 1300 Programming Terminals to monitor the terminal fault status of the 1395 drive. Any of the fault status parameters (100, 101, 630) can be monitored through the Programming Terminal. Use Main Menu item 3 “*Parameter*”.

In addition, when a Hard or Soft Fault occurs, the fault message will appear immediately on the screen of the programming terminal. To view all of the faults in the Fault Queue, select Main Menu item 7 “*Faults*”. Then select Fault Menu Item 1 “*View Faults*” to view the last 16 faults that occurred. Use the INC/DEC keys to move through the Fault Queue for that processor. Use the ENTER key to view other processor’s fault queues if they exist. All types of detectable faults that have occurred will be present in the Fault Queue.

Any problems with the Programming Terminal itself will be evidenced by a missing or non-active Pendulum on the initial display. If programming terminal problems are suspected, refer to the terminal instruction manual.

Fault Descriptions and Recovery

Each processor in the 1395 drive has unique fault detection and message capabilities which it can generate. These fault diagnostics can consist of Hard, Soft, or Warning type faults and can cause the drive to respond in various ways. The faults detected by each processor are listed, along with a complete description, possible causes and possible fault recovery procedures that will allow the malfunction to be corrected.

A recurring fault, as referenced below in the *Recovery* procedure, refers to a fault that repeats as soon as normal operation is attempted. Faults that reoccur at random intervals may be due to a transient condition and not necessarily a board or component malfunction.

Fault Display on HHT or DHT

No.	Name	Description	Recovery
10	Comm Fault	Attempting to re-establish communication.	<ol style="list-style-type: none"> 1. Drive may be held in a continual reset. If Reset/Stop input TB3-3, is held high (24 or 115 volts applied), and parameter 620 = 0 (Default setting), Drive will be in a continual reset. Set parameter 620 to a non zero value. 2. Check integrity of PE and TE ground. Check for “Floating” TE, or ground loops

System Processor Faults (SP-XX)

In general most System Processor faults indicate that an internal processor error somewhere in the 1395 system has occurred. These faults can be induced by Electrostatic Discharge (ESD), Electro Magnetic Interference (EMI), excessive heat, contamination of printed circuit boards (PCB), connections that are damaged or do not seat properly, etc. An attempt should be made to correct any of these environmental conditions prior to replacing components in the drive. This should reduce the possibility of reoccurrence. If board replacement is necessary, replace the complete board, DO NOT reuse EPROM chips.

System Processor Faults			
No.	Name	Description	Recovery
SP-00	Ill Fault (Warning)	Internal processor error was detected and corrected. Operation is unaffected.	No action is required.
SP-01	Proc OK		
SP-10	Queue Bad Dest (Warning)	Internal processor error was detected and corrected. An unsolicited reply (possibly due to noise) from a non-existing device could cause this warning fault. Operation is unaffected. Could also be caused by incorrect block transfer data or byte length.	No action is required or correct block transfer data.
SP-11	Queue Bad Tag (Warning)	Internal processor error was detected and corrected. Operation is unaffected.	No action is required.
SP-14	Queue RX Msg Index (Warning)	Internal processor error was detected and corrected. Operation is unaffected.	No action is required.
SP-15	Queue TX Msg Index (Warning)	Internal processor error was detected and corrected. Operation is unaffected.	No action is required.
SP-16	VP Write Fault (Warning)	Internal processor error was detected and corrected. Operation is unaffected.	No action is required.
SP-17	CP Write Fault (Warning)	Internal processor error was detected and corrected. Operation is unaffected.	No action is required.
SP-18	PB Write Fault (Warning)	Internal processor error was detected and corrected. Operation is unaffected.	No action is required.
SP-19	PA Write Fault (Warning)	Internal processor error was detected and corrected. Operation is unaffected.	No action is required.
SP-20	VP Read Fault (Warning)	Internal processor error was detected and corrected. Operation is unaffected.	No action is required.
SP-21	CP Read Fault (Warning)	Internal processor error was detected and corrected. Operation is unaffected.	No action is required.
SP-22	PB Read Fault (Warning)	Internal processor error was detected and corrected. Operation is unaffected.	No action is required.
SP-23	PA Read Fault (Warning)	Internal processor error was detected and corrected. Operation is unaffected.	No action is required.
SP-24	Recv Timeout (Warning)	Internal processor error was detected and corrected. Operation is unaffected.	No action is required.
SP-25	Bad Channel Value (Soft)	Internal processor error detected. A controlled motor stop will be initiated.	Execute a Clear Fault and continue operation. If the fault reoccurs, replace Main Control Board.
SP-30	EEPROM None or Empty (Soft)	Either the EEPROM is not installed or it has not been initialized. This fault may also occur if the data in the EEPROM has been corrupted. All Setup and Configuration data does not exist and the Drive Start-up Procedure must be repeated.	Check that the EEPROM is installed in UMC8 on the Main Control Board. Execute an "initialize" and repeat the Drive Start-up Procedure. Clear faults before attempting to operate the drive.
SP-32	EEPROM Verify (Soft)	A data write to the EEPROM cannot be accomplished. This indicates that the EEPROM component has malfunctioned.	Check J14 Jumper on Main Control Board for Write Protect Position. If the fault reoccurs Replace the Main Control Board and repeat the Drive Start-up Procedure before attempting to operate the drive.
SP-35	Handshake VP (Hard)	Internal communication between processors has malfunctioned. A controlled motor stop will be initiated.	Verify DMT has filter installed. Execute System RESET or cycle power and attempt normal operation. If the fault reoccurs, check integrity of TE and PE grounding before replacing Main Control Board.

System Processor Faults			
No.	Name	Description	Recovery
SP-38	Handshake PB (Hard)	Internal communication between the System Processor and the Port B Adapter Board has Malfunctioned. A controlled motor stop will be initiated.	Execute System RESET or cycle power and attempt normal operation. Check the ribbon connector that plugs into J6 on the Main Control Board and the Adapter Board, replace if damage is suspected. If the malfunction reoccurs, replace the Adapter Board. If the malfunction still reoccurs check integrity of TE and PE grounding before replacing the Main Control Board.
SP-39	Handshake PA (Hard)	Internal communication between the System Processor and the Port A Adapter Board has malfunctioned. A controlled motor stop will be initiated.	Execute System RESET or cycle power and attempt normal operation. Check the ribbon connector that plugs into J7 on the Main Control Board and the Adapter Board, replace if suspect. If the fault reoccurs, replace the Adapter Board. If the fault still reoccurs, check integrity of TE and PE grounding before replacing the Main Control Board.
SP-43	Port Configd-No Adapter (Soft)	The System Processor has detected that an Adapter Board, which has configuration parameters linked to it, is not installed. This could result in undesirable operation. This fault may also occur when trying to link configuration parameters to non-existing adapters.	The missing Adapter Board should be replaced or the configuration parameters linked to the missing adapter should be removed. A System RESET can then be executed and operation continued.



ATTENTION: Do Not execute a Clear Fault without correcting the cause of the fault. This will allow the drive to operate and may cause undesirable operation. The hazard of personal injury or equipment damage exists if faults are not corrected.

SP-50	Mode VP/CP Timeout (Hard)	Internal communication between processors has malfunctioned. A controlled motor stop will be initiated.	Execute System RESET or cycle power and attempt normal operation. If the fault reoccurs, replace Main Control Board.
SP-51	Mode PB Timeout (Hard)	Internal communication between the System Processor and the Port B Adapter has malfunctioned. A controlled motor stop will be initiated.	Execute System RESET or cycle power and attempt normal operation. If the fault reoccurs, replace the Port B Adapter. If the fault reoccurs, replace the Main Control Board.
SP-52	Mode PA Timeout (Hard)	Internal communication between the System Processor and the Port A Adapter has malfunctioned. A controlled motor stop will be initiated.	Execute System RESET or cycle power and attempt normal operation. If the fault reoccurs, replace the Port A Adapter. If the fault persists, replace the Main Control Board.
SP-53	Processor VP Faulted (Hard)	The Velocity Processor has been detected as being in a faulted state. A controlled motor stop will be initiated.	Check the Fault Queue to see if the Velocity Processor fault may have been recorded. These faults must be corrected before further operation. Execute System RESET or cycle power and attempt normal operation. If the fault reoccurs, replace the Main Control Board.

System Processor Faults			
No.	Name	Description	Recovery
SP-54	Processor PB Faulted (Soft)	The Port B Adapter has been detected as being in a faulted state. A controlled motor stop will be initiated.	Check the Fault Queue to see if the Adapter fault may have been recorded. These faults must be corrected before further operation. Execute a Clear Fault and attempt normal operation. If the fault reoccurs, replace the Port B Adapter. If the fault reoccurs, replace the Main Control Board.
SP-55	Processor PA Faulted (Soft)	The Port A Adapter has been detected as being in a faulted state. A controlled motor stop will be initiated.	Check the Fault Queue to see if the Adapter fault may have been recorded. These faults should be corrected before further operation. Execute System RESET or cycle power and attempt normal operation. If the fault reoccurs, replace the Port A Adapter. If the fault occurs again, replace the Main Control Board.
SP-56	Illegal Mode Request (Soft)	Internal processor communication error detected. A controlled motor stop will be initiated.	Execute a Clear Fault and continue operation. If the fault reoccurs, replace Main Control Board.
SP-57	Loc Mode Serial Timeout (Soft)	This occurs when the Bulletin 1300 Programming Terminal is in LOCAL CONTROL and serial communication is interrupted. A controlled motor stop will be initiated. This fault most often occurs when the programming terminal has LOCAL CONTROL and the serial cable to the drive is unplugged or damaged.	Check the programming terminal connection to the drive. The connector is located next to the TB3 terminal strip on the 1396. Also check the connection on the programming terminal back if it is a Door Mounted Terminal (DMT). Execute a Clear Fault and continue operation. If the fault reoccurs, replace the Programming Terminal and/or cable. If the fault reoccurs again, replace the cable assembly from the Main Control Board's J4 to the D-Shell connector next to TB3. If the fault is still persistent, replace the Main Control Board.
SP-58	Task Timeout (Hard)	Internal processor error detected. A controlled motor stop will be initiated.	Execute System RESET or cycle power and attempt normal operation. If the fault reoccurs, replace Main Control Board.
SP-60	Processor VP Hard (Hard)	The Velocity Processor has been detected as being in a Hard Fault state and is non-operational. A coast stop will be initiated. This fault usually occurs when the Velocity Processor has malfunctioned during power-on diagnostics or has experienced a major interruption of operation.	Check the Fault Queue to see if the Velocity Processor fault may have been recorded. These faults must be corrected before further operation. Execute System RESET or cycle power and attempt normal operation. Check TE & PE grounding, if the fault continues to reoccur, replace the Main Control Board.
SP-61	Processor CP Hard (Hard)	The Current Processor has been detected as being in a Hard Fault state and is non-operational. A coast stop will be initiated. This fault usually occurs when the Current Processor has malfunctioned during power-on diagnostics or has experienced a major interruption of operation.	Check the Fault Queue to see if the Current Processor fault may have been recorded. These faults must be corrected before further operation. Execute System RESET or cycle power and attempt normal operation. Check TE & PE grounding, if the fault continues to reoccur, replace the Main Control Board.

System Processor Faults			
No.	Name	Description	Recovery
SP-62	Processor PB Hard (Hard)	The Port B Adapter Processor has been detected as being in a Hard Fault state and is non-operational. A controlled motor stop will be initiated. This fault usually occurs when the Adapter's processor has failed power-on diagnostics or has experienced a major interruption of operation.	Check the Fault Queue to see if the Adapter's processor fault may have been recorded. These faults should be corrected before further operation. Execute System RESET or cycle power and attempt normal operation. If the fault reoccurs, replace the Port B Adapter. Check TE & PE grounding, if the fault continues to reoccur, replace the Main Control Board.
SP-63	Processor PA Hard (Hard)	The Port A Adapter Processor has been detected as being in a Hard Fault state and is non-operational. A controlled motor stop will be initiated. This fault usually occurs when the Adapter's processor has malfunctioned during power-on diagnostics or has experienced a major interruption of operation.	Check the Fault Queue to see if the Adapter's processor fault may have been recorded. These faults must be corrected before further operation. Execute System RESET or cycle power and attempt normal operation. If the fault reoccurs, replace the Port A Adapter. Check grounding, if the fault occurs again, replace the Main Control Board.
SP-64	VP/CP Flt Mode, No Status (Soft)	Internal processor communication error detected. A controlled motor stop will be initiated.	Execute a Clear Fault and continue operation. If the fault reoccurs, replace Main Control Board.
SP-65	PB Flt Mode, No Status (Soft)	Internal communication between the System Processor and the Port B Adapter has malfunctioned. A controlled motor stop will be initiated.	Execute a Clear Fault and attempt normal operation. If the fault reoccurs, replace the Port B Adapter. If the fault occurs again, replace the Main Control Board.
SP-66	PA Flt Mode, No Status (Soft)	Internal communication between the System Processor and the Port A Adapter has malfunctioned. A controlled motor stop will be initiated.	Execute a Clear Fault and attempt normal operation. If the fault reoccurs, replace the Port A Adapter. If the fault occurs again, replace the Main Control Board.
SP-83	Diag EEPROM (Soft)	The EEPROM checksum calculated during power-on diagnostics is incorrect. This usually indicates that data contained in the EEPROM has been corrupted.	Execute a Clear Fault. Re-initialize EEPROM again, re-load program and clear fault. If the fault reoccurs often, then replace the Main Control Board.
SP-85	Diag VP Mbus (Hard)	Internal processor error occurred during power-up diagnostics.	Execute System RESET or cycle power and attempt normal operation. Check grounding, if the fault reoccurs, replace Main Control Board.
SP-86	Diag Adapter B Mbus (Hard)	An internal communication error between the System Processor and the Port B Adapter board has occurred during power-on.	Execute System RESET or cycle power and attempt normal operation. Check the ribbon connector that plugs into J6 on the Main Control Board and the Adapter Board, replace if damage is suspected. If the fault reoccurs check grounding first, then replace the Adapter Board. If the fault persists, replace the Main Control Board.

System Processor Faults			
No.	Name	Description	Recovery
SP-87	Diag Adapter A Mbus (Hard)	An internal communication error between the System Processor and the Port A Adapter board has occurred during power-on.	Execute System RESET or cycle power and attempt normal operation. Check the ribbon connector that plugs into J7 on the Main Control Board and the Adapter Board, replace if damage is suspected. If the fault reoccurs check grounding first, then replace the Adapter Board. If the fault still occurs, replace the Main Control Board.
SP-90	Serial WDG Warning (Warning)	Internal processor error was detected and corrected. Operation is unaffected.	No action is required.
SP-91	Serial WDG Soft (Soft)	Internal processor error detected. A controlled motor stop will be initiated.	Execute a Clear Fault and attempt normal operation. If the fault reoccurs, replace Main Control Board.

Velocity Processor (VP-XX)

The Velocity Processor is responsible for fault monitoring of control variables throughout the drive. This includes monitoring velocity control, armature and field outputs to the motor, incoming line conditions, and communications to the System Processor and Current Processor. These faults can be induced by problems external to the immediate drive such as a malfunction of a feedback device, excessive load on the motor, incoming line variations, etc. An attempt to identify and correct these conditions, if applicable, must be done prior to replacing components in the drive.

Internal processor faults that occur can be induced by Electrostatic Discharge (ESD), Electro Magnetic Interference (EMI), excessive heat, contamination of printed circuit boards (PCB), improper or damaged connections, etc. An attempt must be made to correct any of these environmental conditions prior to replacing components in the drive. This can help reduce the possibility of reoccurrence.

Faults VP-10 through VP-24 are reported in parameter 101 “Drive Fault” when parameter 630 “Fault Report” is set to a value of 1. The bit assignments for parameter 101 are given in () where applicable. See Fault Type Selection.

Velocity Processor Faults			
No.	Name	Description	Recovery
VP-10	Feedback Loss (Selectable Soft or Warning) (Parameter 101 bit 0 when Parameter 630=1)	<ul style="list-style-type: none"> The following applies when VP-10 is configured as a soft fault: <p>The velocity measured from the feedback device is less than the level programmed in parameter 732 "Tach Loss Vel" and the velocity calculated from the CEMF of the motor is greater than the level programmed in parameter 731 "Tach Loss CEMF". A coast stop will be initiated.</p> <p>If parameter 106 "Velocity Fdbk" < parameter 732 "Tach Loss Vel" AND calculated CEMF from param 105 "Arm Voltage Fdbk" > param 731 "Tach Loss CEMF" THEN fault on VP-10 Feedback Loss.</p> <p>In general terms when the velocity measured from the feedback device, either an Encoder or a DC Tach, is less than the value programmed in parameter 732 "Tach Loss Vel" then the first condition of this test is met. Parameter 732 is usually programmed to a value which represents a velocity very close to zero speed, typically 0-5% of base speed. The CEMF of the motor is directly proportional to velocity below base speed, but is not dependent on the feedback device. When the calculated CEMF is greater than the value programmed in parameter 731 "Tach Loss CEMF" then the second condition of the test is met.</p> <p>Parameter 731 is usually programmed to a value of CEMF which represents a velocity significantly above zero speed, typically 5-30% of Motor rated CEMF. The measured value of CEMF is represented in parameter 105 "Arm Voltage Fdbk". Both conditions listed above must be met before the fault is generated.</p> <p>To set up the associated parameters for safe operation use these general guidelines. The higher the value of parameter 731 "Tach Loss CEMF", the greater the velocity of the motor before a Feedback Loss is detected. If parameter 731 is too high, excessive velocity can be reached before the drive faults. This can be especially true in applications requiring very fast acceleration and deceleration rates, high current limits, and low inertias. If the value is too low, nuisance faults may occur. Likewise, the higher the value of parameter 732 "Tach Loss Vel" the more likely nuisance faults may occur. If the value is too low then noise in the velocity feedback signal could keep the fault from occurring when indeed a feedback loss has occurred, especially with an analog DC Tach feedback device.</p>	<p>The method of recovery varies greatly depending on the cause of the fault.</p> <ol style="list-style-type: none"> 1. The feedback device (encoder or DC Tach), may have failed and correct operation should be verified. See page 3-9 for details. If the feedback device has malfunctioned, then replace it and execute a Clear Fault to continue operation. 2. Check jumpers J8, J9, J10 on Main Control Board for 5V or 12V encoder output selection. DO NOT use channel Z, Only A, A NOT, B, B NOT are to be used. 3. Verify that the encoder power supply has not folded back due to a short circuit or excessive current draw. +12V (+/-5%) must be present between TB3-14 & 13. If the measured voltage is less than 1 volt, the supply has folded back. Remove the power supply connections to the encoder at those terminals and cycle power to the drive. This will reset the encoder power supply foldback circuit. If Voltage is now present a short circuit or malfunction of the feedback device has occurred and must be corrected. If the +12V is not present after cycling power, replace the Main Control Board. 4. Verify that 621 "Fdbk Device Type" has the proper device selected. If incorrect, select the entry that matches the device being used and execute a Clear Fault to continue. 5. If an encoder is being used, verify that 609 "Encoder PPR" matches the PPR (Pulses per Revolution) of the encoder being used. Correct the entry and execute a Clear Fault. 6. If a DC Tach is being used, verify that the Analog Input Channel is properly configured to parameter 156 "Tach Velocity". Also verify the scaling and offset parameters associated with the analog channel are correctly set-up. Pay close attention to the polarity of the tach signal in respect to direction of rotation. Properly scale and offset the analog channel and execute a Clear Fault to continue operation. 7. Verify that parameter 610 "Rated Motor Volt" matches the nameplate rating of the motor. Also verify that parameter 739 "K Arm Volts" is properly scaled to assure that the armature voltage being monitored is accurate. To verify the scaling of parameter 739, rotate the motor under armature voltage feedback and compare the measured armature voltage, A1 to A2 with a DVM, to the reported armature voltage as reflected in parameter 105 "Arm Voltage Fdbk". <p>Note: If using armature voltage feedback to troubleshoot the feedback loss, the set-up procedure for armature voltage feedback must be performed first for proper operation.</p>

Velocity Processor Faults			
No.	Name	Description	Recovery
VP-10 (cont.)	Feedback Loss (Selectable Soft or Warning) (Parameter 101 bit 0 when Parameter 630=1)	<p>This fault is disabled if under param 621 "Feedback Device Type", No Feedback Device is selected.</p> <ul style="list-style-type: none"> The following applies when VP-10 is configured as a warning fault: <p>Tach loss can be configured as a warning fault if parameter 691 "Tach Switch Sel" has been set to 1.</p> <p>When this feature is enabled, a loss of feedback is detected and the drive goes into Tach Loss Recovery mode. Refer to 1395 Installation Manual.</p> <p>The drive runs in Armature Voltage Feedback as soon as a Warning is given; the process accuracy may change.</p>	<p>8. Verify the armature resistance compensation. This value effects the calculated CEMF of the motor. Parameter 614 should be programmed between 3-15% for typical motors.</p> <p>9. Verify that the Field parameters are correctly setup because this can also effect the accuracy of the armature voltage generated. Reference the Start-up Procedure in the Installation Manual for field parameter calibration.</p> <p>10. Nuisance trips occur at random but no actual loss of velocity feedback can be detected, re-evaluate the values entered for parameters 731 "Tach Loss CEMF" and 732 "Tach Loss Vel". Increase parameter 731 and decrease 732 by approximately 20% to decrease the overall sensitivity of the feedback loss test. Execute a Clear Fault and continue operation.</p> <p>11. Verify encoder wiring (i.e. loose encoder case ground or terminal strip ground).</p> <p>12. An error in feedback can occur without a VP-10 fault. Example: 106 indicates 75 RPM, but actual speed is 300 RPM. Verify correct value in 609, check encoder & wiring.</p>
VP-12	Absolute Overspeed (Soft) (Parameter 101 bit 2 when Parameter 630=1)	<p>An Absolute Overspeed fault will occur when the measured motor velocity, displayed in parameter 106 "Velocity Fdbk", exceeds either parameter 607 "Rev Speed Limit" or parameter 608 "Fwd Speed Limit" by the value specified in parameter 724 "ABS Overspeed". A coast stop will be initiated.</p> <p>If Velocity Fdbk < Rev Speed Limit-ABS Overspeed THEN Fault on VP-12 Absolute Overspeed OR IF Velocity Fdbk > Fwd Speed Limit + ABS Overspeed THEN Fault on VP-12 Absolute Overspeed.</p> <p>The Fwd and Rev Speed Limit parameters specify the level at which all velocity commands will be clamped. Parameter 608 "Fwd Speed Limit" sets the forward direction speed clamp while parameter 607 "Rev Speed Limit" sets the reverse direction clamp. Parameter 724 "ABS Overspeed" specifies the incremental speed above the limits that is allowable before an absolute overspeed fault occurs. This value is the same for either forward or reverse operation even though the speed limits may be at different values. This fault is disabled if the drive has armature voltage feedback or No Feedback Device selected in parameter 621.</p>	<p>The method of recovery varies greatly depending on the cause of the fault. The following may have contributed.</p> <ol style="list-style-type: none"> 1. An overhauling load on the motor may have overcome the torque output of the drive or motor and thus velocity control was lost. Correct the situation and execute a Clear Fault. 2. Check the absolute overspeed threshold level programmed in 724 "ABS Overspeed". Typical value is 10% of programmed speed limits to allow normal amounts of velocity overshoot. 3. If parameter 625 "Torque Mode" is inadvertently commanded to (2) External Torque Regulate, (3) Min Select, or (4) Max Select mode while operating as a stand alone or master drive of a system, velocity regulation would be lost and the motor velocity may become excessive causing this fault. Correct the mode command and execute a Clear Fault to continue. 4. If the velocity loop is improperly tuned the velocity of the motor may overshoot excessively during a step type velocity reference change, causing this fault. Check the gains of the velocity loop and execute a Clear Fault to continue operation. 5. If nuisance trips occur at random, but no loss of velocity control can be detected, the value of parameter 724 "ABS Overspeed" may be too low. Decrease the sensitivity of this test by increasing the value of parameter 724 by 10%. Execute a Clear Fault to continue operation.
		 <p>ATTENTION: Do Not execute a Clear Fault without correcting the cause of the fault. This will allow the drive to operate and may cause undesirable operation. The hazard of personal injury or equipment damage exists if faults are not corrected.</p>	

Velocity Processor Faults			
No.	Name	Description	Recovery
VP-13	Motor Field Tolerance (Soft) (Parameter 101 bit 3 when Parameter 630=1)	<p>This fault occurs when the field current feedback is less than 50% of the field current reference for the time specified by the field loss delay period. Internally, parameter 118 "Fld Current Fdbk" and parameter 117 "Fld Current Ref" are compared and if the feedback is less than 50% of the reference, for a time delay specified in parameter 730 "Fld Failure Dly", the fault occurs. A coast stop will be initiated. If Fld Current Fdbk < 50% Fld Current Ref (for delay time); Then fault on VP-13 Motor Field Tolerance.</p> <p>Field loss detection can be disabled by setting Bit 6 of parameter 627 "Flux Mode Select" to 1. This feature could be implemented in applications where external field supplies or permanent magnet motors are used. When Bit 6 is set to a value of 0, field loss detection is active.</p>	<p>The field current to the motor cannot be maintained at the commanded level. The following may have contributed.</p> <ol style="list-style-type: none"> 1. The loss of continuity in the field wiring connections. Check the field connections at the drive, the field connections at the motor, and any connections that may exist in between. 2. Improper values in the field setup parameters. Parameter 612 "Rate Fld Motor Cur" should have the specified motor nameplate rating of the field entered. Parameter 616 "Rated Fld Brdg I" should reflect the field output rating of the particular drive based on the selection of jumper as outlined in the instruction manual. The value of parameter 612 should be less than 616 for proper operation. If it is greater, remove all power and move the jumper to the next higher rated position and enter the corresponding output field bridge rating into parameter 616. 3. Improper connection of the motor field windings. Check the motor manufacturers data sheet concerning proper wiring of the windings in respect to applied voltage and field resistance. Remove all power prior to inspecting or changing field connections. 4. One or more of the Field Supply fuses are open. This is usually annunciated on Series A by a synchronization or phase loss fault. Remove all power prior to checking the continuity of the fuses. Replace blown fuses with the proper rating indicated, before attempting continued operation. 5. A malfunction in the field power structure and control boards. Power down and check the power devices and driver boards following the procedure outlined in the Magnetics/Power Structure section concerning the field components. 6. The input to the field bridge is phase sensitive. Verify L1 & L3 are wired correctly. 7. Change the Main Control Board.

Velocity Processor Faults			
No.	Name	Description	Recovery
VP-14	SCR Overtemp (Selectable) (Parameter 101 bit 4 when Parameter 630=1)	This fault occurs when the thermal switch mounted on the heat sink remains open for 1 time specified by parameter 726. The switch is designed to open above a temperature of 85 degrees C. This fault is type selectable as either Soft or Warning. A Soft Fault selection will cause a controlled stop to be initiated.	<p>The fault is caused by excessive heating of the drive heat sink. Below are a list of things that may have contributed to the occurrence of the fault.</p> <ol style="list-style-type: none"> 1. The ambient air temperature around the drive has exceeded the 60 degrees C rating. Determine the cause of the excessive ambient temperature and correct. Allow the drive to cool prior to executing a Clear Fault and continuing. 2. The failure of cooling fans if the drive is so equipped. Verify that all fans are fully operational and that the air flow to the fans is not obstructed or restricted in any way. Execute a Clear Fault when the heat sink temperature has been reduced to the point where the switch has closed. 3. The output rating of the drive has been exceeded which has caused excessive heat build up in the heat sink. Verify that the drive output rating is correct for the application. Allow the drive to cool and execute a Clear Fault to continue operation. 4. The Heat Sink Thermal switch (HST) or associated circuit malfunction. Remove all power to the drive. Check the connections to the switch which is located in the middle of the heat sink. Check, in a cool ambient, that the switch is closed by measuring the resistance between the two terminals, replace switch if found inoperative. If the fault occurs again replace the Main Control Board. 5. On MkVA & HKVA drives, check the vane switch assembly.
VP-15	External Overtemp (Selectable) (Parameter 101 bit 5 when Parameter 630=1)	This fault occurs when the motor temperature discrete input (TB3-1 & 2) is low for a time greater than specified in parameter 725. This discrete input is usually connected to an internal thermal switch in the motor. It could however be connected to any normally closed switch external to the drive. One second after the switch opens the drive will fault. This fault is type selectable as either Soft or Warning. A Soft Fault selection will cause a controlled stop to be initiated.	Correct the condition which caused the external switch to open. Execute a Clear Fault and continue operation. If this input is not used, connect it to the appropriate control voltage to eliminate Warning Fault occurrences.
VP-16	Thermal Overload Pending (Warning) (Parameter 101 bit 6 when Parameter 630=1)	This fault will be issued any time the average motor armature current exceeds the level specified by 720 "Ovld Pend Level." It is used to indicate that the present armature current output exceeds the level specified by the user and continued operation at this level may cause damage to the motor and/or process. This fault can be disabled. Refer to parameter 632.	<p>No action is required for continued operation. However, depending on the application it may be useful to monitor this fault and take action to reduce the current output when it occurs.</p> <p>Note that a malfunctioning encoder could cause a VP-16 and a VP-39 as well.</p>

Velocity Processor Faults																	
No.	Name	Description	Recovery														
VP-17	Thermal Overload Tripped (Selectable) (Parameter 101 bit 7 when Parameter 630=1)	<p>This fault occurs when the armature current output to the motor exceeds the overload curve characteristics selected by the user in parameter 629 "Mtr Overload Sel". Motor thermal overload protection is based on the square of armature current feedback and the selected overload coefficients. Four different coefficients can be selected through parameter 629, "Mtr Overload Sel"</p> <table border="1"> <thead> <tr> <th>Bit</th> <th>Description</th> </tr> </thead> <tbody> <tr> <td>0</td> <td>Overload function disabled</td> </tr> <tr> <td>1</td> <td>60 seconds to trip at 150% rated motor armature current for externally cooled motors (motors w/ blowers)</td> </tr> <tr> <td>2</td> <td>60 seconds to trip at 200% rated motor armature current for externally cooled motors (motors w/ blowers)</td> </tr> <tr> <td>3</td> <td>60 seconds to trip at 150% rated motor armature current for self cooled motors (motors without blowers)</td> </tr> <tr> <td>4</td> <td>60 seconds to trip at 200% rated motor armature current for self cooled motors (motors without blowers)</td> </tr> </tbody> </table> <p>This is type selectable as Soft or Warning. Soft Fault selection will cause a controlled stop to be initiated.</p>	Bit	Description	0	Overload function disabled	1	60 seconds to trip at 150% rated motor armature current for externally cooled motors (motors w/ blowers)	2	60 seconds to trip at 200% rated motor armature current for externally cooled motors (motors w/ blowers)	3	60 seconds to trip at 150% rated motor armature current for self cooled motors (motors without blowers)	4	60 seconds to trip at 200% rated motor armature current for self cooled motors (motors without blowers)	<ol style="list-style-type: none"> Determine the cause for the increased load which caused excessive armature output to the motor and correct. Execute a Clear Fault and continue operation. Coefficients selected may not match motor thermal characteristics, change overload curve as selected. 		
		Bit	Description														
0	Overload function disabled																
1	60 seconds to trip at 150% rated motor armature current for externally cooled motors (motors w/ blowers)																
2	60 seconds to trip at 200% rated motor armature current for externally cooled motors (motors w/ blowers)																
3	60 seconds to trip at 150% rated motor armature current for self cooled motors (motors without blowers)																
4	60 seconds to trip at 200% rated motor armature current for self cooled motors (motors without blowers)																
VP-18	Motor Stalled (Selectable) (Parameter 101 bit 8 when Parameter 630=1)	<p>Occurs when the armature current output is at current limit and motor velocity is within the zero speed tolerance for a time period greater than the specified time delay. The armature current limit levels are specified in parameters 663 "Fwd Brdg Cur Lim" & 664 "Rev Brdg Cur Lim". The zero speed tolerance level is specified in parameter 710 "Zero Speed Tol" and the delay time in parameter 727 "Stall Delay". Fault is type selectable as Soft or Warning. A Soft Fault selection will cause a coast stop to be initiated.</p>	<p>Determine the cause of stalled condition and correct. Verify the associated parameters are correctly setup. Verify that the field is functioning properly. Without proper field, the torque output may be insufficient even at high armature current levels. Execute a Clear Fault and continue operation.</p>														
VP-19 (cont.)	Contactora Failure (Soft) (Parameter 101 bit 9 when Parameter 630=1)	<p>This fault will occur when it takes 1 second or more for the DC contactor to respond to a command to open or close. It will also occur if the contactor opens or closes without being commanded to do so. A fault occurrence will cause a coast stop to be initiated.</p>	<p>A Contactora Malfunction occurs when the contactor is in a state other than what is being commanded.</p> <ol style="list-style-type: none"> Loss of the contactora power. Check for 115V If not present, check system wiring and correct. Execute a Clear Fault. Check for a loss of continuity between "M1" & "PR" when the contactora is commanded to close. This can be accomplished by verifying that 115V AC is present when the contactora is commanded to close. 115 VAC is measured as shown below. <table border="1"> <thead> <tr> <th>HP</th> <th>115VAC Present</th> </tr> </thead> <tbody> <tr> <td>1-30 HP, 230V AC</td> <td>TB2-6 to TB2-3</td> </tr> <tr> <td>2-60 HP, 460V AC</td> <td>TB2-7 to TB2-3</td> </tr> <tr> <td>40-100 HP, 230V AC</td> <td>TB2-8 to TB2-5 TB2-9 to TB2-5</td> </tr> <tr> <td>75-200 HP, 460V AC</td> <td></td> </tr> <tr> <td>125-300 HP, 230V AC</td> <td>TB5-8 to TB5-5 TB5-9 to TB5-5</td> </tr> <tr> <td>250-600 HP, 460V AC</td> <td></td> </tr> </tbody> </table>	HP	115VAC Present	1-30 HP, 230V AC	TB2-6 to TB2-3	2-60 HP, 460V AC	TB2-7 to TB2-3	40-100 HP, 230V AC	TB2-8 to TB2-5 TB2-9 to TB2-5	75-200 HP, 460V AC		125-300 HP, 230V AC	TB5-8 to TB5-5 TB5-9 to TB5-5	250-600 HP, 460V AC	
HP	115VAC Present																
1-30 HP, 230V AC	TB2-6 to TB2-3																
2-60 HP, 460V AC	TB2-7 to TB2-3																
40-100 HP, 230V AC	TB2-8 to TB2-5 TB2-9 to TB2-5																
75-200 HP, 460V AC																	
125-300 HP, 230V AC	TB5-8 to TB5-5 TB5-9 to TB5-5																
250-600 HP, 460V AC																	

Velocity Processor Faults											
No.	Name	Description	Recovery								
VP-19	Contactor Failure (Soft) (Parameter 101 bit 9 when Parameter 630=1)		<p>3. If external contacts exist between these terminals verify them for proper operation. If an external control of the contactor is not used, be sure a jumper is in place as shown below.</p> <table border="1" style="margin-left: 20px;"> <thead> <tr> <th>HP</th> <th>115VAC Input Connection</th> </tr> </thead> <tbody> <tr> <td>1-30 HP, 230V AC 2-60 HP, 460V AC</td> <td>TB2 - 6 and 7</td> </tr> <tr> <td>40 - 100 HP 230VAC 75 - 200 HP 460VAC</td> <td>TB2 - 8 and 9</td> </tr> <tr> <td>125-300 HP, 230V AC 250-600 HP, 460V AC</td> <td>TB5 - 8 and 9</td> </tr> </tbody> </table> <p>4. An installation or wiring problem with the auxiliary contact block (M1-X) mounted on the DC contactor. Verify that it is properly installed and that the wiring is correctly installed and tight. Vibration due to the opening and closing of the contactor can loosen them so that connection contact is lost.</p> <p>5. A malfunction of the DC contactor (M1). With power removed, verify that nothing is inhibiting the opening or closing of the contactor. Apply power and verify that 115V AC is applied across the coil of the contactor when it is commanded to close. If it is present, but the contactor does not close, then replace the DC Contactor.</p> <p>6. A malfunction of the Pilot Relay (PR). If no voltage was present across the contactor coil when commanded to close then verify that 115V AC is present across J1p1 and 2 on the PSI Board for Series A Drives (SP1-1 and 2 for Series B). If it is present, then check the wiring that goes to the Pilot Relay. If all is in order then replace the Pilot Relay.</p> <p>7. A malfunction of the Power Stage Interface Board (PSI). If no voltage was present across J1p1 and 2 on Series A (SP1-1 and 2 on Series B) when the contactor is commanded to close and the fault still occurs, then replace the PSI Board.</p> <p>8. A malfunction on the Main Control Board. If after replacing the PSI Board the "Contactor Malfunction" fault still occurs then replace the Main Control Board.</p>	HP	115VAC Input Connection	1-30 HP, 230V AC 2-60 HP, 460V AC	TB2 - 6 and 7	40 - 100 HP 230VAC 75 - 200 HP 460VAC	TB2 - 8 and 9	125-300 HP, 230V AC 250-600 HP, 460V AC	TB5 - 8 and 9
HP	115VAC Input Connection										
1-30 HP, 230V AC 2-60 HP, 460V AC	TB2 - 6 and 7										
40 - 100 HP 230VAC 75 - 200 HP 460VAC	TB2 - 8 and 9										
125-300 HP, 230V AC 250-600 HP, 460V AC	TB5 - 8 and 9										
VP-20	AC Voltage (Selectable) (Parameter 101 bit 10 when Parameter 630=1)	This fault occurs when the incoming AC line voltage deviates by more than +15% or -20% of the level specified in parameter 617 "Rated AC Line" for a time period greater than Param 728. This fault is type selectable as either Soft or Warning. A Soft Fault selection will cause a controlled stop to be initiated.	<p>1. Verify and correct the cause of the AC line voltage variance. If no variances can be detected, measure the RMS line voltage during worse case motor load conditions. If the line voltage drops significantly under load, the voltage source kVA output may be insufficient for the application. Execute a Clear Fault to continue operation.</p> <p>2. Verify RMS Line to Line value read with DVM to value reported by Param 116. Adjust Param 740 as required.</p>								
VP-21	Handshake With SP (Hard) (Parameter 101 bit 11 when Parameter 630=1)	Internal communication between processors has malfunctioned. A coast stop will be initiated.	Execute System RESET or cycle power and attempt normal operation. If the fault reoccurs, replace Main Control Board.								

Velocity Processor Faults			
No.	Name	Description	Recovery
VP-22	Handshake With CP (Hard) (Parameter 101 bit 12 when Parameter 630=1)	Internal communication between processors has malfunctioned. A coast stop will be initiated.	Execute System RESET or cycle power and attempt normal operation. If the malfunction reoccurs, replace Main Control Board.
VP-23	SP Mode Request Not Honored (Hard) (Parameter 101 bit 13 when Parameter 630=1)	Internal communication between processors has malfunctioned. A coast stop will be initiated.	Execute System RESET or cycle power and attempt normal operation. If the malfunction reoccurs, replace Main Control Board.
VP-24	CP Not In VP Requested Mode (Hard) (Parameter 101 bit 14 when Parameter 630=1) Velocity Processor Faults	Internal communication between processors has malfunctioned. A coast stop will be initiated.	Execute System RESET or cycle power and attempt normal operation. If the malfunction reoccurs, replace Main Control Board.

Faults VP-31 through VP-39 are reported in parameter 101 “Drive Fault” when parameter 630 “Fault Report” is set to a value of 0. The bit assignments for parameter 101 are given in () where applicable. See Fault Type Selection.

Velocity Processor Faults			
No.	Name	Description	Recovery
VP-31	Arm Bridge Overload Trip (Selectable) (Parameter 101 bit 5 when Parameter 630=0) Current Processor Faults	This fault occurs when the armature current output exceeds the predetermined overload curve characteristics. Armature bridge thermal overload protection is based on an inverse time, armature current product. The coefficients are based on 150% for 60 seconds, 200% for 10 seconds, and 260% of armature bridge rating for 5 seconds. This fault is type selectable as either Soft or Warning. A Soft Fault selection will cause a controlled stop to be initiated.	Determine the cause of the increased load, which resulted in excessive armature current output, and correct. Verify that the field is functioning properly. Without proper field, the torque output may be insufficient even at high armature current levels. Verify that the drive and motor is properly sized for the application. Execute a Clear Fault and continue operation.

Velocity Processor Faults																								
No.	Name	Description	Recovery																					
VP-32	Motor Field Loss (Parameter 101 bit 6 when Parameter 630=0)	This fault occurs if the field current reference (parameter 117) is greater than the field current threshold (parameter 729) and the field current feedback (parameter 118) is less than 10% of the threshold.	<p>The field current to the motor cannot be maintained at the commanded level. Below are a list of things that may have contributed to the occurrence of the fault.</p> <ol style="list-style-type: none"> The loss of continuity in the field wiring connections. Check the terminals as outlined in the following table. The field connections at the motor and any connections that may exist in between. <p>Motor Field Connections (CCW Rotation)</p> <table border="1"> <thead> <tr> <th>Drive</th> <th>Drive Terminal Connection</th> <th>Motor Lead</th> </tr> </thead> <tbody> <tr> <td>1-30 HP, 230V AC</td> <td>TB1-3</td> <td>F1 (+)</td> </tr> <tr> <td>2-60 HP, 460V AC</td> <td>TB1-4</td> <td>F2 (-)</td> </tr> <tr> <td>40 - 100 HP 230VAC</td> <td>TB2-</td> <td>F1 (+)</td> </tr> <tr> <td>75 - 200 HP 460VAC</td> <td>TB2-2</td> <td>F2 (-)</td> </tr> <tr> <td>125-300 HP, 230V AC</td> <td>TB7-1</td> <td>F1 (+)</td> </tr> <tr> <td>250-600 HP, 460V AC</td> <td>TB7-3</td> <td>F2 (-)</td> </tr> </tbody> </table> <ol style="list-style-type: none"> Improper values in the field setup parameters. Parameter 612 "Rate Fld Motor Cur" should have the specified motor nameplate rating of the field entered. Parameter 616 "Rated Fld Brdg I" should reflect the field output rating of the particular drive based on the selection of jumper J1 for field current selection. The value of parameter 612 should be less than parameter 616 for proper operation. If it is greater, remove all power and move the jumper to the next higher rated position and enter the corresponding output field bridge rating into parameter 616. 	Drive	Drive Terminal Connection	Motor Lead	1-30 HP, 230V AC	TB1-3	F1 (+)	2-60 HP, 460V AC	TB1-4	F2 (-)	40 - 100 HP 230VAC	TB2-	F1 (+)	75 - 200 HP 460VAC	TB2-2	F2 (-)	125-300 HP, 230V AC	TB7-1	F1 (+)	250-600 HP, 460V AC	TB7-3	F2 (-)
Drive	Drive Terminal Connection	Motor Lead																						
1-30 HP, 230V AC	TB1-3	F1 (+)																						
2-60 HP, 460V AC	TB1-4	F2 (-)																						
40 - 100 HP 230VAC	TB2-	F1 (+)																						
75 - 200 HP 460VAC	TB2-2	F2 (-)																						
125-300 HP, 230V AC	TB7-1	F1 (+)																						
250-600 HP, 460V AC	TB7-3	F2 (-)																						
VP-34	Waiting Safe Arm Voltage (Selectable) (Parameter 101 bit 8 when Parameter 630=0)	Fault occurs when the armature CEMF is too high to allow successful commutation during a forward to reverse bridge change. If Soft Fault is selected then a fault occurrence will cause a coast stop. If a Warning Fault is selected then an occurrence will cause the motoring bridge to be held off, allowing the motor to coast to a lower CEMF, when an acceptable level is reached, the drive will allow a bridge change and operation will continue.	Determine the cause for the excessive armature CEMF and correct. It may be due to incorrect field control setup. This can especially be true when this fault occurs during operation above base speed when the drive is in Field Weakening mode and the Field Flux Table Set-up was improperly calibrated. Review the Start-up Procedure and verify that all parameters are properly entered and that the calibration parameters were properly setup. Execute a Clear Fault to continue operation.																					
VP-35	Waiting Zero Arm Current (Selectable) (Parameter 101 bit 9 when Parameter 630=0)	This fault occurs when the armature current does not go to zero when a bridge change is commanded. If Soft Fault is selected then a fault occurrence will cause a coast stop. If a Warning Fault is selected then an occurrence will cause the drive to continue to attempt to force the current to zero. When zero current is achieved the drive will allow a bridge change and operation will continue.	<p>Verify that the armature current loop was properly tuned following the procedure outlined in the chapter on Start-Up Procedures. Execute a Clear Fault to continue operation.</p> <p>Note that a malfunctioning encoder could cause a VP-35.</p>																					
VP-36	Excess Arm Voltage (Warning) (Parameter 101 bit 10 when Parameter 630=0)	This Warning occurs when the CEMF of the motor is too high to allow more armature current to be generated. It is used to indicate that the armature firing angle is at it's end stop and cannot be phased forward anymore. The level of armature current cannot be increased until the CEMF is reduced. This Warning may occur if the incoming line voltage is low, or excessive CEMF exists due to improper field weakening control or excessive speed.	<p>No action is required for continued operation. It may be advantageous to determine the cause for the high armature current demand at high armature voltage.</p> <ol style="list-style-type: none"> Check status of parameter 627, bit 7 (no flux compensation). Verify the flux table is correct. Check encoder signals. <p>Note: This warning fault can be disabled. Refer to parameter 632.</p>																					

Velocity Processor Faults			
No.	Name	Description	Recovery
VP-39	Arm Bridge Overload Pending (Warning) (Parameter 101 bit 13 when Parameter 630=0)	This Warning will be issued any time the average armature current exceeds 105% of the nameplate rating of the armature bridge as specified in parameter 615 "Rated Arm Brdg I". It is used to indicate that the present armature current output exceeds a predetermined level and continued operation at this level may cause an Armature Overload Trip (VP-31).	No action is required for continued operation. However, depending on the user's application it may be useful to monitor this malfunction and take action to reduce the current output when it occurs. 1. Check encoder signals.
VP-40	Autotune Status Fault (Soft)	Internal processor error detected during Autotune. A coast stop will be initiated.	Execute a Clear Fault and attempt normal operation. If the fault reoccurs, replace Main Control Board.
VP-41	Autotune Logic State (Soft)	Internal processor error detected during Autotune. A coast stop will be initiated.	Execute a Clear Fault and attempt normal operation. If the fault reoccurs, replace Main Control Board.
VP-42	Invalid Feedback Device	No feedback device or incorrect feedback device selected.	A feedback device must be selected in parameter 621.
VP-43	Invalid Taper Speed (Soft)	The speed programmed in parameter 665 "Start Taper Speed" is less than the speed programmed in parameter 699 "Autotune Speed". The taper speed would have interfered with the Autotune measurements and the drive faulted as a result.	Program parameter 665 "Start Taper Speed" to a value greater than parameter 699 "Autotune Speed". Execute a Clear Fault and attempt normal operation.
VP-44	Invalid Torque Mode (Soft)	The torque mode programmed in Parameter 625 "Torque Mode" is incorrect for the commanded Autotune function. The selected torque mode must be "1-Velocity Regulate" to perform the VP measure function.	Select the proper torque mode in Parameter 625 "Torque Mode". Execute CLEAR FAULTS and attempt normal operation.
VP-45	Autotune Start Timeout (Soft)	If the Autotune measure function is commanded and the user does not initiate a START command within 30 seconds, the drive will fault. This guards against the possibility of the drive being left unattended in the Autotune command state.	Execute a Clear Fault. The drive is then available for normal operation or the Autotune measure function.
VP-46	Excess Motor Rotation (Soft)	The motor shaft moved beyond the allowed rotation tolerance during the CP measure function. This indicates that residual flux in the motor allowed torque to be produced during the armature measurement.	Execute a Clear Fault and attempt the procedure again with the motor shaft mechanically locked.
VP-47	CP Not In Autotune Mode (Soft)	The CP is not responding to the Autotune request issued from the VP. Internal communication between processors has malfunctioned.	Execute a Clear Fault and attempt normal operation. If the fault reoccurs, replace Main Control Board.
VP-48	Motor Not Up To Speed (Soft)	The Motor velocity has deviated from the programmed Autotune Speed as specified in parameter 699 "Autotune Speed" during the Field Flux Measure function. The tolerance is programmed through parameter 709 "Up To Speed Tolerance". The Motor velocity must be at the programmed level before executing the Field Flux Measure.	Determine why the velocity dropped during the measure function. It may be due to an excessive load present during the Field Flux Measure. The available torque is reduced and it may be necessary to un-couple the load to perform this measurement. The tolerance may be increased by increasing the value programmed at parameter 709. Execute a Clear Fault and attempt normal operation.

Velocity Processor Faults			
No.	Name	Description	Recovery
VP-49	CEMF Unstable (Soft)	The measured CEMF did not stabilize during a Field Flux measurement. The CEMF must be stable in 2 seconds after an adjustment of the field current.	Execute a Clear Fault and attempt normal operation. If the fault reoccurs, verify that the actual velocity is remaining relatively constant. This fault can be caused by varying speed, varying loads which results in armature reaction, or incorrect CEMF regulator gains (parameters 672,673), all which can cause the CEMF to vary. It can also be caused by having parameter 610 "Rated Motor Volt" incorrectly set-up. Programmed Rated Motor voltage must be achieved for proper operation. Check Parameters 612 & 616. Parameter 612 must equal rated field from motor nameplate, and Param 616 value should be taken from Table 8-J of the Installation Manual.
VP-50	Profile Timeout	Velocity loop Autotune profile did not complete within 5 minutes.	Motor or system inertia too great, parameter 698 too low. Execute a Clear Fault and reattempt Autotune.
VP-51	No Current Limit on Accel	Autotune velocity test failed on the accel portion of the profile.	Autotune current limit (parameter 698) was not reached. Verify Current Loop Tune was done prior to velocity loop. Parameter 698 may have too high a value or parameter 699 may be too low. Clear faults and reattempt Autotune.
VP-52	No Current Limit on Decel	Autotune velocity test failed on the decel portion of the profile.	Current limit (parameter 698) was not reached. Verify Current Loop Tune was done prior to velocity loop. Parameter 698 may have too high a value or parameter 699 may be too low. Clear faults and reattempt Autotune.
VP-53	Contactors Control	Autotune for current loop was aborted due to contactor closed or contactor forced open.	Assure that ECOAST is NOT open and contactor is not closed. Reset faults and try again.

Current Processor Faults (CP-XX)

The Current Processor is responsible for fault monitoring of the armature and field bridges in the drive. This includes monitoring the armature and field currents to the motor, power components, incoming line synchronization, and communications to the Velocity Processor. These faults can be induced by problems external to the immediate drive such as incoming AC line variations, motor malfunction, etc. An attempt to identify and correct these conditions, if applicable, must be done prior to replacing components in the drive. Internal drive malfunctions are also monitored such as bridge component malfunctions, excessive currents, loss of power supplies, etc. These faults will try to indicate the cause of the problem so that it can be corrected.

A test of the armature bridge components is made every time the power is cycled or the drive is RESET. This testing will alert the user to a shorted bridge component prior the start of normal operation, minimizing the possibility of further damage. A more comprehensive armature bridge test is performed during Autotune. This test verifies conduction capability as well as shorted or open power devices.

Internal processor faults that occur can be induced by Electrostatic Discharge (ESD), Electromagnetic Interference (EMI), excessive heat, contamination of printed circuit boards (PCB), improper connector connections, etc. An attempt should be made to correct any of these environmental conditions prior to replacing components in the drive. This can help reduce the possibility of recurrence. If board replacement is necessary, replace the board and any EPROMS that may reside on the board.

Current Processor Faults			
No.	Name	Description	Recovery
CP-01	Three-Phase Power Not On		
CP-02	Bckgnd Scheduler Fault (Hard)	Internal processor error detected. A coast stop will be initiated.	Execute SYSTEM RESET or cycle power and attempt normal operation. If the fault reoccurs, replace Main Control Board.
CP-04	Interrupt Timeout (Hard)	Internal processor error detected. A coast stop will be initiated.	Execute SYSTEM RESET or cycle power and attempt normal operation. If the fault reoccurs, replace Main Control Board.
CP-05	Logic Power Supply Loss (Soft) (Parameter 101 bit 1 when Parameter 630=0)	The 5V logic or 12V logic power supply has been detected as being out of tolerance. A coast stop will be initiated.	Use a digital multimeter to measure the +5V logic supply from TP51 (+5V) to TP52 (DGND) on the Main Control Board. If the supply is not within a 0.15V tolerance replace the unit Power Supply. Likewise test the 12V supplies The +12V supply can be measured from TP55 (+12V) to TP57 (AGND). The -12V supply can be measured from TP56 (-12V) to TP57. If either supply is not within the tolerance listed in Table 3.C then replace the unit Power Supply. If power supplies are OK, replace the Main Control Board.

Current Processor Faults			
No.	Name	Description	Recovery
CP-06	Phase Loss (Soft) (Parameter 101 bit 0 when Parameter 630=0)	The drive has detected that one or more of the incoming three-phase AC lines is open. A coast stop will be initiated.	<p>Below are a list of conditions that may have contributed to the occurrence of the fault.</p> <ol style="list-style-type: none"> 1. The loss of a phase from the source. To verify this, measure the AC voltage present at the incoming fuses. Measure line 1 to 2, line 2 to 3, and line 1 to 3 on the incoming side of the protection device to determine which if any phases are missing. Correct the condition before attempting continued operation. 2. One or more of the main protection fuses (F1-F3) are open. Remove all power prior to checking the continuity of the fuses. Reset the circuit breaker or replace the blown fuses, with the proper rating and type as indicated, before attempting continued operation. 3. One or more of the Field Supply Fuses are open. Remove all power prior to checking the continuity of the fuses. Check the field SCRs. Replace the blown fuses with the proper rating and type indicated, before attempting continued operation. (Applicable to Series A only). 4. Execute a CLEAR FAULTS to continue operation. If the fault reoccurs a transient condition may be present in the incoming AC line. Monitor the AC lines for excessive line notches or other transients. If the fault reoccurs and no transients exist, replace the Main Control Board. If the fault reoccurs replace the Feedback Board. 5. In some instances, one of the AC line voltages may be lost at the source, however this may be difficult to detect due to other three-phase equipment operating on the same source. The missing line may be generated by an AC motor operating on the same source. Under no load conditions the voltage may appear normal but then the line may collapse once the current draw is increased. A motor as small as a three-phase blower motor mounted on the DC motor can produce the missing phase until a load is placed on the AC line. 6. Check the PE & TE grounding. Determine if the XO connection on the isolation transformer is grounded.
CP-07	Overcurrent Trip (Soft) (Parameter 101 bit 4 when Parameter 630=0)	This fault occurs when approximately 4 times rated armature bridge current occurs in either the incoming AC lines or the DC connections to the motor. This over current condition indicates that excessive current is flowing in the power structure. Verify correct burden resistors. A coast stop is initiated.	<p>Execute a SYSTEM RESET to initiate a Armature Bridge power-up test which will test for shorted power devices. An indication will be made if any component malfunction is detected. If none is indicated:</p> <ol style="list-style-type: none"> 1. Initiate normal operation. If the fault reoccurs, check the current regulator gains for proper set-up. If the gains are in question execute the Current loop tuning procedure described under <i>Autotune</i>. 2. Execute a CLEAR FAULT, if the fault reoccurs, a malfunction exists in the power structure or the motor. Refer to the Magnetics/Power Structure section of this manual for further details. 3. If this fault reoccurs at high speed, verify that the motor commutation limit, based on the velocity and armature current levels of the motor, has not been exceeded.

Current Processor Faults			
No.	Name	Description	Recovery
CP-08	AC Overcurrent Trip (Soft) (Parameter 101 bit 2 when Parameter 630=0)	This fault occurs when approximately 4 times rated armature bridge current occurs in the incoming AC lines. Verify correct burden resistors. It is detected by the Current Transformers which monitor the AC lines. An over current condition indicates that excessive current is flowing in the power structure. This type of overcurrent fault is usually caused by a bridge misfire or loss of firing control. A coast stop is initiated.	Execute a SYSTEM RESET to initiate an Armature Bridge power-up test which will test for shorted power devices. An indication will be made if any component malfunction is detected. If none is indicated: 1. Initiate normal operation. If the fault reoccurs, check the current regulator gains for proper set-up. If the gains are in question execute the Current loop tuning procedure described under <i>Autotune</i> . 2. Execute a CLEAR FAULT, if the fault reoccurs, a malfunction exists in the power structure or the motor. Refer to the Magnetics/Power Structure section for further details.
CP-09	DC Overcurrent Trip (Soft) {3.6 to 345 Amp Bridge Only} (Parameter 101 bit 3 when Parameter 630=0)	This fault occurs when approximately 4 times rated armature bridge current occurs in the DC connections to the motor. It is detected by a DC transducer which monitors the DC link. An overcurrent condition indicates that excessive current is flowing in the power structure. This type of overcurrent fault usually indicates that a bridge misfire or motor commutator flashover has occurred. A coast stop is initiated.	Execute a SYSTEM RESET to initiate a Armature Bridge power-up test which will test for shorted power devices. An indication will be made if any component failure is detected. If none is indicated: 1. Initiate normal operation. If the fault reoccurs, check the current regulator gains for proper set-up. If the gains are in question execute the Current loop tuning procedure described under <i>Autotune</i> . 2. Execute a CLEAR FAULT, if the fault reoccurs, a malfunction exists in the power structure or the motor. Refer to the Magnetics/Power Structure section of this chapter for further details.
CP-11	Zero Cross Chann (Soft)	Internal hardware error detected. A coast stop will be initiated.	Execute a SYSTEM RESET or cycle power and attempt normal operation. If the fault reoccurs, replace Main Control Board.
CP-13	Sync Loss (Soft)	Ten consecutive failures to synchronize to the incoming AC lines has occurred. During normal operation the Current Processor (CP) synchronizes its firing to the crossing of the AC line waveform. This fault can be generated by the following problems: 1. The AC line period varied by more than 0.46ms since the last measurement. 2. The synchronization origin for the SCR firing calculations varied by more than 0.46 ms from the last calculated value. 3. An AC line zero crossing was not detected. 4. Multiple AC line crossings were detected. If a synchronization malfunctions, the CP will fire on the estimated crossing for up to ten consecutive cycles. After ten, the fault occurs and the drive will initiate a coast stop.	A loss of synchronization is usually linked to variations in the AC line frequency or excessive noise on the AC lines due to line notches or other transient conditions. These conditions must be checked and corrected. Execute a CLEAR FAULT and continue operation. If the fault reoccurs and the AC lines are stable and relatively free from noise or transients replace the Main Control Board.
CP-14	Field Origin (Soft)	An internal hardware error that initiates a coast stop.	Execute a SYSTEM RESET or cycle power and attempt normal operation. If the fault reoccurs replace the Main Control Board.

Current Processor Faults			
No.	Name	Description	Recovery
CP-15	24V Power Supply Loss (Soft)	<p>The 24V power supply was detected at a level below 18V. This will initiate a coast stop. The 24V power supply is used to supply the gate firing circuits and the 24V ECOAST circuitry.</p> <p>Note: If a constant voltage transformer is used to supply control power, verify that the output is not a distorted sine wave. A distorted sine wave could result in the DC switching power supply to generate a CP-15.</p>	<ol style="list-style-type: none"> 1. Verify that the 24V power supply is low by measuring the voltage between TP5 (+24V) and TP23 (common) on the Power Stage Interface (PSI) Board for Series A (measure between TP 25 and TP6 on the PSI Switcher board for Series B). If it is zero, remove all power and check F7 for continuity. Replace the fuse, if blown, with the proper rating indicated. 2. If the fault still occurs but the fuse is good, verify that the 24V ECOAST circuit external to the drive is not shorting out the supply. 3. If the voltage at the test points is correct, execute a CLEAR FAULT and continue operation. If the fault reoccurs replace the Main Control Board. 4. If the Fault reoccurs and the fuse was good, but there is no voltage across the test points, check that approximately 20Vrms is present from the cathode of D8 to the cathode of D7 on the PSI Board. If it is incorrect, then the transformer 1PT has failed, and factory repair is necessary. If it is correct, then power down and replace the PSI Board. 5. If the fault reoccurs after all of the above, then refer to the Magnetics/Power Structure section for details on checking the Pulse Snubber Boards.
CP-16	Autotune Fault (Soft)	This fault occurs when an internal error is detected during the Autotune execution. Autotune will be aborted.	Execute a CLEAR FAULT and attempt normal operation. If the fault reoccurs, replace Main Control Board.
CP-17	Overcurrent Reset Fault (Soft)	Internal hardware error detected. A coast stop will be initiated.	Execute a CLEAR FAULTS and attempt normal operation. If the fault reoccurs, replace Main Control Board.

Current Processor Faults			
No.	Name	Description	Recovery
CP-18	Arm Current Unbalanced (Soft)	This fault indicates that the Armature current has excessive ripple content. A coast stop will be initiated.	<p>Below are a list of conditions that may have contributed to the occurrence of the fault.</p> <ol style="list-style-type: none"> 1. Could be caused by excessive high current loop gains 2. The excessive ripple content could be due to an imbalance in the three-phase incoming voltage supply. Verify the condition of the isolation transformer and the terminal connections. Monitor the incoming three-phase voltage and if an imbalance is observed correct it before attempting to continue. Execute a CLEAR FAULT to resume operation. 3. The pulse driver circuitry may have malfunctioned and one or more SCRs may not be firing when commanded. Verify that all gate leads are connected and all six SCR pairs are operating correctly by executing the Current Loop Test under the Autotune. See the Autotune description in Chapter 5 for more details. If a failure is indicated refer to the Magnetics/Power Structure section of this chapter. 4. Verify that the CTs have been installed properly. Check the motor for loose brush holders. Megger the motor armature to ground, field to ground and armature to field. 5. A loss of one of the 3 phase lines has occurred. This may not be detected as a phase loss due to other machines or equipment operating on the same lines, but will be detected as an imbalance. Verify that all incoming lines are present and at the proper level. Execute a CLEAR FAULTS to resume operation. 6. A faulty DC tach or encoder.
CP-19	Short CKT Through Bridge (Soft)	This fault occurs if the armature current exceeds 25% of the maximum armature bridge for a period of 90 AC line cycles (1.5 seconds) while the contactor is open and the armature bridge is disabled.	Check for shorted SCRs, and execute a SYSTEM RESET.
CP-31	Integrate Reset (Hard)	Internal hardware error detected. A coast stop will be initiated.	Execute a SYSTEM RESET or cycle power and attempt normal operation. If the fault reoccurs, replace Main Control Board.
CP-32	A/D Timeout (Soft)	Internal hardware error detected. A coast stop will be initiated.	Execute a CLEAR FAULT and attempt normal operation. If the fault reoccurs, replace Main Control Board.
CP-33	A/D Busy (Soft)	Internal hardware error detected. A coast stop will be initiated.	Execute a CLEAR FAULT and attempt normal operation. If the fault reoccurs, replace Main Control Board.
CP-34	End Stop Timing (Soft)	Internal hardware error detected. A coast stop will be initiated.	Execute a CLEAR FAULT and attempt normal operation. If the fault reoccurs, replace Main Control Board.
CP-35	System Tripped (Soft)	Internal hardware error or fault condition detected. A coast stop will be initiated.	Check the Fault Queue for any additional faults indicated. Correct any and all fault conditions present. Execute a CLEAR FAULT and attempt normal operation. If the fault reoccurs, replace Main Control Board.
CP-40	FIFO Flush (Soft)	Internal processor error detected. A coast stop will be initiated.	Execute a CLEAR FAULT and attempt normal operation. If the fault reoccurs, replace Main Control Board.

Current Processor Faults			
No.	Name	Description	Recovery
CP-41	CAM Full (Soft)	Internal processor error detected. A coast stop will be initiated. 1. A loss of one of the 3 phase lines has occurred. This may not be detected as a phase loss due to other machines or equipment operating on the same lines, but will be detected as an imbalance. Verify that all incoming lines are present and at the proper level. Execute a Clear Fault to resume operation.	Execute a CLEAR FAULT and attempt normal operation. If the fault reoccurs, replace Main Control Board.
CP-42	FIFO Overflow (Soft)	Internal processor error detected. A coast stop will be initiated.	Execute a CLEAR FAULT and attempt normal operation. If the fault reoccurs, replace Main Control Board.
CP-43	FIFO Empty (Soft)	Internal processor error detected. A coast stop will be initiated.	Execute a CLEAR FAULT and attempt normal operation. If the fault reoccurs, replace Main Control Board.
CP-46	Too Many Pos Xing (Soft)	This fault indicates that too many positive AC line zero crossings have been detected. This is usually a result of noisy AC lines. A coast stop will be initiated.	Monitor the incoming AC lines for excessive noise and transients. If the lines are stable and free from noise, execute a CLEAR FAULT and continue operation. If the fault reoccurs replace the Main Control Board.
CP-47	Positive Xing (Soft)	This fault indicates that an incorrect positive AC line crossing has been detected. This is usually a result of noisy AC lines. A coast stop will be initiated.	Monitor the incoming AC lines for excessive noise and transients. If the lines are stable and free from noise, execute a CLEAR FAULT and continue operation. If the fault reoccurs replace the Main Control Board.
CP-48	Too Many Neg Xing (Soft)	This fault indicates that too many negative AC line zero crossings have been detected. This is usually a result of noisy AC lines. A coast stop will be initiated.	Monitor the incoming AC lines for excessive noise and transients. If the lines are stable and free from noise, execute a CLEAR FAULT and continue operation. If the fault reoccurs replace the Main Control Board.
CP-49	Negative Xing (Soft)	This fault indicates that an incorrect negative AC line crossing has been detected. This is usually a result of noisy AC lines. A coast stop will be initiated.	Monitor the incoming AC lines for excessive noise and transients. If the lines are stable and free from noise, execute a CLEAR FAULT and continue operation. If the fault reoccurs replace the Main Control Board.
CP-50	RX Msg Index (Warning)	Internal processor error was detected and corrected. Operation is unaffected.	No action is required.
CP-52	No Msg Ready (Warning)	Internal processor error was detected and corrected. Operation is unaffected.	No action is required.
CP-58	Illegal Mode Seq (Soft)	Internal processor error detected. A coast stop will be initiated.	Execute a CLEAR FAULT and attempt normal operation. If the fault reoccurs, replace Main Control Board.
CP-60	Phase Missed (Soft)	Detection of the AC line zero crossing was missed. This is usually a result of noisy AC lines. A coast stop will be initiated.	Verify connections in the power structure. Monitor the incoming AC lines for excessive noise and transients. If the lines are stable and relatively free from noise, execute a CLEAR FAULT and continue operation. Check system grounding. If the fault reoccurs replace the PSI Board first, then the Main Control Board.
CP-61	Period Variation (Soft)	The period of the incoming AC lines varied by more than 0.40ms during power-up synchronization. This indicates that the AC line frequency is varying by more than 2Hz. A coast stop will be initiated.	Check the AC lines for frequency variations and correct the cause. If the line frequency is stable and free from noise, execute a CLEAR FAULT and continue operation. If the fault reoccurs, replace the Main Control Board.
CP-62	Period Limit (Soft)	The period of the incoming AC lines is out of tolerance during power-up synchronization. This indicates that the AC line frequency is outside the 45-65Hz operating range. A coast stop will be initiated.	Measure the AC line frequency and correct the cause if out of tolerance. If the line frequency is within the operating range and is free from noise, execute a CLEAR FAULT and continue operation. If the fault reoccurs replace the Main Control Board.
CP-63	Fire Delay (Soft)	Internal hardware error detected. A coast stop will be initiated.	Execute a CLEAR FAULT and attempt normal operation. If the fault reoccurs, replace Main Control Board.

Current Processor Faults			
No.	Name	Description	Recovery
CP-65	Phase Out of Spec (Soft)	The incoming three-phase AC lines do not have the correct 120 degrees phase relationship between them. A coast stop will be initiated.	Check the phase relationships of the AC lines. Verify that they are 120 degrees out of phase and are stable and free from noise. If they appear correct execute a CLEAR FAULT and attempt normal operation. If the fault reoccurs, replace Main Control Board.
CP-66	Firing Sequence (Soft)	Internal hardware error detected. A coast stop will be initiated.	Execute a CLEAR FAULT and attempt normal operation. If the fault reoccurs, replace Main Control Board.
CP-90	SCR Test Arm Voltage (Soft)	This fault indicates that excessive armature voltage existed prior to execution of the SCR test routine. The test was aborted due to the possibility of excessive armature currents being produced during the tests.	This fault usually indicates that excessive armature voltage existed due to motor rotation prior to the test. Before executing a SYSTEM RESET or cycling power, the motor should be brought to rest (zero velocity). After the motor comes to rest, execute a SYSTEM RESET and continue operation. If the fault reoccurs, measure the armature voltage at A1 and A2 on the DC contactor. If the voltage is less than 60V for 150-300V AC drive, or 120V for 300-460V AC drive, and the fault reoccurs, replace Main Control Board.
CP-91	SCR Test Arm Current (Soft)	This fault indicates that excessive armature current existed prior to execution of the SCR test routine. The test was aborted.	This fault indicates an internal hardware error. Execute a Clear Fault and attempt normal operation. If the fault reoccurs, replace Main Control Board.
CP-92	SCR Test Aborted (Soft)	While testing for open SCR's an abort request or STOP command was received. The test was aborted.	Execute a CLEAR FAULT and attempt normal operation.
CP-93	SCR Test ECOAST (Soft)	This fault occurs if the ECOAST input is opened while the SCR check is being done.	Close ECOAST input, execute a CLEAR FAULT and attempt normal operation.
CP-94	Armature Voltage Reversed (Soft)	The open SCR test detected that the internal armature voltage sense circuit has the wrong polarity due to an internal wiring problem.	The armature bridge voltage sense polarity is checked during the maximum discontinuous current test. The armature bridge voltage is measured repeatedly for 15 degrees after an SCR pair is fired to check if the armature voltage is the correct polarity. The measured armature voltage has to exceed a nominal voltage ($\pm 25V$) and be positive (negative) when the forward (reverse) bridge is selected for at least three samples. Otherwise there is a hardware problem and fault CP-94, Armature Voltage Reversed is reported. Contact Factory Service Technician, to repair internal wiring problem.
CP-96	AC Line Unbalance (Soft)	This fault indicates that the three phases of AC line voltage were detected as unbalanced during the Autotune function. Armature current ripple exceeded 12.5% of FLA of the motor. A 10% line voltage imbalance between phases is the maximum allowed.	If the maximum discontinuous current test was executed successfully, the current balance test is executed. The mean current of the last six current pulses from the maximum discontinuous current test is used to determine if the AC line is balanced. If the minimum and maximum current pulses are less than 1%, then fault CP-97 Line Balance Test is reported. And if the difference between the minimum and maximum current pulses vary by more than 12.5% of full load current, then fault CP-96 is reported. The fault is due to an imbalance in the three-phase incoming voltage supply. Monitor the incoming three-phase voltage and if an imbalance is observed prior to/or during normal operation, correct it before attempting to continue. Execute a CLEAR FAULT to resume operation.
CP-97	Line Balance Test (Soft)	This fault indicates an internal error was detected during the AC Line Balance test.	Execute a CLEAR FAULT and attempt normal operation. If the fault reoccurs, replace Main Control Board.

Current Processor Faults			
No.	Name	Description	Recovery
CP-98	SCR Field Cur Low (Soft)	During the SCR test routine, the field current is enabled before the maximum discontinuous current measurement. This fault occurs if the field current feedback is not within 6.25% of the field current reference after 180V AC line cycles.	Refer to VP-13 Motor Field Loss fault.
CP-100	SCR Test Fault (Soft)	An internal hardware error detected during the SCR test. The power-on test was aborted.	Execute a CLEAR FAULT and attempt normal operation. If this is a very low current drive, manually tune the drive. Incorrect Burden Resistors can also cause this malfunction. Verify CT turns. On some applications of high inductance motors, manual tuning may be necessary. If the fault reoccurs, replace Main Control Board.
CP-101	SCR #1F or #4R Shorted (Soft)	This fault is a result of a malfunction detected during the SCR test. It indicates that either the #1 SCR of the forward armature bridge or the #4 SCR of the reverse bridge is shorted.	Refer to the Magnetics/Power Structure section for further details on correcting armature bridge failures.
CP-102	SCR #2F or #5R Shorted (Soft)	This fault is a result of a malfunction detected during the SCR test. It indicates that either the #2 SCR of the forward armature bridge or the #5 SCR of the reverse bridge is shorted.	Refer to the Magnetics/Power Structure section for further details on correcting armature bridge failures.
CP-103	SCR #3F or #6R Shorted (Soft)	This fault is a result of a malfunction detected during the SCR test. It indicates that either the #3 SCR of the forward armature bridge or the #6 SCR of the reverse bridge is shorted.	Refer to the Magnetics/Power Structure section for further details on correcting armature bridge failures.
CP-104	SCR #4F or #1R Shorted (Soft)	This fault is a result of a malfunction detected during the SCR test. It indicates that either the #4 SCR of the forward armature bridge or the #1 SCR of the reverse bridge is shorted.	Refer to the Magnetics/Power Structure section for further details on correcting armature bridge failures.
CP-105	SCR #5F or #2R Shorted (Soft)	This fault is a result of a malfunction detected during the SCR test. It indicates that either the #5 SCR of the forward armature bridge or the #2 SCR of the reverse bridge is shorted.	Refer to the Magnetics/Power Structure section for further details on correcting armature bridge failures.
CP-106	SCR #6F or #3R Shorted (Soft)	This fault is a result of a malfunction detected during the SCR test. It indicates that either the #6 SCR of the forward armature bridge or the #3 SCR of the reverse bridge is shorted.	Refer to the Magnetics/Power Structure section for further details on correcting armature bridge failures.
CP-107	SCR #1F Did Not Conduct (Soft)	This fault is a result of a malfunction detected during the SCR test. It indicates that #1F SCR of the forward armature bridge did not conduct current and is indicated as an open circuit. A mismatch between drive and motor current horsepower ratings can also cause this malfunction.	Refer to the Magnetics/Power Structure section for further details on correcting armature bridge failures. Check for possible drive/motor mismatch. Check the nameplate of both the motor and drive.
CP-108	SCR #2F Did Not Conduct (Soft)	This fault is a result of a malfunction detected during the SCR test. It indicates that #2F SCR of the forward armature bridge did not conduct current and is indicated as an open circuit. A mismatch between drive and motor current horsepower ratings can also cause this malfunction.	Refer to the Magnetics/Power Structure section for further details on correcting armature bridge malfunctions. Check for possible drive/motor mismatch. Check the nameplate of both the motor and drive.
CP-109	SCR #3F Did Not Conduct (Soft)	This fault is a result of a malfunction detected during the SCR test. It indicates that #3F SCR of the forward armature bridge did not conduct current and is indicated as an open circuit. A mismatch between drive and motor current horsepower ratings can also cause this malfunction.	Refer to the Magnetics/Power Structure section for further details on correcting armature bridge malfunctions. Check for possible drive/motor mismatch. Check the nameplate of both the motor and drive.

Current Processor Faults			
No.	Name	Description	Recovery
CP-110	SCR #4F Did Not Conduct (Soft)	This fault is a result of a malfunction detected during the SCR test. It indicates that #4F SCR of the forward armature bridge did not conduct current and is indicated as an open circuit. A mismatch between drive and motor current horsepower ratings can also cause this malfunction.	Refer to the Magnetism/Power Structure section for further details on correcting armature bridge malfunctions. Check for possible drive/motor mismatch. Check the nameplate of both the motor and drive.
CP-111	SCR #5F Did Not Conduct (Soft)	This fault is a result of a malfunction detected during the SCR test. It indicates that #5F SCR of the forward armature bridge did not conduct current and is indicated as an open circuit. A mismatch between drive and motor current horsepower ratings can also cause this malfunction.	Refer to the Magnetism/Power Structure section for further details on correcting armature bridge malfunctions. Check for possible drive/motor mismatch. Check the nameplate of both the motor and drive.
CP-112	SCR #6F Did Not Conduct (Soft)	This fault is a result of a malfunction detected during the SCR test. It indicates that #6F SCR of the forward armature bridge did not conduct current and is indicated as an open circuit. A mismatch between drive and motor current horsepower ratings can also cause this malfunction.	Refer to the Magnetism/Power Structure section for further details on correcting armature bridge malfunctions. Check for possible drive/motor mismatch. Check the nameplate of both the motor and drive.
CP-113	SCR #1R Did Not Conduct (Soft)	This fault is a result of a malfunction detected during the SCR test. It indicates that #1R SCR of the reverse armature bridge did not conduct current and is indicated as an open circuit. A mismatch between drive and motor current horsepower ratings can also cause this malfunction.	Refer to the Magnetism/Power Structure section for further details on correcting armature bridge malfunctions. Check for possible drive/motor mismatch. Check the nameplate of both the motor and drive.
CP-114	SCR #2R Did Not Conduct (Soft)	This fault is a result of a malfunction detected during the SCR test. It indicates that #2R SCR of the reverse armature bridge did not conduct current and is indicated as an open circuit. A mismatch between drive and motor current horsepower ratings can also cause this malfunction.	Refer to the Magnetism/Power Structure section for further details on correcting armature bridge malfunctions. Check for possible drive/motor mismatch. Check the nameplate of both the motor and drive.
CP-115	SCR #3R Did Not Conduct (Soft)	This fault is a result of a malfunction detected during the SCR test. It indicates that #3R SCR of the reverse armature bridge did not conduct current and is indicated as an open circuit. A mismatch between drive and motor current horsepower ratings can also cause this malfunction.	Refer to the Magnetism/Power Structure section for further details on correcting armature bridge malfunctions. Check for possible drive/motor mismatch. Check the nameplate of both the motor and drive.
CP-116	SCR #4R Did Not Conduct (Soft)	This fault is a result of a malfunction detected during the SCR test. It indicates that #4R SCR of the reverse armature bridge did not conduct current and is indicated as an open circuit. A mismatch between drive and motor current horsepower ratings can also cause this malfunction.	Refer to the Magnetism/Power Structure section for further details on correcting armature bridge malfunctions. Check for possible drive/motor mismatch. Check the nameplate of both the motor and drive.
CP-117	SCR #5R Did Not Conduct (Soft)	This fault is a result of a malfunction detected during the SCR test. It indicates that #5R SCR of the reverse armature bridge did not conduct current and is indicated as an open circuit. A mismatch between drive and motor current horsepower ratings can also cause this malfunction.	Refer to the Magnetism/Power Structure section for further details on correcting armature bridge malfunctions. Check for possible drive/motor mismatch. Check the nameplate of both the motor and drive.
CP-118	SCR #6R Did Not Conduct (Soft)	This fault is a result of a malfunction detected during the SCR test. It indicates that #6R SCR of the reverse armature bridge did not conduct current and is indicated as an open circuit. A mismatch between drive and motor current horsepower ratings can also cause this malfunction.	Refer to the Magnetism/Power Structure section for further details on correcting armature bridge malfunctions. Check for possible drive/motor mismatch. Check the nameplate of both the motor and drive.

Current Processor Faults			
No.	Name	Description	Recovery
CP-119	Fwd SCRs Did Not Conduct (Soft)	This fault is a result of a malfunction detected during the SCR test. It indicates that all SCRs of the forward armature bridge did not conduct current. A mismatch between drive and motor current horsepower ratings can also cause this malfunction.	Refer to the Magnetics/Power Structure section for further details on correcting armature bridge malfunctions. Check for possible drive/motor mismatch. Check the nameplate of both the motor and drive.
CP-120	Rev SCRs Did Not Conduct (Soft)	This fault is a result of a malfunction detected during the SCR test. It indicates that all SCRs of the reverse armature bridge did not conduct current. A mismatch between drive and motor current horsepower ratings can also cause this malfunction.	Refer to the Magnetics/Power Structure section for further details on correcting armature bridge malfunctions. Check for possible drive/motor mismatch. Check the nameplate of both the motor and drive.
CP-121	Open Armature Circuit (Soft)	This fault is a result of a malfunction detected during the SCR test. It indicates that conduction of current in either bridge could not be detected. It is most likely due to the motor and associated wiring being an open circuit.	Refer to the Magnetics/Power Structure section for further details on correcting armature bridge malfunctions. Check that armature leads are not connected to "DB" Pole if a DB Contactor is used. This may also occur if Drive is too large for the motor.

Final Fault Recovery

In general the recovery procedures given for each fault will indicate the actions necessary to correct the fault condition. In some cases more extensive troubleshooting techniques are required to identify the cause of the malfunction. Every effort should be made to determine the cause of the malfunction before replacing components or circuit boards. The malfunction, if left uncorrected, could damage the replacement component.

If the cause of the malfunction cannot be determined execute a SYSTEM RESET to allow the drive to execute its power-on diagnostic routines. These tests may be able to identify the problem present so it can be corrected. If this attempt to clear or identify the problem is unsuccessful, cycle power on the entire drive system. If this still does not give some insight to the problem then review the Malfunctions Not Indicated by a Fault section for additional descriptions of possible fault conditions.

Try to identify any external devices that may effect the operation of the drive. This may include PLC controllers, external relay logic, motion detectors, line monitors, other drives, etc. Assure that these devices are verified as fully operational and correctly applied prior to board replacement.

If everything else in the system appears to be functioning properly, board replacement may be necessary. Follow all ESD protective procedures to guard against damage from ESD. It is important that when changing the boards all firmware modules be replaced with the same part number that was previously installed. It is also very important that all data that was stored in any EEPROM devices be restored in the new board by reprogramming or moving EPROM chips to the new board. When a board is replaced it is suggested that the Start-up Procedure for the drive be repeated to assure correct setup and operation.

Malfuncions Not Indicated by a Fault

General

Some drive malfunctions or operating difficulties do not induce drive fault responses. In some cases the drive is simply not doing what the user desires and a general guide to help determine what is required for the desired response is given here. Each section below will deal with either the function block that is causing the malfunction or in some cases the board related circuits that may effect the desired response.

Logic Control Malfunctions

The Logic control function block is used to command the drive to perform various operations. These include Start, Stop, Jog, etc. The “Logic Command” parameters 150, 151, and 152 are the configuration sink parameters where the commands are specified. The logic bit assignments for all logic commands are identical. Each of these logic command parameters has an assigned order of priority.

Parameter 152 has the highest priority. If Command Enable (Bit 8) is set all other logic command parameters are overridden. An exception is the STOP request (Bit 11) which is always active in every logic parameter at all times. Parameter 152 is the logic command linked to the Bulletin 1300 Programming Terminal and is used when the programming terminal has LOCAL Control.

Parameter 150 is the second highest priority. If bit 8 in parameter 152 is clear and bit 8 is set in parameter 150, then parameter 150 issues the logic commands. If bit 8 of parameters 152 and 150 are clear then control reverts to the lowest priority logic command, parameter 151, regardless of the status of bit 8 in parameter 151. Parameter 150 and 151 can be linked to any adapter’s source configuration parameters. It is important to understand which logic command has control to achieve proper operation.

The 1395 maintains status bits in parameter 100 “Logic Status” which indicates which logic command is presently active. Bits 2 and 3 are used to report which of the logic commands are active. [Table 3.A](#) lists the bit definitions:

Table 3.A Parameter 100 Bit Status Definitions

Bit 3	Bit 2	Definition
0	1	Parameter 150 “Logic Command 1” Active
1	0	Parameter 151 “Logic Command 2” Active
1	1	Parameter 152 “Logic Command 3” Active

A list of logic control malfunctions, symptoms, and possible causes and solutions is provided in the following table.

Logic Control Malfunctions		
Malfunction	Symptom	Solution
Drive Will Not Start.	External Start Command issued, corresponding bit in Logic Command does not change states.	<ul style="list-style-type: none"> External wiring to the adapter or the PLC program is setting the wrong bit. Look for other bits toggling in the Logic Command when initiating the START command. The Discrete adapters digital inputs are programmable to any of the 16 bit positions. Verify that the inputs are properly linked to the desired bits of the logic command. An incorrect configuration link may exist. Check the source parameter from the adapter in the drive to determine if the correct bit is being set. If it is, check that the source parameter is linked to the proper sink parameter.
	External Start Command issued, proper bit is set in Logic Command.	<ul style="list-style-type: none"> Check the READY status bit in parameter 100 "Logic Status" is set to 1. The drive will not start if the ready bit is set to 0. Any of the following conditions will cause the READY bit to be set to 0: A fault, ECOAST string open, any stop bit in any of the three logic commands is set or Armature Voltage is greater than 10% of rated. If no ready bit and Stop bit are set in Param 150 only, check Param 620. It must be set to zero if TB3-3 is not used. ECOAST string is open preventing the drive from starting. Check ECOAST status parameter 101 Bit 1 when VP faults are selected (parameter 630 = 1). Close ECOAST string prior to issuing the START command. A STOP bit is set in one of the three Logic Commands. Check parameters 150, 151, and 152 bit 11 for a set condition. If the bit is set, determine the cause, as the drive will not allow a START if any STOP bit is set. The Bulletin 1300 Programming Terminal has LOCAL control. Check parameter 152 bit 8. If set, the Programming terminal has control, release LOCAL control at the terminal. The wrong Logic Command is selected. If bit 8 in parameter 152 is clear and bit 8 is set in parameter 150, then parameter 150 issues the logic commands. If bit 8 of parameters 152 and 150 are clear then control reverts to the lowest priority logic command, parameter 151, regardless of the status of bit 8 in parameter 151. The drive is executing a CLEAR FAULT. If bit 14 in Logic Command is set, the drive will execute a Clear Fault until the bit is cleared. A start command will not be acknowledged when a CLEAR FAULT is active. Contacting wiring is incorrect. If external circuitry is not required, verify that a jumper is present between TB2-8 & 9 (Series A) or TB2-6 & 7 (Series B 3.6-110A). Parameter 622 Contactor Type may also be set incorrectly, 1 = DC, 0 = AC.
	Drive starts but stops immediately.	<ul style="list-style-type: none"> An incorrect START type is selected in parameter 624 "Maintained Start". If parameter 624 = 1 the start command must be maintained. If the START is removed, the drive will initiate a "Controlled Stop". If parameter 624 = 0, the Start command will be treated as a momentary type input (rising edge triggered) and a STOP command is required to stop the drive.

Logic Control Malfunctions		
Malfunction	Symptom	Solution
Drive Stops even though No STOP Command was Issued.	STOP (bit 11) is set in one of the logic commands.	<ul style="list-style-type: none"> • A safety system external to the drive is issuing a STOP command. This could be coming through any of the Adapters. • The STOP key on the Bulletin 1300 Programming Terminal was pressed which will stop the drive regardless if LOCAL mode is active.
	No STOP bits were set, drive stopped.	<ul style="list-style-type: none"> • ECOAST string was opened during operation. ECOAST string must be closed prior to attempting to restart the drive. • A drive fault was detected and stopped the drive. Examine the Fault Queue to determine the exact cause.
Contactors Remains Closed After A STOP Command.	No STOP bits were set, drive stopped.	<ul style="list-style-type: none"> • The Close Contactor (bit 13) is set in the logic command. Determine what is activating this bit and correct.

Link/Configuration Parameter Malfunctions

The configuration parameters determine where and how the real-time Input and Output signals will be used by the 1395 drive. These types of problems can usually be avoided if the Start-up Procedure is closely followed and the application is well defined. Often the problem can be tracked to a parameter entry error during programming.

Link/Configuration Parameter Malfunctions

Malfunction	Solution
An error in the configuration of the drive often exhibits itself in sink parameters not reflecting the desired input signals from the source parameters.	<ul style="list-style-type: none"> • The easiest way to troubleshoot this type of problem is to start examining the source parameter closest to the actual input. In the case of a signal coming from one of the adapters, verify that the source parameter data is correct. If it is not, the problem exists between the origin of the signal and the Adapter Board. • If the adapter's source parameter is correct then check the sink parameter that is linked to it. The data should be exactly the same, taking into account any unit conversions that may exist. If the data is not exact, a problem in the configuration links exist. This methodology can be used to track data throughout the 1395 drive. • If the 1395 has experienced a Hard or Soft Fault, the System Processor will not process configuration links that direct data transfer to, or from, a processor that is faulted. The same is true if an attempt to direct data to an adapter board that is not mounted is attempted.

Velocity Control Malfunctions

Velocity control is the function block which controls the direction and velocity of the motor. This function block has many set-up and configuration parameters which can affect the operation and performance of the drive. It deals not only with velocity regulation but with torque regulation and most motor related functions. It is important that the Start-up procedure has been properly performed before attempting these troubleshooting techniques.

The following table lists malfunctions, symptoms and possible solutions.

Velocity Control Malfunctions																																					
Malfunction	Symptom	Solution																																			
The motor is rotating at the wrong velocity.	The motor velocity is incorrect, but remains constant during varying loads.	<ul style="list-style-type: none"> The velocity reference selected is incorrect. The initial velocity reference to the drive is selected in the Logic Command word. Bits 0-2 select the reference to be used. Control of the reference selection is made in the active Logic Command word. Logic Command Velocity Reference Selection is shown in the table below. <table border="1" data-bbox="852 499 1414 730"> <thead> <tr> <th>Bit 2</th> <th>Bit 1</th> <th>Bit 0</th> <th>Definition</th> <th>Associated Parameter</th> </tr> </thead> <tbody> <tr> <td>0</td> <td>0</td> <td>0</td> <td>External Velocity Reference</td> <td>154</td> </tr> <tr> <td>0</td> <td>0</td> <td>1</td> <td>Preset Speed 1</td> <td>633</td> </tr> <tr> <td>0</td> <td>1</td> <td>0</td> <td>Preset Speed 2</td> <td>634</td> </tr> <tr> <td>0</td> <td>1</td> <td>1</td> <td>Preset Speed 3</td> <td>635</td> </tr> <tr> <td>1</td> <td>0</td> <td>0</td> <td>Preset Speed 4</td> <td>636</td> </tr> <tr> <td>1</td> <td>0</td> <td>1</td> <td>Preset Speed 5</td> <td>637</td> </tr> </tbody> </table> The External Velocity Reference is correctly selected, but the value reflected in the configuration parameter 154 "Vel Ref Whole" is incorrect. The user supplied reference from one of the adapter boards must be correctly linked to parameter 154. Verify that the configuration links are correctly entered. If parameter 154 is linked to an analog input parameter on the Discrete Adapter, verify that the scaling and offset parameters are properly calibrated for that analog input channel. Also verify that the analog signal being input to the board is correct. For more information refer to the Discrete Adapter Malfunctions section of this chapter. If the Preset speed value is correct, verify that the velocity limits are not clamping the reference. Parameter 608 "Fwd Speed Lim" determines the forward velocity reference clamp and parameter 607 "Rev Speed Lim" determines the reverse velocity clamp. The velocity reference, parameter 102, will be clamped at these limits even if the preset or external velocity reference is higher. If parameter 106 "Velocity Fdbk" does not reflect the actual motor velocity as measured by a hand tach or other independent measuring device. The scaling of the velocity feedback is incorrect. Verify that parameter 621 "Fdbk Device Type" reflects the proper velocity feedback device being used. 0 = Encoder Feedback Selected 1 = Armature Voltage Feedback Selected 2 = Analog Tachometer Selected 3 = No Feedback Device Selected If Encoder Feedback is selected, verify that parameter 609 correctly reflects the pulses/rev rating of the device being used. 	Bit 2	Bit 1	Bit 0	Definition	Associated Parameter	0	0	0	External Velocity Reference	154	0	0	1	Preset Speed 1	633	0	1	0	Preset Speed 2	634	0	1	1	Preset Speed 3	635	1	0	0	Preset Speed 4	636	1	0	1	Preset Speed 5	637
Bit 2	Bit 1	Bit 0	Definition	Associated Parameter																																	
0	0	0	External Velocity Reference	154																																	
0	0	1	Preset Speed 1	633																																	
0	1	0	Preset Speed 2	634																																	
0	1	1	Preset Speed 3	635																																	
1	0	0	Preset Speed 4	636																																	
1	0	1	Preset Speed 5	637																																	

Velocity Control Malfunctions		
Malfunction	Symptom	Solution
The motor is rotating at the wrong velocity. (continued)	The motor velocity is incorrect, but remains constant during varying loads. (continued)	<ul style="list-style-type: none"> • If Armature Voltage Feedback is selected verify that parameter 610 "Rated Motor Volt" and parameter 606 "Base Motor Speed" are correctly entered according to the motor nameplate data. Also verify that parameter 739 "K Arm Volts" is properly scaled to the drive voltage rating. Verify that the field is functioning properly by checking that parameter 612 "Rated Fld Mtr Cur" reflects the rated field current on the motor nameplate. Enter the fields bridge rating as determined by the jumper setting on the Feedback board and the drive nameplate rating, in parameter 616 "Rated Fld Brdg I". The field bridge jumper should select the current rating that is just above the motor field rating. • If an analog tachometer is used, verify that the offset and scaling parameters associated with the adapter's analog input channel are correctly set-up.
	The motor velocity decreases when the load on the motor increases. Torque varies proportional to the load.	<ul style="list-style-type: none"> • The Droop function is incorrectly activated or set-up. Droop allows the velocity to decrease as a function of load torque. As the load on the motor increases the final velocity reference will decrease based on the values of the set-up parameters for the droop function. If parameter 103 is equal to the desired velocity reference but parameter 104 "Final Vel Ref" is not, then the Droop control is affecting the reference. Parameter 657 "Droop Percent" sets the reduction in velocity, in percentage of base speed, that will occur at rated load. Parameter 658 "Droop Filter" determines the gain of a low pass filter which effects the response of the reduction in velocity due to an increase in load.
	The motor velocity decreases due to insufficient motor torque being commanded for the load present. Torque command remains constant or decreases.	<ul style="list-style-type: none"> • The torque taper control may be limiting the torque command. Torque taper is used to reduce the current limit as a function of speed. Set-up is accomplished through parameter 665 "Strt Taper Speed" which sets the velocity at which the maximum torque will begin to be limited. Parameter 666 "End Taper Speed" which set the velocity where the maximum torque will be fully limited, and parameter 667 "Min Taper Cur" which sets the maximum torque level at end taper speed. Verify that this function is properly set-up and not interfering with normal operation.
	The motor velocity decreases due to insufficient armature current being output to the motor. The torque command accurately reflects the output from the velocity regulator but the corresponding armature current reference remains constant or decreases.	<ul style="list-style-type: none"> • The armature current reference, parameter 111 "Arm Current Ref" is being limited by the forward or reverse armature current bridge limits. Parameter 663 "Fwd Brdg Cur Lim" specifies the forward bridge limit while parameter 664 "Rev Brdg Cur Lim" specifies the limit for the reverse bridge. Verify that these parameters are properly set-up to allow for normal operation. • The motor or bridge set-up parameters are incorrectly entered. Verify that parameter 611 "Motor FLA" and parameter 615 "Rated Arm Brgd I" are properly entered. These effect the scaling of torque command to armature current reference.

Velocity Control Malfunctions		
Malfunction	Symptom	Solution
Motor accelerates or decelerates incorrectly	Motor accelerates too fast for application.	<ul style="list-style-type: none"> • The ramp control is disabled in the active Logic Command. Bit 5 must be cleared for the ramp control to function. • Parameter 651 "Accel Time" is too small. This parameter specifies the accel rate as the total time to accelerate from 0 to base speed. • Parameter 663 "Fwd Brdg Lim" is set too high. This parameter controls the armature current output during acceleration which directly controls maximum torque available. • If the motor is accelerating under the JOG command verify that the JOG ramp enable is set. The ramp enable for JOG is activated through parameter 626 "Jog Ramp Enable". If parameter 626 is set to 1, the programmed ramp rates will be used. If parameter 626 is set to 0, no ramp will be implemented during JOG commands.
	Motor accelerates too slow for application.	<ul style="list-style-type: none"> • Parameter 651 "Accel Time" is too large. This parameter specifies the accel rate as the total time to accelerate from 0 to base speed. • The ramp control is enabled in the active Logic Command. If no ramp control is desired, bit 5 in the active Logic Command must be set for the ramp control to be by-passed. • Parameter 663 "Fwd Brdg Lim" is set too low. This parameter controls the armature current output during acceleration which directly controls maximum torque available. • The torque taper control may be limiting the torque command. Torque taper is used to reduce the current limit as a function of speed. Its set-up is accomplished through parameter 665 "Strt Taper Speed" which sets the velocity at which the maximum torque will begin to be limited. Parameter 666 "End Taper Speed" which sets the velocity where the maximum torque will be fully limited, and parameter 667 "Min Taper Cur" which sets the maximum torque level at end taper speed.

Velocity Control Malfunctions		
Malfunction	Symptom	Solution
Motor accelerates or decelerates incorrectly (continued)	Motor accelerates too slow for application. (continued)	<ul style="list-style-type: none"> • Insufficient torque may be available due to improper field set-up. The motor field parameters must be properly set up to obtain maximum available torque. Verify that the field control is properly calibrated. • If the motor is accelerating under the JOG command verify that the JOG ramp enable is set. The ramp enable for JOG is activated through parameter 626 "Jog Ramp Enable". If parameter 626 is set to 1, the programmed ramp rates will be used. If parameter 626 is set to 0, no ramp will be implemented during JOG commands.
	Motor decelerates too fast for application.	<ul style="list-style-type: none"> • The ramp control is disabled in the active Logic Command. Bit 5 must be cleared for the ramp control to function. • Parameter 652 "Decel Time" is too small. This parameter specifies the decel rate as the total time to decelerate from base speed to zero. • Parameter 664 "Rev Brdg Lim" is set too high. This parameter controls the armature current output during deceleration which directly controls maximum torque available. • If the motor is decelerating under the JOG command verify that the JOG ramp enable is set. The ramp enable for JOG is activated through parameter 626 "Jog Ramp Enable". If parameter 626 is set to 1, the programmed ramp rates will be used. If parameter 626 is set to 0, no ramp will be implemented during JOG commands.
	Motor decelerates too slow for application.	<ul style="list-style-type: none"> • Parameter 652 "Decel Time" is too large. This parameter specifies the decel rate as the total time to decelerate from base speed to zero. • The ramp control is enabled in the active Logic Command. If no ramp control is desired, bit 5 in the active Logic Command must be set for the ramp control to be by-passed. • Parameter 664 "Rev Brdg Lim" is set too low. This parameter controls the armature current output during deceleration which directly controls maximum torque available. • The torque taper control may be limiting the torque command. Torque taper is used to reduce the current limit as a function of speed. It's set-up is accomplished through parameter 665 "Strt Taper Speed" which sets the velocity at which the maximum torque will begin to be limited. Parameter 666 "End Taper Speed" which set the velocity where the maximum torque will be fully limited, and parameter 667 "Min Taper Cur" which sets the maximum torque level at end taper speed. • Insufficient torque may be available due to improper field set-up. The motor field parameters must be properly set up to obtain maximum available torque. Verify that the field control is properly calibrated. • If the motor is decelerating under the JOG command verify that the JOG ramp enable is set. The ramp enable for JOG is activated through parameter 626 "Jog Ramp Enable". If parameter 626 is set to 1, the programmed ramp rates will be used. If parameter 626 is set to 0, no ramp will be implemented during JOG commands

Velocity Control Malfunctions		
Malfunction	Symptom	Solution
The motor velocity is not controlled and excessive velocity occurs.	The motor velocity is excessive and parameter 106 "Velocity Fdbk" remains constant or near zero.	<ul style="list-style-type: none"> The velocity feedback device is incorrectly selected. Verify that parameter 621 "Fdbk Device Type" reflects the proper velocity feedback device being used. 0 = Encoder Feedback Selected 1 = Armature Voltage Feedback Selected 2 = Analog Tachometer Selected 3 = No Feedback Device Selected If Encoder Feedback is selected and the device has malfunctioned, or no device is connected, or the wrong encoder PPR is entered in Param 609, the motor will accelerate uncontrollably and fault on VP-10 Feedback Loss. If Armature Voltage Feedback is selected, the motor should only runaway if an internal component malfunctions. The armature voltage is sensed at the DC contactor connections. It is then scaled on the Feedback Board and measured on the Main Control Board. If an analog tachometer is selected and the device has malfunctioned or is not connected, the motor will accelerate uncontrollably and fault. Also if the scaling is incorrect, or the analog input signal from the tach is over voltage, the motor will accelerate uncontrollably.
	 <p>ATTENTION: If no Feedback Device is selected, uncontrollable acceleration of the motor could occur. This is a potentially dangerous situation because the drive will not trip on a Feedback Loss fault. Parameter 621 must only be set to (3) when operating the drive as an external torque regulator in follower type applications.</p>	
	The motor accelerates uncontrollably and parameter 106 "Velocity Fdbk" has the wrong polarity for the direction commanded.	<ul style="list-style-type: none"> The field polarity and the direction information from the encoder must match for proper control. Forward direction of the motor is defined as positive armature voltage +A1/-A2 and phase A must lead phase B of the encoder for CCW rotation as viewed from the commutator end of the motor. Forward direction can be defined as CW rotation by switching the polarity of the field connections and by switching one encoder signal pair. The same holds true for an analog tachometer. The polarity of the tach signal must match the polarity of the armature voltage. Forward rotation can be defined as either CW or CCW depending on the polarity of both signals.
	The motor accelerates uncontrollably with the motor turning in the same direction as the velocity command.	<ul style="list-style-type: none"> Switch the encoder signal pairs or the analog tach polarity. Then verify that parameter 107 "Position Feedback" counts up to a higher value as the motor is rotated in the forward direction.
The motor runs away with the motor turning in the opposite direction as the velocity command.	<ul style="list-style-type: none"> Verify that parameter 107 "Position Feedback" counts up to a higher value when the motor is rotated in the forward direction. If it does, reverse the polarity of the field connections. 	
The motor turns at the correct speed, but rotates in the wrong direction.	Parameter 107 counts down to a lower value when the motor is rotated in a forward direction.	<ul style="list-style-type: none"> Reverse both the encoder signal pairs/analog tach polarity and the polarity of the field connections.

Velocity Control Malfunctions		
Malfunction	Symptom	Solution
The motor over/undershoots the target velocity.	Excessive overshoot of the target velocity is evident when the velocity is stepped and overshoots to a speed faster/slower than commanded. The regulator then compensates and velocity swings back the other way, sometimes oscillating several cycles before achieving a constant velocity. When approaching zero speed the velocity may actually pass through zero speed and rotate in the opposite direction until zero speed is achieved.	<ul style="list-style-type: none"> Excessive overshoot usually indicates that the velocity loop is tuned incorrectly. The gains of the velocity loop, the actual values of, and the ratio between, KP and KI are incorrect, or the feed forward term (KF) is too high. Decreasing KI or increasing KP should reduce the amount of overshoot. Tune the velocity loop using Autotune. By decreasing parameter 661 "KF Velocity Loop" the feed forward term will be increased which will reduce overshoots but also decrease the gain of the loop in respect to velocity reference. The response to a load disturbance is unaffected by KF. Refer to the Start-up Procedure for more information. If the problem occurs when approaching zero speed it may help to increase parameter 710 "Zero Speed Tol". This will cause the drive to cease regulation sooner and allow the motor to coast to a smooth stop. Refer to the Start-up Procedure for more information.
	Excessive undershoot of the target velocity is evident when the velocity is stepped and does not reach the target velocity in the desired time.	<ul style="list-style-type: none"> Excessive undershoot usually indicates that the velocity loop is tuned incorrectly. The gains of the velocity are too low or the Feedforward Term (KF) is too low. Increasing parameters 659 "KI Velocity Loop" and 660 "KP Velocity Loop" will increase the gain of the system to allow a faster response to variations in velocity feedback. By increasing parameter 661 "KF Velocity Loop" the feedforward term will be decreased which will reduce undershoots but also increase the gain in respect to the velocity reference. Refer to the Start-up Procedure for more information.

Velocity Feedback Device Malfunction

Velocity Feedback Device malfunctions can be difficult to diagnose and correct. In this section troubleshooting techniques dealing with each type of velocity feedback device will be explained.

Encoder Device Malfunction

The encoder feedback device is mounted on, or near the motor and is mechanically coupled to the motor shaft. It senses motor rotation and outputs a dual channel quadrature output waveform. The 1395 requires that the encoder output be differential line drivers at 5–12V signal levels. Channel A and Channel B are square wave type outputs that are 90 Degrees out of phase. When rotating in the CCW direction, as viewed from the commutator end, Channel A leads Channel B (Waveform 1). Each differential channel has an inverted and non-inverted signal, for example A and /A (Waveform 3).

The encoder requires a power supply. The 1395 provides a +12V isolated supply capable of 500mA of current with a current foldback feature that protects the power supply should the current draw exceed 500mA. If different power supply requirements exist for the chosen feedback device, the supply must be provided external to the 1395 drive. It is important that the Start-up Procedure has been properly performed before attempting these troubleshooting techniques.

Test points on the Main Control Board (TP12 – Encoder Phase B (ENCB) and TP15 – Encoder Phase A (ENCA)) can be used to monitor the frequency and phase relationships of the encoder. An oscilloscope should be used to monitor these signals with respect to AGND (TP57). The waveforms should be logic level signals, 0 to 5V square-waves.



ATTENTION: Extreme care must be used when probing the test points on any board. Improper techniques may result in damage to the circuit and personal injury. Do Not attempt probe tests that are not listed here. Damage to extremely sensitive circuits may cause unpredictable drive operation and unintended motor rotation.

The frequency is proportional to speed and the pulse rate of the encoder, referred to as the “Pulse/Rev” rating on the nameplate. The speed of the motor can be calculated by: $\text{Speed (RPM)} = [\text{Frequency (Hz)} \times 60] / [\text{Pulses/Revolution}]$.

The direction of rotation is determined by the phase relationship of ENCA to ENCB. ENCA and ENCB should always be 90 Degrees out of phase with each other. If ENCA leads ENCB by 90 Degrees then the direction of rotation is defined as forward. If ENCB leads ENCA by 90 Degrees then the direction of rotation is defined as reverse. Waveform 1 shows forward rotation with ENCA as the top waveform. Waveform 2 is reverse rotation with ENCA as the top waveform.

The following table lists malfunctions, symptoms, and possible solutions.

Encoder Device Malfunction		
Malfunction	Symptom	Solution
The drive faults on "VP-10 Feedback Loss". This indicates that the measured velocity from the encoder is less than the level programmed in parameter 732 "Tach Loss Vel" and the velocity calculated from the CEMF of the motor is greater than the level programmed in parameter 731 "Tach Loss CEMF".	The velocity feedback is not being registered because jumpers on the Main Control Board are selected incorrectly for the encoder in use. Verify that the jumper selection for the encoder output voltage on the Main Control Board is correct.	<ul style="list-style-type: none"> For 5V differential encoders J8, J9, and J10 should be in position 1-2. For 12V differential encoders J8-J10 should be in position 2-3.
	The encoder feedback device is inoperative due to lack of encoder power supply. Measure the encoder power supply from the 1395 drive by measuring from TB3-13 (+) to TB3-14 (-) with a DVM. The voltage level should be +12V, 10%.	<ul style="list-style-type: none"> If the supply is near zero remove all power to the drive. Disconnect the encoder supply connections at TB3-13 and TB3-14. Apply power and repeat the measurement. If the supply is restored to its proper level the encoder power supply foldback circuit was activated. Remove all power to the drive and connect the supply connections to the encoder. If upon applying power, the supply again folds back, excessive current draw is occurring. This could be due to shorted supply connections or a damaged encoder. Check all wiring between the 1395 terminal strip and the encoder. If the wiring is functional, replace the encoder. If the supply remains low even after the encoder is disconnected, replace the Main Control Board.
	The encoder output signals are lost due to a malfunction of the line drivers in the encoder device.	<ul style="list-style-type: none"> Measure the encoder output signals at the 1395 terminal strip. Place a scope probe at TB3-17 and at TB3-18 and reference them to TE. These signals represent the differential channel outputs for phase B. TB3-17 is inverted and TB3-18 is non-inverted. Rotate the shaft of the motor, either by mechanical means or under armature voltage feedback control. The resulting waveform should be similar to Waveform 3. If the proper signal is not observed, replace the encoder. Note: If using armature voltage feedback to troubleshoot the encoder, the set-up procedure for armature voltage feedback must be performed first for proper operation. Use the same method to check phase A of the encoder output. Place a scope probe at TB3-19 and TB3-20 and reference them to TE. TB3-19 is inverted and TB3-20 is non-inverted. Rotate the shaft of the motor, either by mechanical means or under armature voltage feedback control. The resulting waveform should be similar to Waveform 3. If the proper signal is not observed, replace the encoder.
	The encoder output signals are present at TB3, but the quadrature relationship is incorrect between phases A and B.	<ul style="list-style-type: none"> Open the drive door and lower the Main Control Board assembly. Locate test points TP12 and TP15 on the left side of the board near U13. TP12 is the phase B signal and TP15 is the phase A. Verify that proper quadrature exists between A and B. Rotate the motor in the CCW direction, as viewed from the commutator. The resulting waveform should be similar to Waveform 1 shown in Figure 3-1. If the encoder signals are in phase or 180 Deg out of phase, check the wiring to ensure that the signal lines are not shorted. If the wiring is functional replace the encoder.
Encoder output signals present at TB3, not present on Main Control Board. Encoder interface failure.	<ul style="list-style-type: none"> Replace the Main Control board. 	

Figure 3.1 Waveform 1 - Encoder Phases A (TP15) and B (TP12), Forward (CCW)

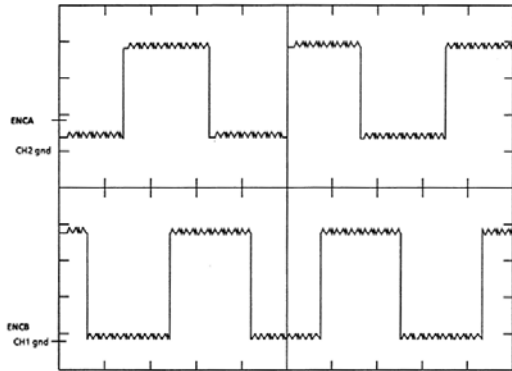

Figure 3.2 Waveform 2 - Encoder Phases A (TP15) and B (TP12), Reverse (CW)

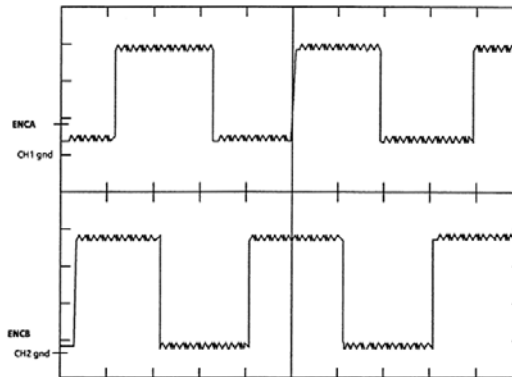

Figure 3.3 Waveform 3 - Encoder Signals A (TB3-20) and A NOT (TB3-19)

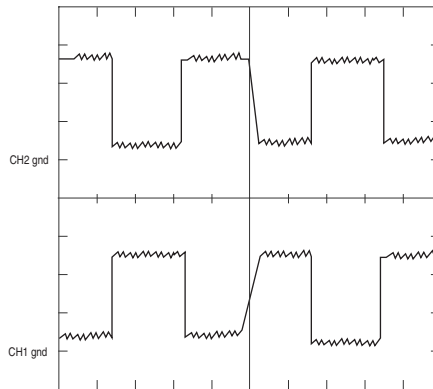
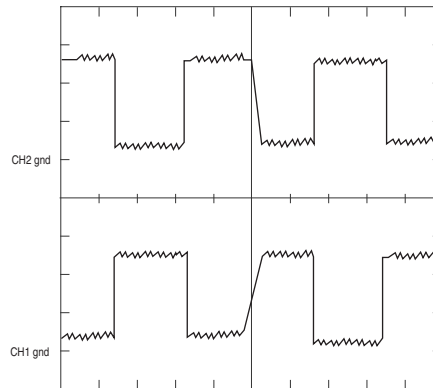

Figure 3.4 Waveform 4 - Encoder Signals B (TB3-18) and B NOT (TB3-17)



Analog Tachometer Malfunction

The analog tachometer device generates a DC voltage that is direction sensitive and proportional to speed. The tach output must be connected to an analog input channel on the Discrete Adapter Board. Most industrial tachs have an output greater than the +/-10V range of the analog inputs. The tach output must be scaled down, by an external voltage divider network.



ATTENTION: Connecting a Tach which has an output range greater than +/-10V directly to the analog input channel can severely damage the adapter card.

The tach signal then must be scaled in the adapter card to determine the proper relationship of output voltage/motor velocity to Base Speed in Drive Units. This scaled configuration data must then be linked to Parameter 156 “Tach Velocity”

Many problems relate to the scaling of the tach signals. Below is a procedure for checking the scaling of the analog tach feedback for proper drive operation.

1. Determine the Volts/RPM rating of the tach. It is usually on the tach nameplate. Multiply this rating times the absolute maximum speed the motor will be commanded to accelerate to. (This value should also be programmed in Parameter 607 “Rev Speed Lim” and 608 “Fwd Speed Lim” to ensure the velocity command will be properly clamped).
2. This Max Volts output must be scaled to a level within the +/- 10V analog input channel range. This can be accomplished by using a voltage divider that will take the Max Volts output and scale it to a maximum 9V input. This allows for protection against 10% overshoot.

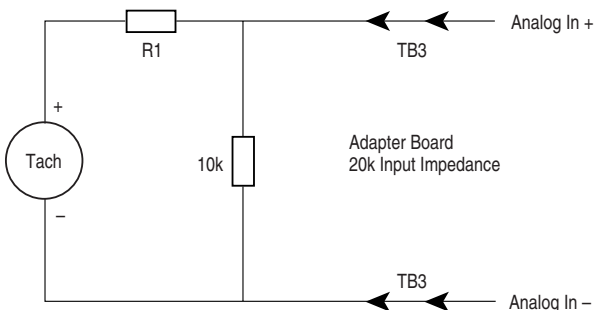

This circuit uses a 10k resistor across the input channel and R1 represents the dropping resistor for the scaling network. To determine the value of R1 use the following equation:

$$\frac{(\text{Max Volts Output}) \times 6666}{9V} - 6666 = R1$$

3. The analog input channel on the adapter board must now be scaled to represent an accurate velocity feedback signal. First determine the analog input signal for base speed. Parameter numbers are given in () where applicable

$$\frac{\text{Base Motor Speed (606)} \times 9V}{\text{Max Speed}} = \text{Base Speed Input}$$

- This input voltage at base speed is then converted to raw Adapter units according to the equation given here.

$$\frac{\text{Base Speed Input} \times 2048}{10} = \text{Raw Adapter Units}$$

- The Raw Adapter units are then used to determine the correct scaling parameter value according to the equation shown here

$$\frac{4096}{\text{Raw Adapter Units}} = \text{Scaling Parameter Value}$$

- The scaling parameter value should then be entered into the associated analog input scaling set-up parameter. This procedure should be correct to within 5%. Verify that the scaling is correct by measuring the actual motor velocity with a hand tachometer. Fine tune the scaling by adjusting the appropriate value to minimize any error.
- Any drift at zero speed can be virtually eliminated by adjusting the offset parameter associated with the channel in use.

Below is a list of malfunctions, symptoms, and possible solutions.

Analog Tachometer Malfunctions		
Malfunction	Symptom	Solution
Drive faults on "VP-10 Feedback Loss". This indicates that the measured velocity from the tachometer is less than the level programmed in parameter 732 "Tach Loss Vel" and the velocity calculated from the CEMF of the motor is greater than the level programmed in parameter 731 "Tach Loss CEMF".	The velocity feedback is not being registered in parameter 156. Rotate the shaft of the motor, either by mechanical means or under armature voltage feedback control. Note: If using armature voltage feedback to troubleshoot the tach circuit, the set-up procedure for armature voltage feedback must be performed first for proper operation. If the Adapter configuration parameter indicates proper data, an incorrect configuration link is in the drive.	Verify that the analog input configuration parameter is linked to parameter 154. Also verify that external velocity feedback is selected. Examine parameter 621 "Fdbk Device Sel" to verify its value is 2.
	Adapter configuration parameter indicates no velocity feedback. Tach signal incorrectly connected to 1395.	Verify that the tach signal is present at the TB3 terminals which correspond to the desired analog input channel. If it is not, then check all wiring and connections that exist between the 1395 and the tachometer. If the wiring is functional replace the tachometer. If the signal is present at TB3, verify the scaling and offset parameters associated with the selected analog input channel.
Velocity control is maintained until the velocity exceeds a certain threshold and the motor accelerates uncontrollably.	The velocity feedback is proportional to the velocity of the motor until a certain level is reached and the velocity feedback value is clamped and the motor accelerates uncontrollably.	The tachometer voltage is exceeding the input voltage range of the analog input channel on the adapter board. When the voltage range is exceeded the feedback data will become clamped and the motor will accelerate uncontrollably. It will be necessary to rescale the voltage divider network, external to the drive, to assure that the tach signal will remain inside the operating range of the analog input channel throughout the entire speed range of the motor.
The motor is rotating at the wrong speed.	The velocity feedback viewed in parameter 106 "Velocity Fdbk" does not match the actual velocity of the motor, as measured by independent means (hand tach).	The scaling of the tach signal must be verified. The first scaling takes place at the voltage divider network which reduces the tach output to a level within the 10V input range. The second scaling takes place in the adapter board which converts the incoming signal to Drive Units representing motor velocity.

Armature Current Control

Armature current control is performed in the Current processor. Most of the malfunctions that occur produce fault responses that indicate the problem. In some cases improper tuning will cause nuisance faults and abnormal operation to occur. If the armature control parameters are improperly calibrated, malfunctions will occur and possible damage to the drive may occur. Most malfunctions described here will deal with the symptoms the drive will exhibit when the parameters are misadjusted.

Following is a list of malfunctions, symptoms, and possible solutions.

Armature Current Control Malfunctions		
Malfunction	Symptom	Solution
Armature current output is well below rated or well above the rated level. This results in decreased or increased available torque. The velocity control up to and including the commanded torque has been checked and is functioning properly.	The armature current reference is below the level called for by Torque Command. When Parameter 110 "Torque Command" is 100%, Parameter 111 "Arm Current Ref" should reflect the motor's rated armature current. The torque command should remain proportional to the armature current reference from zero to base speed.	<ul style="list-style-type: none"> The ratio of torque command to armature current reference is wrong. This ratio is calculated based on Parameters 611 "Motor Arm FLA" and 615 "Rated Arm Brdg 1". Parameter 611 should reflect the nameplate full load armature current rating of the motor. Parameter 615 should reflect current rating of the drive as listed on the product label. If either of these parameters is incorrectly entered, the armature current output will be incorrect.
Measured armature current to the motor does not equal the commanded armature current.	The armature current measured by the clamp on ammeter is not equal to the current reflected in parameter 112 "Arm Current Fdbk".	<ul style="list-style-type: none"> Verify parameter 615 reflects the bridge current rating of the drive as listed in the Start-Up chapter of the Installation Manual. If incorrect, the armature current output scaling will be incorrect and the level of the current to the motor will be inaccurate.
 <p>ATTENTION: If a Feedback Board is ever replaced due to a component malfunction, the scaling resistors mounted in TB2 and TB3 will be transferred to the new board prior to installation. If TB2 and TB3 resistors are omitted or improperly installed, the current scaling will be incorrect and damage to the drive may occur.!</p>		
A step in torque command causes the drive to trip on an overcurrent trip.	A step in torque command results in a excessive pulse of armature current, faulting the drive.	<ul style="list-style-type: none"> The current loop may be improperly tuned. If the gains are too high the step command will cause the current regulator to over react and produce too much current. Tune the drive to the proper current loop gain using the Autotune procedure. Reduce the value of Parameter 668 "di/dT Limit". This parameter limits the rate of change allowed for the armature current reference. By reducing this value, the control will increase the armature current reference at a slower rate when given a step torque command. Verify that all six pulses are present in the armature current waveform. To monitor the armature current waveform place a scope probe on test point TP5 on the Main Control Board. Reference the scope to TP57 AGND. If one or more are missing, a malfunction in the power structure has occurred, refer to Magnetics/Power Structure section of this chapter for further details on correcting armature bridge malfunctions. Check the motor commutator for signs of arcing and excessive, or rough, brush wear. Consult a motor rebuild.

Armature Current Control Malfunctions		
Malfunction	Symptom	Solution
Drive faults on an overcurrent fault as soon as the contactor closes.	A step in torque command results in a excessive pulse of armature current, faulting the drive.	<ul style="list-style-type: none"> • Current loop may be improperly tuned. If the gains are too high the initial current command will cause the current regulator to over react and command too much current. Tune the drive to a lower current loop gain using the Autotune procedure. • Motor armature winding may be shorted. Check armature resistance from A1 to A2, A1 to PE, and A2 to PE. If necessary, disconnect the motor armature leads from the 1395 and use a Megger to apply high voltage from A1 to PE and A2 to PE. This will indicate if motor insulation breakdown has occurred. • If the motor is not shorted, a malfunction has occurred in the armature bridge. Refer to Magnetics/Power Structure section for further details on correcting armature bridge failures.

Main Control Board Test Points

The following paragraphs describe test points on the Main Control Board that can be used to diagnose armature bridge malfunctions:



ATTENTION: Extreme care must be used when probing the test points on any board. Improper techniques may result in damage to the circuit and personal injury. Do Not attempt probe tests that are not listed here. Damage to extremely sensitive circuits may cause unpredictable drive operation and unintended motor rotation.

TP2

Armature Current Feedback can be used to monitor the armature current as sensed by the current transformers in the AC lines. These signals are unipolar representations of the armature current. Conduction in either bridge results in a positive waveform in respect to AGND. Either an oscilloscope (preferred) or a DVM can be used to monitor this signal with respect to AGND (TP57). Scaling of the signal is $2V = \text{bridge rated current}$ (drive nameplate rating).

The monitored waveform should have equally spaced pulses at a period of 2.7ms. Waveform 5 represents continuous current conduction. Waveform 6 is discontinuous current conduction.

TP21

Armature Voltage Feedback is sensed at the output side of the DC contactor. It is scaled down to a +/-10V signal and accurately reflects the voltage waveform across the motor armature. The waveform measured at TP21 is inverted in respect to the actual voltage across A1 to A2. Either an oscilloscope (preferred) or a DVM can be used to monitor this signal with respect to AGND (TP57). It is scaled on the low voltage drive (150-300V DC) as $1V \text{ signal} = 65V \text{ armature voltage}$. The high voltage drive (300-500V DC) is scaled as $1V \text{ signal} = 125V \text{ armature voltage}$. The waveforms shown in Figures 3-5 through 3-11 represent the typical signal that occurs during the four quadrants of bridge operation.

Figure 3.5 Waveform 5 - Armature Current Feedback (TP2) - Continuous Current

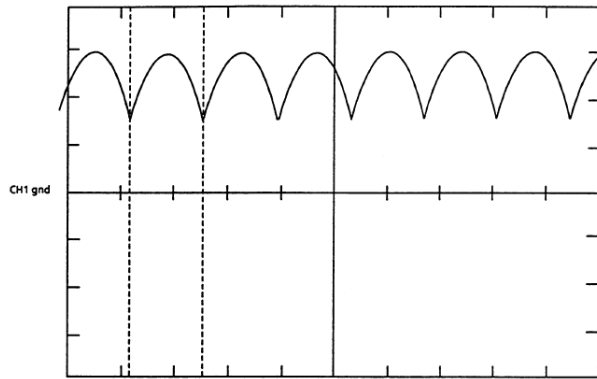

Figure 3.6 Waveform 6 - Armature Current Feedback (TP2) - Discontinuous Current

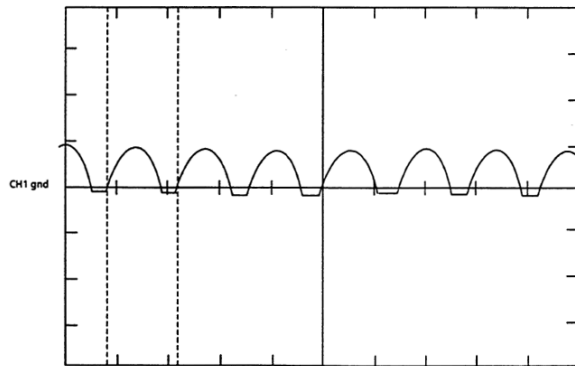

Figure 3.7 Waveform 9 - Armature Voltage Feedback (TP21) - Motoring Forward

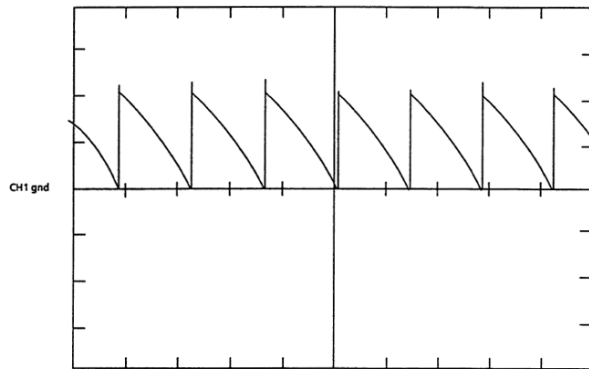

Figure 3.8 Waveform 8 - Armature Voltage Feedback (TP21) - Regen Forward

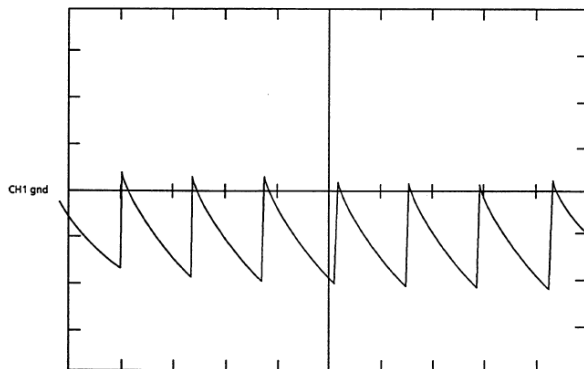

Figure 3.9 Waveform 7 - Armature Voltage Feedback (TP21) - Motoring Reverse

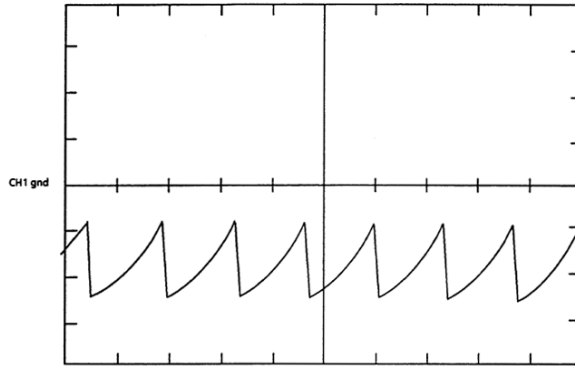

Figure 3.10 Waveform 10 - Armature Voltage Feedback (TP21) - Regen Reverse

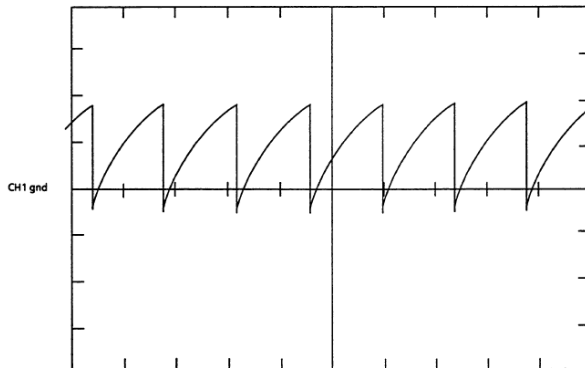
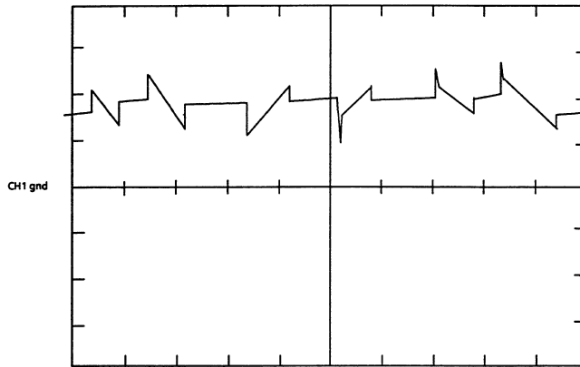

Figure 3.11 Waveform 11 - Armature Voltage Feedback (TP21) - Constant Velocity w/ No Load



Field Current Control

Field current control is performed in both the Velocity Processor and the Current Processor. The Velocity Processor controls the field current reference based on velocity, armature voltage, mode of operation, etc. The Current Processor performs the field current regulation based on the reference it receives from the Velocity Processor and the field current feedback measured by the Current Processor.

Most control related malfunctions are experienced when initially calibrating the field control for operation below Base Speed. The field must be calibrated for operation in both constant Torque mode and constant Horsepower mode. Constant Torque mode occurs below base speed when the motor has full field current applied and maximum rated torque can be achieved. Constant Horsepower mode occurs above base speed. The field control reduces the field current reference to maintain a constant armature voltage as velocity increases. The torque output decreases with an increase in velocity to maintain a constant horsepower output. This functionality is commonly referred to as “Field Weakening”.

The following is a list of malfunctions, symptoms, and possible solutions for the field control.

Field Current Control Malfunctions		
Malfunction	Symptom	Solution
The exterior surface of the motor reaches a high temperature when the motor is stopped.	The motor case temperature is excessive while the drive is in a stand-by mode. The drive is powered on, but not enabled.	<ul style="list-style-type: none"> The Field Economy function in the drive is not enabled. The Field Economy function reduces the field reference when the motor is stopped to reduce the power in the motor. Bit 0 of parameter 627 “Flux Mode Select” should be set to 1 to enable the Field Economy function. The field flux reference will be reduced to the level specified in parameter 674 “Fld Economy Ref” after the motor has been stopped for a period of time exceeding the value specified in parameter 675 “Fld Economy Dly”. A typical value of field economy is 30-50%. Setting the field economy too low may cause a drive fault to occur upon starting the drive. This would happen when the field bridge goes into discontinuous conduction when in field economy mode. If this occurs, it will take too long for the field current to increase to the commanded level once a START command is issued and the drive will fault on VP-13 “Motor Field Loss” or VP-36 “Excess Arm Voltage”. The field economy reference should be set so the field bridge is in continuous conduction.
The field current and resulting CEMF vary above base speed with a constant speed reference.	With a constant speed reference above base speed, the velocity and field current vary.	<ul style="list-style-type: none"> The CEMF regulator is unstable, causing the field current reference to oscillate. The gains of the regulator are determined by parameter 672 “KI Flux” and parameter 673 “KP Flux”. Decrease parameter 672 until stable operation is achieved.

Field Current Control Malfunctions		
Malfunction	Symptom	Solution
Measured field current is not equal to parameter 118 "Fld Cur Fdbk".	If the field current measured by the clamp-on ammeter is significantly different (greater than 10%) from the value reported in parameter 118 the field feedback scaling is incorrect.	<ul style="list-style-type: none"> Initial calibration of the field control determines the field current below Base Speed. The nameplate rating of both the motor and drive determine the initial scaling calibration. Enter the motor nameplate current rating in parameter 612 "Rated Fld Mtr Cur". Enter the field's bridge rating as determined by the field current jumper J1, not the drive nameplate rating, in parameter 616 "Rated Fld Brdg I". Refer to the Start-Up chapter of the 1395 Installation Manual for values for parameters 612 and 616. If the initial calibration is correct, the Feedback Board may have experienced a failure. This would be typified by the field being phased full on and full current flowing in the motor field circuit. However, no field current feedback would be registered at parameter 118 "Fld Current Fdbk". Replace the Feedback Board, being sure that the burden resistors installed at TB2 and TB3 are of the same value and type as installed in the original board.
The field current reference is not equal to the motor nameplate rating during velocity regulation below base speed.	Parameter 117 "Fld Current Ref" is not equal to parameter 612 "Rate Fld Motor Cur". For operation below base speed, these two values should be equal.	<ul style="list-style-type: none"> Verify that parameter 676 "Field Flux Ref" is equal to 100%. If it is less than 100% a reduced field current reference will be commanded. Also verify that parameter 115 "Flux Command" is equal to 100%, when parameter 676 is equal to 100%. If it is not, the flux reference select may be improperly programmed. For applications where the velocity processor generates it's own field current reference, bit 2 of parameter 627 "Flux Mode Select" should be set to 0. If bit 2 is set to 1, parameter 159 "Flux Feed Forward" will be used as the field flux reference. Parameter 159 is used when an external field flux reference is brought into the drive, typically under master/follower configurations. Typically in a follower drive (torque regulator) application, the field flux reference will be brought into the follower, from the master drive (velocity regulator). If the unit experiencing the malfunction is a stand alone or master velocity regulator, it will generate a field current reference internally.
The field current feedback is not equal to the field current reference indicating that proper regulation cannot be obtained.	Parameter 117 "Fld Current Ref" is not equal to parameter 118 "Fld Current Fdbk".	<ul style="list-style-type: none"> Verify the field voltage rating of the motor and the field voltage rating of the drive under use is compatible. A drive with a 230V AC input rating is capable of a field output of 150V DC, a 380V AC of 250V DC, a 415V AC of 270V DC, and a 460V AC of 300V DC.
The measured motor voltage at base speed, no load, is not equal to the rated nameplate motor armature voltage.	The armature voltage measured with a DVM at A1 and A2 of the DC contactor, at base speed with no load applied, is not equal to the value entered at parameter 610 "Rated Motor Volt".	<ul style="list-style-type: none"> Fine tune the calibration of the constant field control to match the flux requirements of the motor. The nameplate rating of field current is a general estimate published by the motor manufacturer, if more exact calibration is required perform the following adjustments: Operate the motor at Base Speed velocity, under no load, and place a DVM across the DC contactor at A1 and A2. Verify that parameter 676 "Field Flux Ref" is equal to 100%. Adjust parameter 612 "Rate Fld Mtr Cur" in small increments until the voltage measured at A1 and A2 is equal to the rated armature motor voltage as stated on the motor nameplate. (Increasing parameter 612 will cause the armature voltage to increase). If parameter 612 must be increased to a value greater than parameter 616, the next higher J1 setting on the feedback board must be selected and the value of parameter 616 must be changed to reflect the higher setting. Remove all power to the drive before changing the J1 jumper selection. Verify that the motor rated field is compatible with the drive rating in both voltage and current.

Field Current Control Malfunctions		
Malfunction	Symptom	Solution
The measured motor voltage above base speed does not remain constant.	When the actual motor velocity exceeds the base speed of the motor, the armature voltage continues to vary proportional to velocity.	Verify that the field weakening enable, bit 1 of parameter 627 "Flux Mode Select" is set to 1. This bit must be set if constant horsepower operation is desired.
	When the actual motor velocity exceeds the base speed of the motor, the armature voltage varies, but not directly proportional to velocity. The load on the motor is relatively constant.	<ul style="list-style-type: none"> Verify that the Field Flux Tune has been executed under Autotune control. This must be performed prior to operating the drive above base speed to ensure that the field control parameters have been set to reflect the flux characteristics of the motor. Autotune will calibrate the field weakening parameters 677 to 685 and enter them into the parameter table. <p>In addition, the CEMF regulator must also be tuned. The CEMF regulator varies the field reference based on the CEMF of the motor being measured. The CEMF regulator will adjust the field reference during operation to maintain a constant Armature voltage. The response of this regulator is controlled by parameter 672 "KI Flux" and parameter 673 "KP Flux". These parameters control the gain of the CEMF regulator. Setting parameter 687 "CEMF Preload" to zero and parameter 627 "Flux Mode Select" bit 5 (CEMF Set) to 1 will disable the CEMF regulator. If bits 4 (Hold) and 5 (Set) in parameter 627 are both set to 0, the CEMF regulator is automatically enabled and uses parameter 610 "Rated Motor Volt" as the reference.</p> <ul style="list-style-type: none"> Verify that the external CEMF regulator control, bit 3 of parameter 627 "Flux Mode Select" is set to 0. If this bit is set to 1, parameter 160 "CEMF Ref" will be used to determine the CEMF regulator reference, instead of the rated motor voltage parameter. Also verify that bits 4 and 5 are set to zero under normal operation. If bit 4 is set to 1 the CEMF regulator will hold its output to the last value before the bit was set. If bit 5 is set to 1 the output of the CEMF regulator will be reset to the value specified in parameter 687 "CEMF Reg Preload". <p>Parameter 686 "Fld Weaken Speed" determines the velocity at which the field weakening function will become active.</p>
The measured motor voltage above base speed does not remain constant. (continued)	When the actual motor velocity exceeds the base speed of the motor, the armature voltage varies directly with the load on the motor.	<ul style="list-style-type: none"> If the armature voltage changes significantly (greater than 5%) with an increasing load, the armature resistance compensation is too high. Reduce parameter 614 "Arm Resistance". If armature voltage increases significantly with an increasing load, parameter 614 is too low. A typical range is 3 to 10%. <p>TP25-Field Current Feedback can be used to monitor the field current as sensed by the current transformer FCT. This signal is scaled so that 3VDC = full rating of the bridge as determined by the jumper setting of J1 on the feedback board or the PSI/Switcher based on the HP rating. Either an oscilloscope (preferred) or a DVM can be used to monitor this signal with respect to AGND (TP57). The waveform in Figure 3-12 shows the typical waveform of field current feedback.</p>

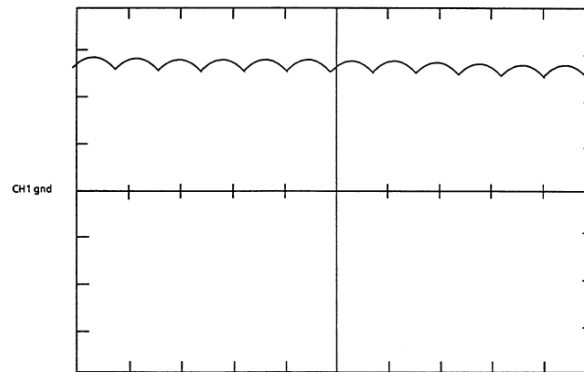

ATTENTION: Extreme care must be used when probing the test points on any board. Improper techniques may result in damage to the circuit and personal injury. Do Not attempt probe tests that are not listed here. Damage to extremely sensitive circuits may cause unpredictable drive operation and unintended motor rotation.

Figure 3.12 Field Current Feedback (TP25) - Continuous Current

Magnetics/Power Structure

The 1395 drive contains a power structure that has an armature and field supply. The armature supply consists of a three-phase, full wave rectified, dual bridge, capable of four quadrant output. The field supply consists of single phase, full wave rectified bridge. Also associated with the power structure are the low voltage logic power supply and the 24V unregulated power supply, contactor control circuits, and incoming line protection devices. The procedures below are designed to identify damaged components by standard troubleshooting techniques. Note that the troubleshooting information in this section is divided into two sections. All Series A troubleshooting information precedes Series B troubleshooting.

Series A

1-100 HP, 230V AC

2-200 HP, 460V AC

Armature SCR's (Series A)

The 1395 (1-100 HP, 230V AC & 2-200 HP, 460V AC) armature supply consists of six dual pack SCR modules mounted on the main heatsink. A malfunction of any of these devices will show itself in either an overcurrent related fault, blown or tripped incoming protection devices, or erratic motor operation. The following procedure can be used if an armature bridge component malfunction is suspected.

1. Disconnect and lock-out ALL incoming voltage sources. Verify that the three-phase high voltage is removed from the incoming protection devices, either F1 – F3 or the main circuit breaker CB1. Also verify that the 115V logic supply and contactor power is removed from TB2-3,4, and 5. If an external field supply is used, verify that it is also removed by checking TB1-1 and 5.
2. Check the Anode to Cathode junction of each SCR module. With a DVM on the 1 Megohm scale, measure the resistance across the SCR modules as follows: (Note: Lead orientation is not critical).

Figure 3.13 Series A SCR Layout

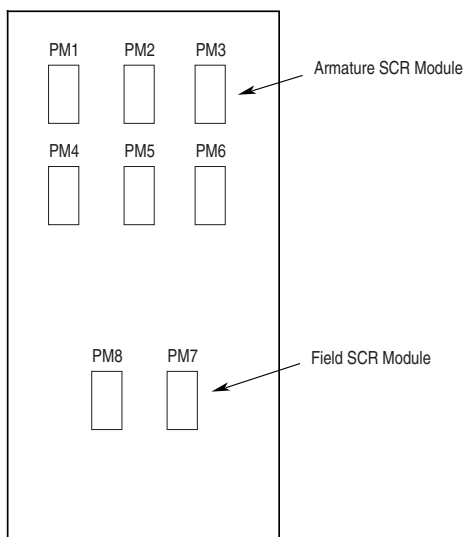

Module	Measurement Point
PM1	A1 (Bottom of DC contactor) to L1 (bottom of F1)
PM2	A1 (bottom of DC contactor) to L2 (bottom of F2)
PM3	A1 (bottom of DC contactor) to L3 (bottom of F3)
PM4	A2 (bottom of DC contactor) to L1 (bottom of F1)
PM5	A2 (bottom of DC contactor) to L2 (bottom of F2)
PM6	A2 (bottom of DC contactor) to L3 (bottom of F3)

All resistances should be 100k ohms or greater. If a low resistance is detected replace the affected SCR pack.

3. Check the gate to cathode junction of each SCR module. With the DVM on the 1K ohm scale, measure resistance of each junction as follows: (lead orientation is not critical)

Module	Measurement Points
PM1	G1 (Top of left arm/snubber board) to A1 (See above) G2 (Top of left arm/snubber board) to L1 (See above)
PM2	G1 (Top of middle arm/snubber board) to A1 (See above) G2 (Top of middle arm/snubber board) to L2 (See above)
PM3	G1 (Top of right arm/snubber board) to A1 (See above) G2 (Top of right arm/snubber board) to L3 (See above)
PM4	G1 (Bottom of left arm/snubber board) to A2 (See above) G2 (Bottom of left arm/snubber board) to L1 (See above)
PM5	G1 (Bottom of middle arm/snubber board) to A2 (See above) G2 (Bottom of middle arm/snubber board) to L2 (See above)
PM6	G1 (Bottom of right arm/snubber board) to A2 (See above) G2 (Bottom of right arm/snubber board) to L3 (See above)

All resistances should be between 7 to 30 ohms. If a measurement is outside of this range or if one reading deviates significantly from the majority, then module replacement may be necessary.

Armature Pulse/Snubber Boards (Series A)

The Armature Pulse/Snubber Boards provide isolation of the gate pulse firing circuit and also provide DV/DT protection for the SCR modules. A malfunction of these devices will be evident in either an overcurrent related fault, blown or tripped incoming protection devices, or erratic motor operation. Follow the procedure below if a board malfunction is suspected.

1. Disconnect and lock-out ALL incoming voltage sources.(See above)
2. Remove all three Pulse Boards by disconnecting the ribbon cable at J1. Remove the upper and lower gate leads at G1 and G2. Loosen the captive thumb screws designated DCA1, AC, and DCA2. Measure the following resistances with the DVM on the 200 ohms scale. (lead orientation is not critical)

Measurement Point	Measurement	J1 Pin Orientation
G1 (upper) to DCA1	100 ohms 10%	
G1 (lower) to DCA2		
G2 (upper) to AC (2L1)		
G2 (lower) to AC (3L1)		
D1 (anode) to DCA1	1 to 2 ohms	
D2 (anode) to AC (2L1)		
D3 (anode) to AC (3L1)		
D4 (anode) to DCA2		
J1-1 to J1-8	100 ohms 10%	
J1-2 to J1-8		
J1-3 to J1-8		
J1-6 to J1-8		

3. If any of these measurements (G1 through J6) are out of tolerance, replace the associated board. If these procedures check out and no apparent discrepancies are found, a potential problem could still exist. If a “breakdown path” has been established from the pulse transformer primary to secondary, it is possible that a malfunction could show itself when the line voltage potential is applied to the power structure. This condition can only be detected by “hi potting” the board at a level of 2500Vrms, and verifying less than 5mA from primary to secondary.

Field SCR's (Series A)

The 1395 field supply consists of two dual pack SCR modules arranged in a single-phase full wave rectifier configuration. Malfunction of any of these components may cause various responses including field and velocity related faults, or blown fuses at F4 and F6. The following procedures can be used if field bridge malfunctions are suspected.

1. Disconnect and lock-out ALL incoming voltage sources. Verify that the 3 phase high voltage is removed from the incoming protection devices, either F1 – F3 or the main circuit breaker CB1. Also verify that the 115V logic supply and contactor power is removed from TB2-3, 4, and 5. If an external field supply is used, verify that it is likewise removed by checking TB1-1 and 5.

2. Check the Anode to Cathode junction of each SCR module. With a DVM on the 1 Megohm scale, measure the resistance across the SCR modules as follows: (Note lead orientation is not critical). For Low kVA 1395

Measurement Point	Measurement
TB1-1 to TB2-1	greater than 500k ohms
TB1-5 to TB2-1	
TB1-1 to TB2-2	
TB1-5 to TB2-2	

If a measurement results in an “infinity” reading, check F4 and F6 for blown fuses.

3. Check the gate to cathode junction of each SCR module. With the DVM on the 1K ohm scale, measure resistance of each junction as follows: (lead orientation is not critical)

Loosen the four captive thumb screws on the feedback board and lift the board to gain access to the field pulse/snubber board. Remove the gate leads to the SCR modules. Measure the following resistances:

Module	Measurement Points	
PM7	G1 (left side of fld/snubber board) to TB2-1	G2 (left side of fld/snubber board) to TB2-2
PM8	G1 (right side of fld/snubber board) to TB1-5	G2 (right side of fld/snubber board) to TB1-1

All resistance measurements should be between 15 to 60 ohms. If the measurement is outside of this range or if a significant deviation among devices is measured, module replacement may be necessary.

Field Pulse/Snubber Boards (Series A)

The field pulse/snubber boards provide isolation of the gate pulse firing circuit and also provide DV/DT protection for the SCR modules. A malfunction of these devices will be evident in either an overcurrent related fault, blown or tripped incoming protection devices, or erratic motor operation. Follow the procedure below if a board malfunction is suspected:

1. Disconnect and lock-out ALL incoming voltage sources.(See above)

- Remove the pulse/snubber board by disconnecting the ribbon cable at J1 and remove the left and right gate leads at G1 and G2. Loosen the captive thumb screws and remove the printed circuit board. Measure the following resistances with the DVM on the 200 ohms scale. (Note lead orientation is not critical)

Measurement Point	Measurement	J1 Pin Orientation (Top View)
L1 to D3 (cathode)	100 ohms +/-10%	
L1 to D3 (anode)	1 to 2 ohms	
F1 to D4 (cathode)	100 ohms +/-10%	
F1 to D4 (anode)	1 to 2 ohms	
L3 to D2 (cathode)	100 ohms +/-10%	
L3 to D2 (anode)	1 to 2 ohms	
F1 to D1 (cathode)	100 ohms +/-10%	
F1 to D1 (anode)	1 to 2 ohms	
J1-1 to J1-9	60 ohms +/-10%	
J1-1 to J1-10	60 ohms +/-10%	

If any of these measurements are out of tolerance, replace the associated board. If the above procedure checks out and no apparent discrepancies are found, a potential problem could still exist. If a “breakdown path” has been established from the pulse transformer primary to the secondary, it is possible that a malfunction could show itself when the line voltage potential is applied to the power structure. This condition can only be detected by “hi potting” the board at a level of 2500V rms, and verifying less than 5 mA from primary to secondary.

115V Unit Power Supply (Series A)

The 115V Unit Power Supply sources the +5V, +12V, and +12V ISO logic power supplies used on the 1395 printed circuit boards. It is located on the fold down steel bracket, next to the PSI Board. A malfunction of this device will exhibit loss of functionality due to low or non-existent logic supplies, drive fault responses, and erratic operation. Follow the procedure below if a unit power supply malfunction is suspected.

- Measure the 115V AC source for the power supply. With the DVM on the 200V AC range, measure the voltage across J1 -5 and J1-6 on the PSI Board. (No convenient test points exist on the unit power supply, most measurements will be performed on the PSI board). If 115V AC cannot be detected, check fuse F8 located on the top panel. Remove all power prior to checking the condition of F8.
- Measure the outputs of the unit power supply. With the DVM on the 20 V DC range, measure the logic supply levels shown in [Table 3.A](#) referencing to TP5 (ground).

Important: If necessary, the 5V level can be adjusted with potentiometer R3, located on the Power Supply Board.

Table 3.B Logic Supply Levels

Test Point	Voltage	Low Limit	High Limit
TP1	+12V DC	+11.85V DC	+13.13V DC
TP2	+5.00V DC	+4.98V DC	+5.02V DC
TP4	-12V DC	-11.85V DC	-13.13V DC

If no logic voltages can be detected, check the condition of the fuse located on the unit power supply. Remove all power prior to checking the condition of the fuse. If the fuse is not open, replace the unit power supply.

3. Before replacing the unit power supply, disconnect and lock-out ALL incoming voltage sources. Verify that the 3 phase high voltage is removed from the incoming protection devices, either F1-F3 or the main circuit breaker CB1. Also verify that the 115V logic supply and contactor power is removed from TB2-3, 4 and 5. If an external field supply is used, verify that it is likewise removed by checking TB1-1 & 5.
4. Verify that the logic supplies also exist on the Main Control Board at the following test points:

Test Point	Measurement
TP51	+5V logic supply can be monitored with a DVM. Its signal level should be +5.00 VDC 0.02VDC in respect to TP52
TP52	Digital logic supply common can be monitored with a DVM. Its signal level should be +0V DC in respect to TE. This signal is used as the reference for measuring all isolated signals.
TP53	Isolated supply common can be monitored with a DVM. Its signal level should +0V DC in respect to TE. This signal is used as the reference for measuring all isolated signals.
TP54	Isolated +12V supply can be monitored with a DVM. Its signal level should be between 11.85 and 13.13 VDC in respect to TP53.
TP55	+12V logic supply can be monitored with a DVM. Its signal level should be between 11.85 and 13.13 VDC in respect to TP57.
TP56	-12V logic supply can be monitored with a DVM. Its signal level should be between 11.85 and 13.13 VDC in respect to TP57.
TP57	Analog supply common can be monitored with a DVM. Its signal level should be +0VDC in respect to TE. This signal is used as the reference for measuring all analog signals.
TP58	+5V isolated supply can be monitored with a DVM. Its signal level should be +5.00V DC 0.02 VDC in respect to TP53.

24V Internal Unregulated Supply (Series A)

The 24V unregulated power supply is used to supply power for SCR gate firing signals, the 24V ECOAST string, the pre-pilot relay, and the “faulted” relay. The components include a step-down transformer located under the top magnetics bracket, the rectifier and filter capacitors that are located on The PSI Board. A failure will exhibit a drive fault CP-15 “24V Power Supply Loss”. Follow the procedure below if a 24V power supply malfunction is suspected.

1. Measure the +24V supply level on the PSI Board. With the DVM on the 200V DC range, measure the potential from TP5 to TP23. The voltage should be 24V DC 6.0 V
2. Measure the 20V AC source for the 24V supply. With the DVM on the 200V AC range, measure across J2-9 and J2-10 on the PSI Board. The measured potential should be 20V AC 30%. If no potential is measured, check fuse F7 on the top panel. Remove all power prior to checking the condition of the fuse. If the potential is correct, replace the PSI Board.
3. If after replacing F7, the fuse still opens, replace the stepdown transformer 1PT. It is located on the back side of the magnetics bracket that mounts the incoming protection devices.

Magnetics Bracket Assembly Components

The magnetics bracket is located at the top of the drive. It includes TB1, TB2, F4 through F8, the pilot relay, 24V supply transformer, and 115V distribution block. The following procedures describe the remaining components, not already covered, and how to test them.

Disconnect and lock-out ALL incoming voltage sources prior to performing any of the tests below. Verify that the 3 phase high voltage is removed from the incoming protection devices, either F1 – F3 or the main circuit breaker CB1. Also verify that the 115V logic supply and contactor power is removed from TB2–3,4, and 5. If an external field supply is used, verify that it is likewise removed by checking TB1–1 and 5.

1. Fuses F4 through F6 are 25A rectifier type fuses. These fuses are a rejection style rectifier type fuse and are sensitive to their orientation in the fuse holders. The keyed end must be inserted downward in the fuse holder.
2. Fuse F7 provides protection for the 24V supply transformer. This fuse is a fragile glass type and caution should be exercised when handling it.
3. Fuse F8 provides protection for the 115V circuits. This fuse is a fragile glass type and caution should be exercised when handling it.
4. The pilot relay is located on the backside of the magnetics panel. Remove the wire harness at J1 on the PSI Board. With the DVM on the 20k ohm range, measure the resistance of J1–1 and J1–2 in the harness. It should be 3.5K ohms 10%.

5. The thermal switch is mounted in the middle of the main heat sink. In a normal, cool ambient, measure the resistance between TB1-17 and 18 on the Feedback board. The resistance should be less than 2 ohms.

Series B

1-30 HP, 230V AC

2-60 HP, 460V AC

Armature SCR's Series B

The 1395, 1-30 HP 230 VAC/ 2 - 60 HP 460VAC armature supply consists of six dual pack SCR modules mounted on the main heat sink. A malfunction of any of these devices will show itself in either an overcurrent related fault, blown or tripped incoming protection devices, or erratic motor operation. The following procedure can be used if an armature bridge component malfunction is suspected.

1. Disconnect and lock-out ALL incoming voltage sources. Verify that the three-phase high voltage is removed from the incoming protection devices, either F1 – F3. Also verify that the 115V logic supply and contactor power is removed from TB2-1, 2, 3. To gain access to the Power Board, swing down and remove PSI/Switcher Board.
2. Check the Anode to Cathode junction of each SCR module. With a DMM on the 1 Megohm scale, measure the resistance across the SCR modules as follows (refer to [Figure 3.14](#)).

Measure from . . .	To . . .
PM1	PM2
A1 (bottom of DC contactor)	L1 (bottom of F1)
A2 (bottom of DC contactor)	L1 (bottom of F1)
PM3	PM4
A1 (bottom of DC contactor)	L2 (bottom of F2)
A2 (bottom of DC contactor)	L2 (bottom of F2)
PM5	PM6
A1 (bottom of DC contactor)	L3 (bottom of F3)
A2 (bottom of DC contactor)	L3 (bottom of F3)

Figure 3.14 Series B SCR Layout

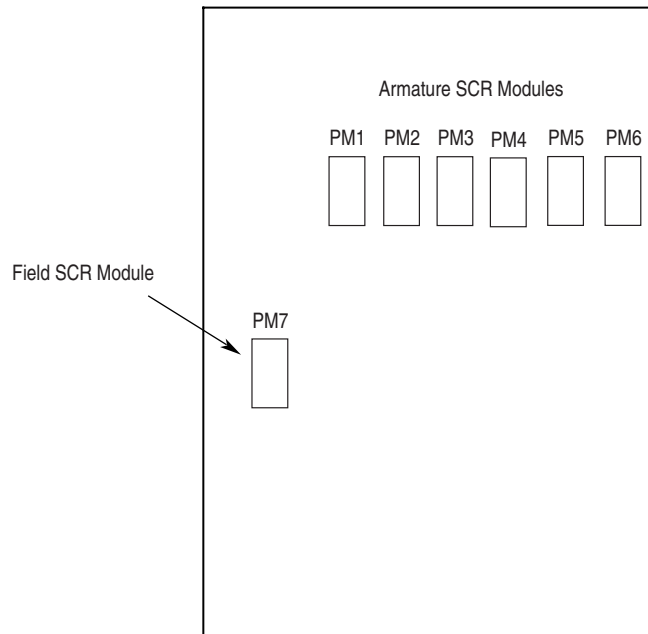

All resistances should be 100K ohm or greater. If a low resistance is detected, remove the power board and determine which of the power module pair is bad, replace it accordingly.

3. Check the Gate to Cathode junction of each SCR module. With a DMM on the 1K ohm scale, measure the resistance of each junction as follows:

From ...	To ...
PM1 – left SCR module G1 J15	A1 and G2 J16 to L1
PM2 – 2nd SCR module G1 J17	A2 and G2 J18 to L1
PM3 – 3rd SCR module G1 J19	A1 and G2 J20 to L2
PM4 – 4th SCR module G1 J21	A2 and G2 J22 to L2
PM5 – 5th SCR module G1 J23	A1 and G2 J24 to L3
PM6 – Right SCR module G1 J25	A2 and G2 J26 to L3

All resistances should be between 7 to 30 ohms. If measurement is outside of this range or one reading deviates significantly from the majority, module replacement may be necessary.

Armature Pulse/Snubber Circuits (Series B)

The Armature Pulse/Snubber Circuits located on the power board provide isolation of the gate firing circuit and also provide DV/DT protection for the SCR modules. A malfunction of these devices will be evident in either an overcurrent related fault, blown or tripped incoming protection devices or erratic motor operation. Use the following procedure if a malfunction in this circuitry is suspected.

1. Disconnect and lock out all incoming voltage sources. To Gain Access to the power board, swing down and remove PSI/Switcher Board.

- Remove the armature gate leads J15 thru J26. Measure the following resistances with a DMM on the 200 ohm scale.

Measurement Point	Measurement
J15 to A1 (bottom side of contactor) J16 to L1 J17 to A2 (bottom side of contactor) J18 to L1	100 ohms +/-10%
J19 to A1 (bottom side of contactor) J20 to L2 J21 to A2 (bottom side of contactor) J22 to L2	100 ohms +/-10%
J23 to A1 (bottom side of contactor) J24 to L3 J25 to A2 (bottom side of contactor) J26 to L3	100 ohms +/-10%
J6-6 to J6-1 J6-8 to J6-1 J6-9 to J6-1 J6-10 to J6-1 J6-11 to J6-1 J6-12 to J6-1 J6-13 to J6-1 J6-14 to J6-1 J6-15 to J6-1 J6-16 to J6-1 J6-18 to J6-1 J6-20 to J6-1	100 ohms +/-10%

If any of these measurements are out of tolerance, replace the power board.

Field SCR Module (Series B)

The 1395 Series B field supply consists of a single quad pack SCR module arranged as a single phase full wave rectifier. Malfunction of this component may cause various responses including field and velocity related faults, or blown F1 and F2 fuses. The following procedure can be used if field bridge malfunctions are suspected.

- Disconnect and lock out all incoming voltage sources. Verify the 3 phase high voltage is removed from the input fuses F1 - F3. Also verify the 115V logic and contactor power are removed from TB2 of the PSI/ Switcher board.
- To gain access to the power board, swing down and remove the PSI/ Switcher board.
- Remove all interconnects to the field bridge.

4. Check the gate to cathode junction of each SCR of the module as follows:
 Pin 6 to Pin 3
 Pin 7 to Pin 2
 Pin 8 to Pin 4
 Pin 9 to Pin 2

All resistance measurements should be between 15 and 60 ohms. If outside of this range or if significant deviation between SCR's is measured, module replacement may be necessary.

5. With the DMM on the 2 megohm range, check the anode to cathode junction of each SCR as follows:

Measurement Point	Measurement
Pin 2 to pin 3	greater than 500k ohms
Pin 2 to pin 4	
Pin 1 to Pin 4	
Pin 1 to Pin 3	

Field Pulse/Snubber Circuits (Series B)

The field pulse/snubber circuits, located on the power board, provide isolation of the gate firing circuit and also provide DV/DT protection for the SCR modules. A malfunction of these devices will be evident in either an overcurrent related fault, blown or tripped incoming protection devices or erratic motor operation. Follow the procedure below:

1. Disconnect and lock out all incoming voltage sources.
2. To gain access to the power board, swing down and remove the PSI/ Switcher board.
3. Remove the gate interconnects between the PCB and field SCR module (J11, J12, J13, J14).
4. Measure the following resistances with a DMM on the 200 ohm scale.

Measurement Point	Measurement
TB1-1 (L1) to D7 anode	1 to 2 ohms
TB1-1 (L1) to D7 cathode	100 ohms +/-10%
TB1-2 (L3) to D8 anode	1 to 2 ohms
TB1-2 (L3) to D8 cathode	100 ohms +/-10%
TB1-3 (F+) to D9 anode	1 to 2 ohms
TB1-3 (F+) to D9 cathode	100 ohms +/-10%
TB1-3 (F+) to D10 anode	1 to 2 ohms
TB1-3 (F+) to D10 cathode	100 ohms +/-10%
J6 - 1 to J6 - 19	60 ohms +/-10%
J6 - 1 to J6 - 17	60 ohms +/-10%

115V Switching Power Supply (Series B)

The 115V switching power supply sources the +5V, +/-12V, and the +12V ISO logic supplies used on the 1395 printed circuit boards. The power supply circuitry is located on the right side of the PSI/Switcher board. Failure of this circuitry will exhibit loss of functionality due to low or non-existent logic supplies, drive fault responses, and erratic operation. Follow the procedure below if a switching power supply malfunction is suspected:

1. Measure the 115VAC source for the power supply. With a DMM on the 200VAC range, measure the voltage across pins 2 and 3 of TB2 on the PSI/Switcher board. If 115V is not detected, check AC source. If 115V is detected, check the condition of F1, in the upper left hand corner of the PSI/Switcher board, and F3, to the left of TB2.
2. Measure the outputs of the supply on the test points located on the right side of the PSI/Switcher board. With a DMM on the 20VDC range, measure the logic supply levels shown in [Table 3.C](#) with reference to TP6.

Table 3.C Logic Supply Levels

Test Point	Voltage	Low Limit	High Limit
TP1	+12V DC	+11.85V DC	+13.13V DC
TP2	+5.00V DC	+4.98V DC	+5.02V DC
TP4	-12V DC	-11.85V DC	-13.13V DC

If the +5V is outside of the tolerance, adjust the trimmer potentiometer labeled R8 or 5V ADJ until it is inside specified tolerances. No independent adjustment is available for the other outputs.

3. Verify that the logic supplies also exist on the Main Control Board at the following test points:

Test Point	Measurement
TP51	+5V logic supply can be monitored with a DVM. Its signal level should be +5.00 VDC 0.02VDC in respect to TP52
TP52	Digital logic supply common can be monitored with a DVM. Its signal level should be +0V DC in respect to TE. This signal is used as the reference for measuring all isolated signals.
TP53	Isolated supply common can be monitored with a DVM. Its signal level should +0V DC in respect to TE. This signal is used as the reference for measuring all isolated signals.
TP54	Isolated +12V supply can be monitored with a DVM. Its signal level should be between 11.85 and 13.13 VDC in respect to TP53.
TP55	+12V logic supply can be monitored with a DVM. Its signal level should be between 11.85 and 13.13 VDC in respect to TP57.
TP56	-12V logic supply can be monitored with a DVM. Its signal level should be between 11.85 and 13.13 VDC in respect to TP57.
TP57	Analog supply common can be monitored with a DVM. Its signal level should be +0VDC in respect to TE. This signal is used as the reference for measuring all analog signals.
TP58	+5V isolated supply can be monitored with a DVM. Its signal level should be +5.00V DC 0.02 VDC in respect to TP53.

24V Unregulated Supply

The 24V unregulated power supply is used to supply power for SCR gate firing signals, the 24V ECOAST string, the pre-pilot relay, and the “faulted” relay. The components include a step-down transformer, rectifiers and filter capacitors located on the upper left side of the PSI/Switcher board. A failure will exhibit a drive fault CP-15 “24V Power Supply Loss”. Follow the procedure below if a 24V power supply malfunction is suspected.

1. Measure the +24V supply level on the PSI/Switcher Board. With a DMM on the 200 VDC range, measure the potential from TP25 to TP6. The voltage should be 24V DC \pm 6.0V
2. Measure the 20 VAC source for the 24V supply. With a DMM on the 200 VAC range, measure from cathode of D12 to the cathode of D13. The measured potential should be 20 VAC \pm 6VAC. If no potential is measured check fuse F2 on the PSI/Switcher board. If the AC potential is correct and there was no voltage measured in step 1, replace the PSI/Switcher board.
3. If after replacing F2, the fuse opens again, board replacement may be necessary.

Auto Tuning Malfunctions (Series A & B)

The Autotune function of the 1395 allows the user to tune the current and velocity loops in a minimum amount of time and effort. The Autotune function is executed using the Bulletin 1300 Programming Terminal and the standard logic control, dictated by the application. Most malfunctions that occur are indicated with a fault response from the 1395. The fault messages that are associated with Autotuning are VP-40 through VP-49 and CP-16, CP-18, CP-90 through CP-121. These fault messages are fully explained in Velocity Processor and Current Processor fault description sections.

Autotune measurement tests require the same considerations that normal operation does. Control of the drive ultimately is executed from the selected Logic Command. The parameters associated with Autotune must be properly programmed. The drive set-up parameters must be accurately programmed (i.e. Base Speed, Rated Armature Current Levels, Rated Field Current Levels, etc.) to allow for controlled and safe operation. All ECOAST and other related protective type circuits must be fully operational before attempting to use Autotune.

Using Trending to Aid Troubleshooting

General

The Trend function of the Bulletin 1395 allows the user to sample data in real time and store that data for examination or output. The Trend function can sample any source configuration parameter value in the 1395, at programmable sample rates, and output that data to the user through the Bulletin 1300 programming terminal or any of the adapter cards. This function can be very useful for capturing data that occurs in the Drive during a fault or malfunction. Through the use of a programmable trigger, data sampling can be triggered when a certain event occurs. Data before and after the trigger event is captured and stored. This data can then be used to examine the operating status during the trigger event.

Trend Programming

The Trend sample data consists of 100 consecutive data values that are stored when the programmed trigger conditions are met. The parameter to be sampled must be a configuration source that is linked to one of four trend configuration sink parameters, Parameter 50 “Trend 1 Input” through Parameter 53 “Trend 4 Input”. For example, if Parameter 106 “Velocity Fdbk” is the desired data to be sampled by trend 1, Parameter 50 “Trend 1 Input” should be linked to Parameter 106 “Velocity Fdbk”. All four trends can be active simultaneously, with no system degradation.

To define the trigger event information for each trend, set-up parameters are programmed by the user. For the above example involving Trend 1, parameters 910 to 917 must be programmed. The following paragraphs reference Trend 1. Trends 2 through 4 are programmed in the same way, using their associated parameters Trend 2 is programmed through parameters 920 - 927, Trend 3 through 930 - 937, and Trend 4 through 940 - 947.

The trigger event, which causes data to be sampled, is programmed by defining two operands and an operator. When the condition defined by the operator exists between the two operands the trend is triggered and the programmable data samples after the trigger are captured. The two operand parameters are selected by Parameter 910 “TR1 Opnd Param X” and Parameter 911 “TR1 Opnd Y” and can be programmed to all configuration and set-up parameters. The operator is defined in Parameter 912 “TR1 Operator”, the selections consist of:

Greater Than <.GT> - Compares the signed value of the parameter specified in Parameter 910 to Parameter 911. If the result of the comparison is positive, the trigger will occur.

Less Than <.LT> - Compares the signed value of the parameter specified in Parameter 910 to the signed value of the parameter specified in Parameter 911. If the result of the comparison is negative, the trigger will occur.

Equal <.EQ.> - Compares the signed value of the parameter specified in Parameter 910 to the signed value of the parameter specified in Parameter 911. If the result of the comparison is zero, the trigger will occur.

Not Equal <.NE.> - Compares the signed value of the parameter specified in Parameter 910 to the signed value of the parameter specified in Parameter 911. If the result of the comparison is a non-zero value, the trigger will occur.

And <.AND.> - Compares the bit(s) of a 16 bit parameter specified in Parameter 910 to the 16 bit(s) of the parameter specified in Parameter 911. If all of the SAME bit(s) are set to one in BOTH parameters, the trigger will occur. This is useful for triggering the trend based on the status bits of bit coded parameters such as Parameter 100 “Logic Status”, Parameter 101 “Drive Fault”, etc.

Negated And <.NAND.> - Compares the bit(s) of a 16 bit parameter specified in Parameter 910 to the 16 bit(s) of the parameter specified in Parameter 911. If all of the SAME bit(s) are set to zero in BOTH parameters, the trigger will occur. This is useful for triggering the trend based on the status bits of bit coded parameters such as Parameter 100 “Logic Status”, Parameter 101 “Drive Fault”, etc.

Or <.OR.> - Compares the bit(s) of a 16 bit parameter specified in Parameter 910 to the 16 bit(s) of the parameter specified in Parameter 911. If any or all of the same bit(s) are set to one in BOTH parameters, the trigger will occur. This is useful for triggering the trend based on the status bits of bit coded parameters such as Parameter 100 “Logic Status”, Parameter 101 “Drive Fault”, etc.

Nor <.NOR.> - Compares the bit(s) of a 16 bit parameter specified in Parameter 910 to the 16 bit(s) of the parameter specified in Parameter 911. If any or all of the same bit(s) are set to zero in BOTH parameters, the trigger will occur. This is useful for triggering the trend based on the status bits of bit coded parameters such as Parameter 100 “Logic Status”, Parameter 101 “Drive Fault”, etc.

Parameters 900 to 909 provide a convenient place to program trigger operand values. Signed values are programmed in parameters 900 to 903 “Trend Sign Val” and can range from 0 to +/-32767. Parameters 904 to 907 “Trend Logic Val” provide a bit adjustable parameter field for use with 16 bit parameter values. Parameters 908 and 909 “Trend Unsign Val” can range from 0 to 65535 for use in unsigned operations.

The sample rate for data sampling can be programmed through Parameter 913 “Tr1 Sample Rate”. It is programmable from 4ms to 30 seconds. The sample rate and the rate at which the trigger is evaluated are the same, up to 40ms. If the sample rate is longer than 40ms, the trigger will be evaluated every 40ms, but the data will be captured based on the sample rate.

The number of data samples taken after the trigger event is defined in Parameter 914 “TR1 Post Samples”. This parameter can be programmed from 0 to 99. Each trend always consists of 100 data values. If the number of post samples is less than 99, the remaining samples, minus 1 for the trigger sample, will be taken before the trigger event occurs. For example, if parameter 914 is programmed to 40 data samples, 59 samples will be taken prior to the trigger event, the trigger event will be one data sample, and 40 data samples will be sampled after the trigger.

The trend function can be programmed to trigger once and hold that data until the trend is enabled again, or it can be defined to capture data every time the trigger occurs. This selection is made in Parameter 915 “TR1 Cont Trigger”. If OFF is selected, the trend will be executed only once, upon the first trigger event. The trend will then be automatically disabled. The user must enable the trend for another trigger to be allowed. If ON is selected, multiple triggers will be allowed. Data sampling will occur with every trigger until the trend is disabled. Previous data will be overwritten.

Before the trend can be executed, it must be enabled. If Parameter 916 “TR1 Enable” is programmed ON, the trigger event will be honored and data will be sampled. If it is programmed to OFF, no data sample will occur. If no links have been made to the “Trend X Input” configuration parameters, the enable parameter will not allow ON to be programmed because no source for the trend has been defined.

Data gathered via a trend can be examined in various ways including the Bulletin 1300 Programming Terminal, PLC Block Transfer, PLC single I/O transfer, and the Discrete analog output channel.

Examining Trend Data With a Program Terminal

The Bulletin 1300 Programming Terminal uses main menu selection “8 Trend Files” to examine all data contained in a trend file. The next menu allows selection of the desired trend file. After selecting the trend file desired, the 1300 will retrieve the trend file information from the Bulletin 1395.

Under the “View Trend” menu header, the actual trend data values can be examined by selecting “1 - Trend Data”. The trend data is listed as data elements numbered 0-99. The value of the sampled data appears to the right of the data element number, and the time relative to the trigger, appears on the top of the display. Moving through the data list is accomplished by using various keys on the 1300 Programming Terminal.

Key	Description
<0>	Moves the cursor data to element 0.
<.>	Moves the cursor to data element 99.
<+/->	Locates the cursor on the trigger element.
<INC>	Moves the cursor ahead 10 elements.
<DEC>	Moves the cursor back 10 elements.
<up arrow>	Moves the cursor back 1 element.
<dn arrow>	Moves the cursor ahead 1 element.
<1>	Locates the cursor to the same element in Trend File 1

Key	Description
<2>	Locates the cursor to the same element in Trend File 2
<3>	Locates the cursor to the same element in Trend File 3
<4>	Locates the cursor to the same element in Trend File 4

The actual time that the trend trigger occurred can be examined by selecting “2 - Trigger Time”. The time is given in real time based on the system clock of the 1395. It is advised to setup the system time before running Trends or the time of the trigger will be meaningless.

A condensed description of the trend set-up and trigger information can be examined by selecting “3 - TR Operators”. The parameter being sampled and the trigger operators are displayed for reference.

Examining Trend Data with the Node Adapter

The PLC can access the Trend File information using Block Transfer. It requires 4 full messages to obtain an entire Trend File. The Block Transfer Class should equal 14 and the Element should equal 1. The first data word beyond the standard message header selects the Trend File number (1-4). The second word selects the data desired. Data file 0 contains the Trend File Setup data, while data file 1 contains Trend data values 0 to 33, data file 2 contains values 34 to 66, and data file 3 contains values 67 to 99.

Examining Trend Data with the Discrete Adapter

The analog output channel can be used to examine the Trend Data File by continuously outputting the trend data as an analog signal. This is especially useful when an analog type signal is being sampled by a trend. The trend output parameter, configuration source Parameter 1 “Trend 1 Output” through Parameter 4 “Trend 4 Output”, must be linked to an analog output configuration sink on the Discrete card.

When the trigger occurs and the data is sampled, the trend file will be output to the analog output channel. At the start of every data file output, a +/- 32767 data value will be output to mark the start of the data transfer. The data transfer will occur at the rate specified in Parameter 917 “TR1 Output Rate”. This value is programmable to allow for an output rate different than the actual sample rate. This is very useful for viewing the data in a condensed form when the actual sample rate is very long.

Examples of Trends

The following examples will illustrate how to program various Trend applications and how to utilize the captured data to aid in troubleshooting.

Example 1

The velocity profile being commanded is causing a production problem due to excessive torque required from the motor. The velocity profile will be captured and output to an analog channel anytime the torque command exceeds 50%

The necessary links for this application are:

Parameter 50 "Trend 1 Input" to Parameter 106 "Velocity Fdbk"
Parameter 451 "Analog Out 1" to Parameter 001 "Trend 1 Output".

The sample period for the trend file will be programmed to 8 ms per data point. The trigger will be programmed to occur when Parameter 110 "Torque Command" exceeds 50%. 50 data samples will be taken after the trigger. The necessary set-up parameter values for Trend File 1 are:

Parameter 901 "Trend Signed Val" = 2048 (50% per unit value)
Parameter 910 "TR1 Opnd Param X" = 110 (test operand)
Parameter 911 "TR1 Opnd Param Y" = 901 (constant operand)
Parameter 912 "TR1 Operator" = .GT. (110 greater than 901)
Parameter 913 "TR1 Sample Rate" = 0.008 (sample rate in sec.)
Parameter 914 "TR1 Post Samples" = 50 (# samples after trig)
Parameter 915 "TR1 Mult Trigger" = ON (multiple trig) Parameter 916
"TR1 Enable" = ON (enable trend)

Every time the torque command exceeds the 50% level, the velocity profile will be output to analog output channel 1 on the Discrete Card. This will allow the operator to identify the velocity profile sections that need to be reevaluated.

Example 2

The motor velocity exceeds the target velocity during acceleration to base speed. It cannot be determined if the reference is overshooting, or the gains of the velocity loop are causing the overshoot. A trend file will sample the final velocity reference and another trend will sample the velocity feedback. The necessary links for this application are:

Parameter 50 "Trend 1 Input" to Parameter 104 "Final Vel Ref"
Parameter 51 "Trend 2 Input" to Parameter 106 "Velocity Fdbk"

The data will be sampled at the fastest rate of 4ms to capture the velocity profile. This sampling rate will produce a 400 ms window of the Drives parameters. The trigger will be programmed to occur when the velocity reference exceeds base speed. The data samples will be set to capture 80 data values after the trigger and 19 before. The necessary links for this application are:

Parameter 900 "Trend Sign Val" = 4096 (per unit values)
Parameter 910 "Tr1 Opnd Param X" = 104 (test operand)
Parameter 911 "Tr1 Opnd Param Y" = 900 (constant operand)
Parameter 912 "Tr1 Operator" = .GT. (104 greater than 900)
Parameter 913 "Tr1 Sample Rate" = 0.004 (sample rate in sec)
Parameter 914 "Tr1 Post Samples" = 80 (# samples after trig)
Parameter 915 "Tr1 Mult Trigger" = OFF (single shot)
Parameter 916 "Tr1 Enable" = ON (enable trend)

The set-up parameters for the second trend will be identical to the first to allow real time comparison between the data samples. The necessary set-up parameter values for Trend File 2 are.

Parameter 900 "Trend Sign Val" = 4096 (per unit values)
Parameter 920 "Tr2 Opnd Param X" = 104 (test operand)
Parameter 921 "Tr2 Opnd Param Y" = 900 (constant operand)
Parameter 922 "Tr2 Operator" = .GT. (104 greater than 900)
Parameter 923 "Tr2 Sample Rate" = 0.004 (sample rate in sec)
Parameter 924 "Tr2 Post Samples" = 80 (# samples after trig)
Parameter 925 "Tr2 Mult Trigger" = OFF (single shot)
Parameter 926 "Tr2 Enable" = ON (enable trend)

When the Drive is accelerated to base speed the trend will trigger and the data will be captured. Use the Bulletin 1300 programming terminal to examine the data to determine which parameter exceeded the target velocity.

Example 3

Occasionally, the Drive faults on VP-15 "External Overtemp". The Drive's output at the time of the fault is unknown Trending will be used to determine what the operating conditions of the Drive were when the fault occurred. Motor velocity, torque command, and field flux effect the power and subsequent heat These parameters will be monitored and output to the Discrete Adapter analog output channels to examine the motor parameters prior to the fault. The necessary links for this application are:

Parameter 50 "Trend 1 Input" to Parameter 106 "Velocity Fdbk".
Parameter 51 "Trend 2 input" to Parameter 112 "Arm Current fdbk".
Parameter 52 "Trend 3 Input" to Parameter 118 "Fld Current Fdbk"
Parameter 451 "Analog Out 1" to Parameter 001 "Trend 1 Output"
Parameter 452 "Analog Out 2" to Parameter 002 "Trend 2 Output"
Parameter 453 "Analog Out 3" to Parameter 003 "Trend 3 Output"

The sample period for the trend files will be programmed to 10 secs per data point. The thermal time constant of most motors is quite large, the operating parameters will be captured for 16 minutes prior to the occurrence of the fault. The trigger will be programmed to occur when the fault occurs, the fault will be reported in Parameter 101 "Drive Fault" bit 5. All 100 data samples will be taken prior to the trigger. The necessary set-up parameter values for Trend File 1 Are:

Parameter 904 "Trend Logic Val" = 0000000000100000 (bit sel)
Parameter 910 "Tr1 Opnd Param X" = 104 (test operand)
Parameter 911 "Tr1 Opnd Param Y" = 904 (constant operand)
Parameter 912 "Tr1 Operator" = .EQ. (operator for bit 5)
Parameter 913 "Tr1 Sample Rate" = 10 (sample rate in sec)
Parameter 914 "Tr1 Post Samples" = 0 (# samples after trig)
Parameter 915 "Tr1 Mult Trigger" = OFF (single shot)
Parameter 916 "Tr1 Enable" = ON (enable trend)

The set-up parameters for the second and third trends will be identical to the first to allow real time comparison between the data samples. The necessary set-up parameter values for Trend File 2 and 3 are:

Parameter 904 "Trend Logic Val" = 0000000000100000 (bit sel)
Parameter 920 "Tr2 Opnd Param X" = 101 (test operand)
Parameter 921 "Tr2 Opnd Param Y" = 904 (constant operand)
Parameter 922 "Tr2 Operator" = .EQ. (operator for bit 5)
Parameter 923 "Tr2 Sample Rate" = 10 (sample rate in sec)
Parameter 924 "Tr2 Post Samples" = 0 (# samples after trig)
Parameter 925 "Tr2 Mult Trigger" = OFF (single shot)
Parameter 926 "Tr2 Enable" = ON (enable trend)

Parameter 904 "Trend Logic Val" = 0000000000100000 (bit sel)
Parameter 930 "Tr3 Opnd Param X" = 101 (test operand)
Parameter 931 "Tr3 Opnd Param Y" = 904 (constant operand)
Parameter 932 "Tr3 Operator" = .EQ. (operator for bit 5)
Parameter 933 "Tr3 Sample Rate" = 10 (sample rate in sec)
Parameter 934 "Tr3 Post Samples" = 0 (# samples after trig)
Parameter 935 "Tr3 Mult Trigger" = OFF (single shot)
Parameter 936 "Tr3 Enable" = ON (enable trend)

When the fault occurs the sampled data will be output to the analog channels. Analog Channel 1 will output the velocity feedback, analog channel 2 will output armature current feedback, and analog channel 3 will output field current feedback. The data can also be examined with the programming terminal.

System Considerations

When applying the 1395 Drive in system applications, certain precautions and good design practices should be followed. Special ground considerations must be taken to provide a low noise environment that reduces Drive malfunctions and enhances the reliability of the system. Likewise the Drive should be kept clean and free from foreign material contamination. Air flow around the Drive and system cabinet should not be restricted, but be allowed to circulate clean air from proper cooling. By following these considerations system malfunctions can be minimized.

Ground Network Considerations

Several ground connections are provided on the 1395 controller and each serves a specific function. Overall the grounding should be configured in a Star type arrangement. All devices in the system should be directly tied to a central low impedance point source. Avoid daisy chained ground connections where ground connections are run from device to device before it is connected to the low impedance source. For specific grounding information for your drive, refer to the Hardware and Installation chapters in the 1395 Installation Manual.

Electrical Noise Control

The system grounding configuration largely effects the integrity, and quality of the controllers logic and low level analog signals. Other factors which effect signal quality, and thus the integrity of the entire system, must also be considered when troubleshooting 1395 systems.

Separation of low level control and high level switching / power conductors must be maintained. Analog Reference signals, feedback signals (either analog or digital), and serial communication wiring must be separated from 115V AC relay logic and any power wiring (brake, armature, field, external relay wires, etc.). When wiring both inside and outside the 1395 system cabinets it is desirable that low level signals be run in separate conduits from power wiring. Shielded conductors must be used for all low level analog signals, serial communication, and digital feedback signals (encoder). This shielded cable should be of twisted pair type construction with the shield tied to ground at the source end of the cable. The 1395 provides a shield bus connection TB4 at the bottom of the controller for shield connections.

All inductive switching devices should be suppressed, at the device, to decrease the DV/DT noise that is generated. A high rate of voltage change in a conductor will induce a current in an adjoining coupler through capacitive coupling. Two factors effect the amount of current induced:

1. The rate of change in voltage.
2. The relative distance between conductors.

By controlling both of these factors, induced system noise should be minimized. This should help guard against nuisance faults and reduce stress on CMOS devices used in the 1395 controller.

Manually Tuning the 1395 Drive

Introduction

This chapter provides the basic guidelines for manually tuning the 1395 Drive. Procedures performed in this chapter include the following:

- Current loop tuning
- Velocity loop tuning
- Field Flux tuning



ATTENTION: Only qualified Allen-Bradley Personnel familiar with the Bulletin 1395 Drive system and the associated machinery should attempt to manually tune the Drive. Failure to comply may result in personal injury and/or equipment damage.

Tools & Test Equipment

In addition to a Bulletin 1300 Programming Terminal the following should be available before attempting to manually tune the Drive:

- Digital Volt Meter
- Discrete Adapter Board
- Oscilloscope - A digital storage scope is preferred, but an analog scope can be used.

Current Loop Tuning

The following steps command an armature current reference in order to determine the level at which armature current just reaches continuous conduction. This value is then used to calculate Kp (proportional gain) and Ki (integral gain) of the current loop. The following instructions are provided to “fine tune” the AC line and Armature voltage sensing.

This procedure assumes that a Discrete Adapter Board is located in the left port (port A). If the Discrete board is in Port B, parameters must be adjusted accordingly.



ATTENTION: As a safety precaution, have available an “ECOAST” switch to disable the drive in the event of inadvertent motor rotation. If possible, disconnect or disengage the motor shaft from the machine and “lock” the motor shaft.

1. Monitor TP2 - Current Feedback
2. Set Accel & Decel rates to 0.1 sec.
3. Set FWD & REV Current Limits to 15%

4. Start Drive & Accel to Base Speed while observing current feedback on the oscilloscope.
5. Increment or Decrement the current limit values until just continuous current is observed. Continuous current is the point where the current feedback does not sit at zero for any period of time between current pulses. Once continuous current is reached, note the value of parameter 110 (Torque Command) and stop the Drive. Note the value of parameter 110.
6. Take the value from Step #5 and multiply it by the ratio of the values of parameter 611 and 615 and then multiply by 1024.
Parameter 110 x (Parameter 611/Param615) x 1024.
This decimal number will represent the percentage of rated motor current where continuous current is reached. Enter this number in Parameter 734K_Discontinuous.
7. Calculate: Kp parameter 735 = 746000/K Disc. Enter this value in the Programming Terminal.
Calculate: Ki parameter 736 = 137000/K Disc. Enter this value in the Programming Terminal.
8. Initial values must be entered for the armature voltage and A.C. line sensing scaling.
For 150-300 Input Voltage:
Parameter 739 (K ARM Volts) = 6414
Parameter 740 (K AC Volts) = 7473
With line voltage applied, monitor the incoming voltage with a DVM and fine tune parameter 740. Parameter 740 should be trimmed so parameter 116 (AC Line Voltage) matches the value read on the DVM.
With the drive running the motor at some constant speed (preferably greater than 1/2 of base speed), monitor the armature voltage with a DVM and fine tune parameter 739 so parameter 105 (Arm Voltage Fdbk) matches the value read on the DVM.
9. With the Drive in a stopped state, delete any changes to the Drive configuration (through Drive set-up) and return the Drive set-up to its original configuration (torque mode parameter 625 and external torque reference, link 157 to 401).
Perform an EEPROM burn and verify the above parameter changes have been successfully stored.

Velocity Loop Tuning

The three parameters which are used to tune the Velocity Loop include:

- Parameter 659 (KI Velocity Loop) - Integral gain term; This parameter is scaled so that a value of 8 represents a gain of 1. This value will effect the time recovery response to a velocity disturbance or reference change so that, a reference change of 1 per unit will produce 1 per unit velocity error.
- Parameter 660 (KP Velocity Loop) - Proportional gain term; This parameter is scaled so that a value of 8 represents a gain of 1. This value will effect the magnitude response to a velocity disturbance or reference change, so that a reference change of 1 per unit will produce 1 per unit velocity error.
- Parameter 661 - KF Velocity Loop - Velocity reference proportional trim term; This parameter represents some level of attenuation to the velocity reference used in the proportional gain calculation. 65365 is a gain of 1, and 0 is a gain of 0. The portion of KF specified will cause the velocity regulation to be “finished” by the integral term only, this can be seen in the following formula:

$$(\text{Pos Ref} - \text{Pos Fdbk}) \times \text{KI} + (\text{Vref} \times \text{KF} - \text{Vfdbk}) \times \text{KP} = \text{Vel Error.}$$

Where: Pos Ref => Position Reference (integrated velocity reference)

Pos Fdbk => Position Feedback (integrated velocity feedback)

Vref => Velocity reference

Vfdbk => Velocity Feedback

Vel Error => Velocity error (current loop reference)

If $\text{KF} = 0.7 = 45874$; as velocity feedback reaches 70% of velocity reference, KP begins to have a negative feedback effect, causing the Integral term KI to be responsible for finishing the regulation. The net effect of this activity is to cause an overdamped response, ie: No Overshoot.

Practical value range and initial settings:

Armature Voltage Feedback

KP => 20 to 100 Initial setting 15

KI => 30 to 500, Initial setting 60

KF => 32767 to 65535, Initial setting 45874

D.C. Tachometer Feedback

KP => 50 to 250, Initial setting 64

KI => 100 to 2500, Initial setting 256

KF => 32767 to 65535, Initial setting 45874

Encoder Feedback

KP => 50 to 350, Initial setting 100

KI => 250 to 10,000, Initial setting 400

KF => 32767 to 65535, Initial setting 65535

These values and ranges represent typical values, and actual system requirements will vary greatly depending on influences such as system inertia, system friction, smoothness of load and “noise” on the feedback signal. In general, the values can be set at these initial settings depending on the feedback device, and can be tuned as follows:

KP - KP can be adjusted by observing the drives current feedback signal at Test Point 2 on the Main Control Board. With the system running at set speed, adjust KP until uneven current pulses are observed (greater than 250mv variance in pulse to pulse height).

KI/KF - KI can be adjusted by making small step response tests to the system. If machine dynamics require a prescribed accel/decel rate, 'run the drive from zero speed to about 1/4 speed and vice versa.If possible, link parameter 106 (velocity feedback) to an analog output and observe the machine or motor shaft for movement.If overshoot exists or an excessively long period is required for the shaft to stop, adjust KI until minimal overshoot exists. If overshoot cannot be totally removed, adjust KF to attain the desired response.

Field Flux Tuning

This procedure involves setting up the Field Flux Table (parameters 677 through 684) and the rated motor field current (parameter 612) based on the actual motor characteristics.

1. Record the value of the field flux reference (parameter 676) and the field economy reference (Parameter 674) below:

Parameter 674 _____

Parameter 676 _____

2. Set the field flux reference and the field economy reference to 100%

Important: The drive start command must remain true for the entire time the test is being performed. If a stop command is issued anytime during the test, the motor will stop and the test will be aborted. Check parameter 624 (maintain start) to determine if the start command is latched or momentary.

3. Start the Drive and run it at the same speed as specified by parameter 699.
4. Select the Field Flux Tune option using the programming terminal.
5. The Field Flux tuning will begin. It takes approximately 5 to 60 seconds for the test to complete, at which time the program terminal will indicate that the test has been completed.
6. Set the field flux reference and the field economy reference back to their original values as recorded in step 1.



ATTENTION: Failure to set the field economy reference back to its original value may cause damage to the motor field. Certain motors will not tolerate full field while at zero speed for prolonged periods of time.

Test Points

General

This chapter is intended to define the 1395 test points on the major boards to help you troubleshoot the drive. A table of normal values for each test point on each board is provided.

Main Control Board

The 1395 Main Control Board test points are common to all drive ratings.

Table 6.A Main Control Board Test Points

Test Point	Normal Value	Description
1	Not Used	Not Used
2	Full-wave rectified waveform from Power Stage Interface Board, 2 volts = Rated Armature Bridge Current (refer to parameter 615).	ABSIA signal from Power Stage Interface representing armature current feedback as sensed by CTs on incoming 3 phase AC line.
3	Not Used	Not Used
4	DC Voltage between 0 and +5V DC.	Three-phase supply signal derived from half-wave rectification of the 3 phase line to line voltages.
5	DC volts between 0 and +5V DC. Full wave rectified three-phase waveform.	DC voltage representing armature current feedback derived from the ABSIA signal. DC voltage is scaled so that 4V DC represents 2 times full rated DC output bridge current. See parameter 615, Rated Armature Bridge Current.
6	0V DC when armature current is zero, +5V DC when armature current is not zero.	CURRZERO (NOT) signal used as a logic input to the current control firmware for zero current detection. This is a latched signal.
7	Not Used	Not Used
8	0V DC when phase loss detected, +5V DC otherwise.	PHASE LOSS (NOT) signal used as a logic input to the current control firmware for phase loss detection. This is a latched signal.
9	0V DC when no DC overcurrent exists, +5V DC when a DC overcurrent exists.	Output from overcurrent logic for DC current fault detection.
10	Sawtooth type waveform varying between 0 and +5V DC.	ARMCURRINTG signal representing the output of the Charge Balance current feedback circuit used to provide armature current feedback information for control of armature current.
11	Not Used	Not Used
12	0 to +5V square-wave	ENCB signal indicating the frequency of the B channel encoder feedback.
13	0 when encoder test is enabled, +5V DC when encoder test is disabled (+5V DC for normal operation).	ENCEN signal used to enable the injection of an encoder test signal to the encoder feedback circuit. ENCEN is logic 1 when the test operation is disabled and the normal operation of the encoder feedback signal is enabled.
14	DC voltage between 0 and +10V DC.	DC voltage representing DC armature current as sensed by the DC current sensing device. DC voltage scaling is set so that 8V DC represents 4 times full rating of the armature bridge (this is the trip level). This signal is used only for DC overcurrent detection.

Test Point	Normal Value	Description
15	0 to +5V DC square wave	ENCA signal indicating the frequency of the A channel encoder feedback.
17	+5VDC when phase loss exists. 0V DC when no phase loss exists.	PHASELOSS signal used as input to the phase loss latch circuit, the output of which is sent to the drive logic.
19	0V DC when measured with respect to TE ground.	Analog ground test point. All analog signals on the Main Control Board must be measured with respect to analog ground.
20	+1.5V DC to +3.0V DC for nominal value.	POWERSUPPLY signal used to monitor the status of the DC supply voltages.
21	DC volts between 0 and +10V DC.	DC voltage representing armature voltage feedback.
23	0 to +5V, 6 pulse	Pulses representing 4x encoder frequency in reverse, otherwise 0.
24	Full wave rectified DC volts between 0 and -3V DC single wave.	IFFB signal from Power Stage Interface represents field current feedback as sensed by FCT. -3V DC equals the maximum value of the range specified by the J1 jumper position.
25	DC voltage between 0 and +5V DC.	DC voltage representing field current feedback derived from the IFFB signal. DC voltage scaling is set so 3.0V DC represents maximum value of the range specified by the J1 jumper position.
26	DC voltage between 0 and +5V DC.	DC voltage representing armature voltage feedback. 2.5V DC equals 0V DC armature voltage feedback.
27	DC voltage between 0 and +5V DC.	DC voltage representing armature voltage feedback. TP 26 filtered.
28	0 V DC when no AC overcurrent exists. +5 V DC when an AC overcurrent exists, unlatched.	OCAC signal used as a logic input to the overcurrent latch circuit and to the drive logic.
29	0V DC when overcurrent latch circuit is not latched. +5V DC when overcurrent latch circuit is latched	AC and DC overcurrent signals used as input to the drive logic. Once an overcurrent condition has occurred, the output of the latch circuit is held high until a drive reset has occurred.
30	0 to +5V square wave with varying period	SYNCHAB (NOT) signal used as input to the synchronizing circuit to determine phase rotation.
31	+5V DC when contactor is open.	SYSTRIP signal used to open Main Contactor when overcurrent has been sensed.
33	0 to +5V square wave with varying period.	Signal used to reset the charge balance current feedback circuit used for armature current feedback.
34	0 when resetting, +5V DC for charging.	Armature current integrator reset signal.
35	0 to 5V DC Pulse	4 times encoder frequency (signal not direction sensitive).
36	0 to 5V DC Pulse	4 time encoder frequency signal in forward direction, 0 in other cases.
37	+5V DC when overcurrent latch circuit is not latched. 0V DC when latched.	Inverse of OVERCURRENT signal measured at TP29. Used as input to the system inhibit circuit.
38	0 to +5V DC square-wave representing the inverse of the line D to C waveform.	SYNCHBC (NOT) signal used as input to the synchronizing logic to determine phase rotation.
39	0V DC when system operation is not inhibited. +5V DC when inhibited.	SYSINHIBIT signal used in drive logic to open DC contactor.
41	0 to +5V DC. Trip Point at 2.6V DC.	24V DC power supply sense. Drive faults at less than 2.6V DC.
43	0V DC when coast stop command is not received. +5V DC when received.	ECOAST signal used in drive logic to control operation after coast stop command.
51	+5, +0.02V DC when measured with respect to TP52.	Digital circuit power supply voltage.
52	0V DC when measured with respect to TE signal ground.	Digital Ground. All logic signals must be measured with respect to TP52.

Test Point	Normal Value	Description
53	0V DC when measured with respect to TE signal ground.	Isolated Ground. All isolated signals must be measured with respect to TP53.
54	+12 (11.85 / 13.13)V DC when measured with respect to TP53.	Isolated +12V DC analog voltage supply
55	+12 (11.85 / 13.13)V DC when measured with respect to TP57.	+12V DC analog voltage supply.
56	-12 (-11.85 / -13.13)V DC when measured with respect to TP57.	+12V DC analog voltage supply.
57	0V DC when measured with respect to TE.	-12V DC analog voltage supply.
58	+5, +0.02V DC measured with respect to TP53.	Analog Ground. All signals must be measured with respect to TP57. Isolated +5V DC supply voltage.

Power Stage Interface/ Switcher Board

Table 6.B Series B Drives Rated 1-30 HP, 230V AC & 2-60 HP, 460V AC.

Test Point	Normal Value	Signal Description
1	12V DC (11.85/13.13)	12V DC Power Supply
2	+5V DC when field firing is enabled	FFIREEN signal from Main Control Board
3	0V DC	Not Used
4	+12, (+11.85/13.13)V DC	+12V DC Power Supply
5	+24, ±6.0V DC	+24V DC Power Supply
6	+5V DC when armature firing is enabled	AFIREEN signal from Main Control Board
7	Test points TP7-TP20 are used to monitor the gate pulses to the armature and field SCRs. The observed signal for these test points will be a square wave, +24V to 0V DC, 120 degrees On & 240 degrees Off when the particular SCR is being fired.	Bridge Armature; SCR 1F
8		Bridge Armature; SCR 5F
9		Bridge Armature; SCR 3F
10		Bridge Armature; SCR 4R
11		Bridge Armature; SCR 2R
12		Bridge Armature; SCR 6R
13		Field; FLD1
14		Armature; 2F
15		Field; FLD2
16		Armature; 4F
17		Armature; 5R
18		Armature; 6F
19		Armature; 1R
20	Armature; 3R	
21	0V DC when Relay K3 is energized	Control Signal to K3
22	+5, (±0.02V DC)	+5V DC power supply
23	+0, +0V DC	Control common (TE signal ground)

Power Stage Interface Board Table 6.C Series A Drives Rated 40-100 HP, 230V AC & 75-200 HP, 460V AC

Test Point	Normal Value	Signal Description
1	12VDC (11.85/13.13)	12V DC Power Supply
2	+5V DC when field firing is enabled	FFIREEN signal from Main Control Board
3	0V DC	Not Used
4	+12, (+11.85/13.13)V DC	+12V DC Power Supply
5	+24, ±6.0V DC	+24V DC Power Supply
6	+5V DC when armature firing is enabled	AFIREEN signal from Main Control Board
7	Test points TP7-TP20 are used to monitor the gate pulses to the armature and field SCRs. The observed signal for these test points will be a square wave, +24V to 0V DC, 120 degrees On & 240 degrees Off when the particular SCR is being fired.	Bridge Armature; SCR 1F
8		Bridge Armature; SCR 5F
9		Bridge Armature; SCR 3F
10		Bridge Armature; SCR 4R
11		Bridge Armature; SCR 2R
12		Bridge Armature; SCR 6R
13		Field; FLD1
14		Armature; 2F
15		Field; FLD2
16		Armature; 4F
17		Armature; 5R
18		Armature; 6F
19		Armature; 1R
20		Armature; 3R
21	0V DC when Relay K3 is energized	Control Signal to K3
22	+5, (±0.02V DC)	+5V DC power supply
23	+0, +0V DC	Control common (TE signal ground)

Table 6.D Series B Drives Rated 125-300 HP, 230V AC & 250-600 HP, 460V AC

Test Point	Normal Value	Signal Description
1	12V DC (11.85 / 13.13)	12VDC Power Supply
2	0V DC when relay K3 is energized	Control signal to K3
3	0V DC	Control common (TE signal ground).
4	+5 ±0.02V DC)	+5V DC power supply
5	+12 (11.85 / 13.13)V DC	+12V DC power supply
6	+24, ±6.0)V DC	+24V DC power supply
7	+5V DC when armature firing is enabled.	AFIREEN signal from Main Control Board
8	Not Used	Not Used
9	+5V DC when field firing is enabled	FIREEN signal from Main Control Board

Power Supply Board

Table 6.E Series A Drives Rated 40-100 HP, 230V AC & 75-200 HP, 460V AC or Series B Drives Rated 125-300 HP, 230V AC & 250-600 HP, 460V AC

Test Point	Normal Value	Signal Description
1	+12V DC (11.85 / 13.13)	+12V DC Power Supply
2	+5V DC ±0.02V DC)	+5V DC Power Supply
3	Internal use	
4	12V DC (11.85 / 13.13)	12V DC Power Supply
5	0V DC	Control Common (TE Signal Ground)

Parameter List/Record

General Checklist

Drive Nameplate Data

Drive Order Number: _____

Catalog Number: _____

S/N: _____

Ser: _____

AC Input Field _____ Volts _____ Amps

AC Input Armature _____ Volts _____ Amps

DC Output Field _____ Volts _____ Amps

Wiring and Control Board Checks

- All wiring and cabinets are properly grounded.
- If used, isolation transformer is properly installed, wired and grounded.
- All standard drive control wiring is correct per the figures in Chapter 5 of the 1395 Installation & Maintenance Manual.
- All control board jumpers are in correct position per the tables in Chapter 5 of the 1395 Installation & Maintenance Manual.
- All peripheral control devices are wired correctly per instructions in the appropriate Adapter Board I&O Manual.

Measurement Record

Important: Record any values that are changed or modified.

Table A.A Voltage Measurements

Test Points	Expected Voltage	Measured Voltage
AC Voltages		
L1 to L2	Rated AC Input	
L2 to L3	Rated AC Input	
L3 to L1	Rated AC Input	
TB11 to TB15 (3.6A 345A Drives Only)	Rated AC Field Input	
TB51 to TB55 (346A 980A Drives Only)	Rated AC Field Input	
TB24 to TB25	115V AC, $\pm 10\%$	
Main Control Board		
TP51 to TP52	+5V, $\pm 0.15V$ DC	
TP55 to TP57	+12V, $\pm 0.48V$ DC	
TP56 to TP57	12V, $\pm 0.48V$ DC	
TP58 to TP53	+5V, $\pm 0.15V$ DC	
TP54 to TP53	+12V, $\pm 0.48V$ DC	
Power Stage Interface Board:		
TP5 to TP23 (3.6A 345A Drives Only)	+24V, $\pm 6V$ DC	
TP6 to TP3 (346 980A Drives Only)	+24V, $\pm 6V$ DC	

Parameter Record

Table A.B Fast Source Parameter List

Parameter Number	Description	Default Value	Linked To Parameter
1	TREND 1 OUTPUT		
2	TREND 2 OUTPUT		
3	TREND 3 OUTPUT		
4	TREND 4 OUTPUT		
10	SP OUTPUT 1		
11	SP OUTPUT 2		
12	SP OUTPUT 3		
13	SP OUTPUT 4		
14	SP OUTPUT 5		
50	TREND 1 INPUT		
51	TREND 2 INPUT		
52	TREND 3 INPUT		
53	TREND 4 INPUT		
100	LOGIC STATUS		
	BIT 0 = FAULT FIELD 0		
	BIT 1 = FAULT FIELD 1		
	BIT 2 = ACTIVE LOGIC COMMAND 0		
	BIT 3 = ACTIVE LOGIC COMMAND 1		
	BIT 4 = CONTACTOR CLOSE		
	BIT 5 = DRIVE RUNNING		
	BIT 6 = RUNNING REVERSE		
	BIT 7 = READY		
	BIT 8 = AT CURRENT LIMIT		
	BIT 9 = SET SPEED		
	BIT 10 = AT ZERO SPEED		
	BIT 11 = AT SPEED 1		
	BIT 12 = AT SPEED 2		
	BIT 13 = AT SPEED 3		
	BIT 14 = AT SPEED 4		
	BIT 15 = AT SPEED 5		
101	DRIVE FAULT		
102	PRE RAMP VELOCITY REFERENCE		
103	RAMP VELOCITY REFERENCE		
104	FINAL VELOCITY REFERENCE		
105	ARMATURE VOLTAGE FEEDBACK		
106	VELOCITY FEEDBACK		
107	POSITION FEEDBACK		
108	VELOCITY FEED FORWARD		
109	POSITION ERROR		
110	TORQUE COMMAND		
111	ARMATURE CURRENT REFERENCE		
112	ARMATURE CURRENT FEEDBACK		
113	ARMATURE CURRENT PI OUTPUT		
114	ARMATURE CURRENT FIRING ANGLE		
115	FLUX COMMAND		
116	AC LINE COMMAND		
117	FIELD CURRENT REFERENCE		
118	FIELD CURRENT FEEDBACK		
119	PROCESS TRIM OUTPUT		

Table A.C Fast Sink Parameters

Parameter Number	Description	Default Value	Linked To Parameter	
150	LOGIC COMMAND 1			
	BIT 0 = RUN REFERENCE A			
	BIT 1 = RUN REFERENCE B			
	BIT 2 = RUN REFERENCE C			
	BIT 3 = MOP INCREMENT			
	BIT 4 = MOP DECREMENT			
	BIT 5 = RAMP DISABLE			
	BIT 6 = MOP RATE 1			
	BIT 7 = MOP RATE 2			
	BIT 8 = AUTO/MANUAL			
	BIT 9 = JOG 2			
	BIT 10 = JOG 1			
	BIT 11 = NORMAL STOP			
	BIT 12 = START			
	BIT 13 = CLOSE CONTACTOR			
	BIT 14 = CLEAR FAULT			
BIT 15 = PROCESS TRIM				
151	LOGIC COMMAND 2			
	BIT 0 = RUN REFERENCE A			
	BIT 1 = RUN REFERENCE B			
	BIT 2 = RUN REFERENCE C			
	BIT 3 = MOP INCREMENT			
	BIT 4 = MOP DECREMENT			
	BIT 5 = RAMP DISABLE			
	BIT 6 = MOP RATE 1			
	BIT 7 = MOP RATE 2			
	BIT 8 = AUTO/MANUAL			
	BIT 9 = JOG 2			
	BIT 10 = JOG 1			
	BIT 11 = NORMAL STOP			
	BIT 12 = START			
	BIT 13 = CLOSE CONTACTOR			
	BIT 14 = CLEAR FAULT			
BIT 15 = PROCESS TRIM				
152	LOGIC COMMAND 3		200	
	BIT 0 = RUN REFERENCE A		DHT Parameter 200 Hard Linked	
	BIT 1 = RUN REFERENCE B			
	BIT 2 = RUN REFERENCE C			
	BIT 3 = MOP INCREMENT			
	BIT 4 = MOP DECREMENT			
	BIT 5 = RAMP DISABLE			
	BIT 6 = MOP RATE 1			
	BIT 7 = MOP RATE 2			
	BIT 8 = AUTO/MANUAL			
	BIT 9 = JOG 2			
	BIT 10 = JOG 1			
	BIT 11 = NORMAL STOP			
	153	LOGIC COMMAND 1		
154	BIT 0 = RUN REFERENCE A			

Parameter Number	Description	Default Value	Linked To Parameter
156	BIT 1 = RUN REFERENCE B		
157	BIT 2 = RUN REFERENCE C		
159	BIT 3 = MOP INCREMENT		
160	BIT 4 = MOP DECREMENT		
161	BIT 5 = RAMP DISABLE		
162	BIT 6 = MOP RATE 1		
163	BIT 7 = MOP RATE 2		
164	BIT 8 = AUTO/MANUAL		
165	BIT 9 = JOG 2		
166	BIT 10 = JOG 1		

Table A.D Parameter Values

Parameter Number	Description	Value	PLC Reference
600	VELOCITY PARAM 1 SEL (PAR 163)		
601	VELOCITY PARAM 2 SEL (PAR 164)		
602	VELOCITY PARAM 3 SEL (PAR 165)		
603	VELOCITY PARAM 4 SEL (PAR 166)		
606	BASE MOTOR SPEED		
607	REVERSE SPEED LIMIT		
608	FORWARD SPEED LIMIT		
609	ENCODER PPR		
610	RATED MOTOR VOLTAGE		
611	MOTOR ARMATURE FLA		
612	RATED FIELD MOTOR CURRENT		
613	MOTOR INERTIA		
614	ARMATURE RESISTANCE		
615	RATED ARMATURE BRIDGE CURRENT		
616	RATED FIELD BRIDGE CURRENT		
617	RATED AC LINE VOLTAGE		
620	SYSTEM RESET SELECT 0 = SYSTEM RESET 1 = NORMAL STOP		
621	FEEDBACK DEVICE TYPE 0 = ENCODER 1 = ARMATURE VOLTS 2 = ANALOG TACH 3 = NO FDBK		
622	CONTACTOR TYPE AC = 0 (INTERRUPTS AC SUPPLY) DC = 1 (INTERRUPTS DC ARM CIRCUIT)		
623	HARD FAULT SELECT BIT 0 = SCR OVERTEMP BIT 1 = MOTOR OVERTEMP BIT 2 = OVERLOAD TRIP BIT 3 = STALL BIT 4 = AC VOLTAGE OUT OF TOLERANCE BIT 5 = WAITING SAFE ARM VOLTS BIT 6 = WAITING ZERO CURRENT BIT 7 = BRIDGE OVERLOAD		
624	MAINTAINED START 0 = MOMENTARY 1 = MAINTAINED		

Parameter Number	Description	Value	PLC Reference
625	TORQUE MODE 0 = ZERO TORQUE COMMAND 1 = VELOCITY REG. OUTPUT 2 = EXTERNAL TORQUE REF 3 = MIN SELECTION OF 1 & 2 4 = MAX SELECTION OF 1 & 2		
626	JOG RAMP ENABLE 0 = NO RAMP USED 1 = RAMP USED		
627	FLUX MODE SELECT BIT 0 = FIELD ECONOMY ENABLE BIT 1 = FIELD WEAKENING ENABLE BIT 2 = EXTERNAL FEED FORWARD BIT 3 = COUNTER EMF SELECTED BIT 4 = CEMF HOLD BIT 5 = CEMF RESET BIT 6 = DISABLE FIELD LOSS DETECTION BIT 7 = NO FLUX COMPENSATION		
628	PROCESS TRIM SELECT 0 = DISABLE PROCESS TRIM 1 = SPEED TRIM 2 = TORQUE TRIM		
629	MOTOR OVERLOAD SELECT 0 = OVERLOAD FUNCTION DISABLED 1 = 60 SEC TO TRIP @ 150% COOLED MTRS 2 = 60 SEC TO TRIP @ 200% COOLED MTRS 3 = 60 SEC TO TRIP @ 150% MTRS 4 = 60 SEC TO TRIP @ 200% MTRS		
630	FAULT REPORT 0 = CP FAULTS 1 = VP FAULTS		
631	FEEDBACK FILTER SELECT 0 = NO FILTER 1 = 35/49 RADIAN FILTER 2 = 20/40 RADIAN FILTER		
632	WARNING SELECT BIT 0 = MOTOR OVERLOAD PENDING BIT 1 = EXCESSIVE ARM VOLTS BIT 2 = BRIDGE OVERLOAD PENDING		
633	PRESET SPEED 1		
634	PRESET SPEED 2		
635	PRESET SPEED 3		
636	PRESET SPEED 4		
637	PRESET SPEED 5		
638	JOG SPEED 1		
639	JOG SPEED 2		
641	MOP ACCEL 1		
642	MOP ACCEL 2		
643	MOP ACCEL 3		
644	MOP ACCEL 4		
645	MOP DECEL 1		
646	MOP DECEL 2		
647	MOP DECEL 3		
648	MOP DECEL 4		
649	MOP MAX SPEED		
650	MOP MIN SPEED		
651	ACCEL TIME		
652	MOTOR OVERLOAD SELECT		

Parameter Number	Description	Value	PLC Reference
653	DESIRED CONTOUR		
657	DROOP PERCENT		
658	DROOP FILTER		
659	KI VELOCITY LOOP		
660	KP VELOCITY LOOP		
661	KF VELOCITY LOOP		
663	FORWARD BRIDGE CURRENT LIMIT		
664	REVERSE BRIDGE CURRENT LIMIT		
665	START TAPER SPEED		
666	END TAPER SPEED		
667	MIN TAPER CURRENT		
668	di/dt LIMIT		
669	SLAVE PERCENT		
672	KI FLUX		
673	KP FLUX		
674	FIELD ECONOMY REFERENCE		
675	FIELD ECONOMY DELAY		
676	FIELD FLUX REFERENCE		
677	FIELD CURRENT AT 0/8 FLUX		
678	FIELD CURRENT AT 1/8 FLUX		
679	FIELD CURRENT AT 2/8 FLUX		
680	FIELD CURRENT AT 3/8 FLUX		
681	FIELD CURRENT AT 4/8 FLUX		
682	FIELD CURRENT AT 5/8 FLUX		
683	FIELD CURRENT AT 6/8 FLUX		
684	FIELD CURRENT AT 7/8 FLUX		
685	FIELD CURRENT AT 1/0 FLUX		

Parameter 50 “Trend 1 Input” to Parameter 104 “Final Vel Ref”
Parameter 51 “Trend 2 Input” to Parameter 106 “Velocity Fdbk”

The sample period for the trend files will be programmed to 10 secs per data point. The thermal time constant of most motors is quite large, the operating parameters will be captured for 16 minutes prior to the occurrence of the fault. The trigger will be programmed to occur when the fault occurs, the fault will be reported in Parameter 101 “Drive Fault” bit 5. All 100 data samples will be taken prior to the trigger. The necessary set-up parameter values for Trend File 1 Are:

Parameter 904 “Trend Logic Val” = 00000000000100000 (bit sel)
Parameter 910 “Tr1 Opnd Param X” = 104 (test operand)
Parameter 911 “Tr1 Opnd Param Y” = 904 (constant operand)
Parameter 912 “Tr1 Operator” = .EQ. (operator for bit 5)
Parameter 913 “Tr1 Sample Rate” = 10 (sample rate in sec)
Parameter 914 “Tr1 Post Samples” = 0 (# samples after trig)
Parameter 915 “Tr1 Mult Trigger” = OFF (single shot)
Parameter 916 “Tr1 Enable” = ON (enable trend)

Table A.D Parameter Values (continued)

Parameter Number	Description	Value	PLC Reference
686	FIELD WEAKEN SPEED		
687	CEMF REG PRELOAD		
698	AUTO TUNE I LIMIT		
699	AUTO TUNE SPEED		
700	VELOCITY DESIRED SPEED		
701	VELOCITY MAX BANDWIDTH		
702	VELOCITY DAMP FACTOR		
703	SYSTEM INERTIA		
704	AT SPEED 1		
705	AT SPEED 2		
706	AT SPEED 3		
707	AT SPEED 4		
708	AT SPEED 5		
709	UP TO SPEED TOLERANCE		
710	ZERO SPEED TOLERANCE		
711	JOG DWELL		
713	PROCESS TRIM FILTER K		
714	PROCESS TRIM PRELOAD		
715	PROCESS TRIM KI GAIN		
716	PROCESS TRIM KP		
717	PROCESS TRIM LO LIM		
718	PROCESS TRIM HI LIM		
719	PROCESS TRIM OUTPUT GAIN		
720	OVERLOAD PEND LEVEL		
721	PROCESS TRIM LOW SUM		
722	PROCESS TRIM HIGH SUM		
724	ABSOLUTE OVERSPEED		
725	EXTERNAL OVERLOAD DELAY		
726	SCR OVERTEMP DELAY		
727	STALL DELAY		
728	AC LINE TOLERANCE DELAY		
729	FIELD FAULT THRESHOLD		
730	FIELD FAILURE DELAY		
731	TACH LOSS CEMF		
732	TACH LOSS VELOCITY		
733	ARMATURE BRIDGE TYPE		
734	K DISCONTINUOUS		
735	KP ARMATURE LOOP		
736	KI ARMATURE LOOP		
737	KP FIELD LOOP		
738	KI FIELD LOOP		
739	K ARM VOLTS		
740	K AC VOLTS		
741	CURRENT LOOP DESIRED BANDWIDTH		
742	CURRENT LOOP MAX BANDWIDTH		
743	CURRENT LOOP DAMP FACTOR		
780	1395 FIRMWARE VERSION		

Table A.E Internal Configuration Parameters

Constant	Internal Parameter	Linked to Fast Sink Parameter	Description
840	10		
841	11		
842	12		
843	13		
844	14		

Table A.F Trend Function Parameters

Parameter Number	Description	Value	PLC Reference
900	Trend Sign Value		
901	Trend Sign Value		
902	Trend Sign Value		
903	Trend Sign Value		
904	Trend Logic Value		
905	Trend Logic Value		
906	Trend Logic Value		
907	Trend Logic Value		
908	Trend Unsign Value		
909	Trend Unsign Value		

Table A.G Trend Buffer #1 Parameters

Description	Parameter Number	Parameter Range	Parameter Value
Trend Buffer #1 is linked to parameter:			
The output of trend buffer #1 is linked to parameter:			
Trend 1 operand parameter X	910	1-947	
Trend 1 operand parameter Y	911	1-947	
Trend 1 operator	912	GT, LT, EQ, AND, NAND, OR, NOR	
Trend 1 sample rate	913	0.0004-30 seconds	
Trend 1 post samples	914	0-99	
Trend 1 multiple trigger	915	OFF, ON	
Trend 1 enable	916	OFF, ON	
Trend 1 output rate	917	0.0004-30 seconds	

Table A.H Trend Buffer #2 Parameters

Description	Parameter Number	Parameter Range	Parameter Value
Trend Buffer #2 is linked to parameter:			
The output of trend buffer #2 is linked to parameter:			
Trend 2 operand parameter X	920	1-947	
Trend 2 operand parameter Y	921	1-947	
Trend 2 operator	922	GT, LT, EQ, AND, NAND, OR, NOR	
Trend 2 sample rate	923	0.0004-30 seconds	
Trend 2 post samples	924	0-99	
Trend 2 multiple trigger	925	OFF, ON	
Trend 2 enable	926	OFF, ON	
Trend 2 output rate	927	0.0004-30 seconds	

Table A.I Trend Buffer #3 Parameters

Description	Parameter Number	Parameter Range	Parameter Value
Trend Buffer #3 is linked to parameter:			
The output of trend buffer #3 is linked to parameter:			
Trend 3 operand parameter X	930	1-947	
Trend 3 operand parameter Y	931	1-947	
Trend 3 operator	932	GT, LT, EQ, AND, NAND, OR, NOR	
Trend 3 sample rate	933	0.0004-30 seconds	
Trend 3 post samples	934	0-99	
Trend 3 multiple trigger	935	OFF, ON	
Trend 3 enable	936	OFF, ON	
Trend 3 output rate	937	0.0004-30 seconds	

Table A.J Trend Buffer #4 Parameters

Description	Parameter Number	Parameter Range	Parameter Value
Trend Buffer #4 is linked to parameter:			
The output of trend buffer #4 is linked to parameter:			
Trend 4 operand parameter X	940	1-947	
Trend 4 operand parameter Y	941	1-947	
Trend 4 operator	942	GT, LT, EQ, AND, NAND, OR, NOR	
Trend 4 sample rate	943	0.0004-30 seconds	
Trend 4 post samples	944	0-99	
Trend 4 multiple trigger	945	OFF, ON	
Trend 4 enable	946	OFF, ON	
Trend 4 output rate	947	0.0004-30 seconds	

Table A.K Node Adapter Parameters

PLC I/O Word	Port/Parameter A/B	Linked to Parameter	Description
Node Adapter Configuration Rack #			
O : OR0			Block Transfer
O : OR1	400/300		
O : OR2	401/301		
O : OR3	402/302		
O : OR4	403/303		
O : OR5	404/304		
O : OR6	405/305		
O : OR7	406/306		
I : OR0			Node Adapter Status
I : OR1	450/350		
I : OR2	451/351		
I : OR3	452/352		
I : OR4	453/353		
I : OR5	454/354		
I : OR6	455/355		
I : OR7	456/356		

Table A.L Discrete Adapter Configuration Parameters

Discrete Adapter I/O	Parameter Port A/B	Port Configuration Parameters A/B			Linked to Parameter	Description
		Parameter	Value	PLC Address		
Digital In #1	400/300	583/533	BIT			
Digital In #2	400/300	584/534	BIT			
Digital In #3	400/300	585/535	BIT			
Digital In #4	400/300	586/536	BIT			
Digital Out #1	450/350	558/508	BIT			
Digital Out #2	450/350	559/509	BIT			
Analog In #1	401/301	550/	SCALE			
		500				
		551/	OFFSET			
		501				
Analog In #2	402/302	552/	SCALE			
		502				
		553/	OFFSET			
		503				
Analog In #3	403/303	554/	SCALE			
		504				
		555/	OFFSET			
		505				
Analog In #4	404/304	556/	SCALE			
		506				
		557/	OFFSET			
		507				
Analog Out #1	451/351	575/	SCALE			
		525				
		576/	OFFSET			
		526				
Analog Out #2	452/352	577/	SCALE			
		527				
		578/	OFFSET			
		528				
Analog Out #3	453/353	579/	SCALE			
		529				
		580/	OFFSET			
		530				
Analog Out #4	454/354	581/	SCALE			
		531				
		582/	OFFSET			
		532				

Table A.M Digital Reference Adapter Configuration Parameters

Digital Ref Adapter I/O	Parameter Port A/B	Port Configuration Parameters A/B			Linked to Parameter	Description
		Parameter	Value	PLC Address		
Digital In #1	400/300	583/	BIT			
	405/305	533				
Digital In #2	400/300	584/	BIT			
	405/305	534				
Digital In #3	400/300	585/	BIT			
	405/305	535				
Digital In #4	400/300	586/	BIT			
	405/305	536				
Digital In #5	400/300	587/	BIT			
	405/305	537				
Digital In #6	400/300	588/	BIT			
	405/305	538				
Digital In #7	400/300	589/	BIT			
	405/305	539				
Digital In #8	400/300	590/	BIT			
	405/305	540				
Digital In #9	400/300	591/	BIT			
	405/305	541				
Digital In #10	400/300	592/	BIT			
	405/305	542				
Digital Out #1	450/350	558/	BIT			
	454/354	508				
Digital Out #2	450/350	559/	BIT			
	454/354	509				
Digital Out #3	450/350	560/	BIT			
	454/354	510				
Digital Out #4	450/350	561/	BIT			
	454/354	511				
Digital Out #5	450/350	562/	BIT			
	454/354	511				
Analog In #1	401/301	550/	ADC SCALE			
		500				
		551	ADC OFFSET			
		501				
		552	AN GAIN			
		502				
		553	AN OFFSET			
503						
Analog In #2	402/302	554/	ADC SCALE			
		504				
		555/	ADC OFFSET			
		505				
		556/	AN GAIN			
		506				
		557/	AN OFFSET			
507						
Analog Out #1	451/351	575/	DAC SCALE			
		525				
		576/	DAC OFFSET			
		526				

Digital Ref Adapter I/O	Parameter Port A/B	Port Configuration Parameters A/B			Linked to Parameter	Description
		Parameter	Value	PLC Address		
Analog Out #2	452/352	577/	DAC SCALE			
		527				
		578/	DAC OFFSET			
		528				
Digital Reference Input		563/	DIG REF PPR			
		513				
		564/	DIG REF SCALE			
		514				
	Whole 403/404	565/	DIG REF OFFSET			
		515				
	Fraction 404/304	566/	DIG REF FILTER			
		516				
		567/	ONE/TWO/QUAD			
		517				
		568/	DIG MUL CONST			
	Firmware	Version	518			
569/			DIG MUL SEL			
519						
		549/				
		599				Read Only Parameter

Notes:

Numerics

24V Internal Unregulated Supply, **3-28**
24V Unregulated Supply, **3-34**

A

Armature Current Control, **3-15**
Armature Pulse/Snubber Board, **3-24**
Armature Pulse/Snubber Circuits, **3-30**
Armature SCR, **3-22, 3-29**
Auto Tuning, **3-34**

B

Bulletin 1300 Programming Terminal, **2-7**

C

Current Processor Fault, **2-22**

E

Electrical Noise Control, **4-8**
Encoder Device Malfunction, **3-9**
ESD (Electrostatic Discharge), **1-2**

F

Fault
 Current Processor, **2-22**
 Handshake, **2-1**
 Internal Memory, **2-1**
 Soft, **2-2**
 Warning, **2-2**
Fault Response Selection, **2-2**
Fault Setup Parameters, **2-4**
Fault Status Indicators, **2-5**
Fault Velocity Processor, **2-12**
Faults
 Hard, **2-1**
Field Current Control, **3-19**
Field Flux Tuning, **5-4**
Field Pulse/Snubber Board, **3-25**
Field Pulse/Snubber Circuits, **3-32**
Field SCR, **3-24**
Field SCR Module, **3-31**

H

Handshake Fault, **2-1**

Hard Faults, **2-1**

I

Internal Memory Fault, **2-1**

L

Link/Configuration Parameter Malfunctions,
3-3
Logic Control Malfunctions, **3-1**
Logic Supply Level, **3-27, 3-33**

M

Magnetics Bracket Assembly, **3-28**
Magnetics/Power Structure, **3-22**
Main Control Board Test Points, **3-16**
Manual Tuning, **5-1**

P

Power Supply, **3-26, 3-33**

S

Soft Faults, **2-2**
System Processor Faults, **2-7**

T

Test Points
 Main Control Board, **3-16, 6-1**
 Power Stage Interface, **6-3**
 Power Supply, **6-4**

Trending, **4-1**

Tuning

 Field Flux, **5-4**
 Manual, **5-1**
 Velocity Loop, **5-3**

V

Velocity Control Malfunctions, **3-3**
Velocity Feedback Device Malfunction, **3-9**
Velocity Loop Tuning, **5-3**
Velocity Processor Fault, **2-12**

W

Warning Faults, **2-2**

Notes:

www.rockwellautomation.com

Power, Control and Information Solutions Headquarters

Americas: Rockwell Automation, 1201 South Second Street, Milwaukee, WI 53204-2496 USA, Tel: (1) 414.382.2000, Fax: (1) 414.382.4444

Europe/Middle East/Africa: Rockwell Automation, Vorstlaan/Boulevard du Souverain 36, 1170 Brussels, Belgium, Tel: (32) 2 663 0600, Fax: (32) 2 663 0640

Asia Pacific: Rockwell Automation, Level 14, Core F, Cyberport 3, 100 Cyberport Road, Hong Kong, Tel: (852) 2887 4788, Fax: (852) 2508 1846

Publication 1395-5.45 – May, 2003
Supersedes July, 1997

P/N 148903 (01)
Copyright © 2003 Rockwell Automation, Inc. All rights reserved. Printed in USA.